

San Francisco Law Library

No. 98854

EXTRACT FROM BY-LAWS

Section 9. No book shall, at any time, be taken from the Library Room to any other place than to some court room of a Court of Record, State or Federal, in the City of San Francisco, or to the Chambers of a Judge of such Court of Record, and then only upon the accountable receipt of some person entitled to the use of the Library. Every such book so taken from the Library, shall be returned on the same day, and in default of such return the party taking the same shall be suspended from all use and privileges of the Library until the return of the book or full compensation is made therefor to the satisfaction of the Trustees.

Sec. 11. No books shall have the leaves folded down, or be marked, dog-eared, or otherwise soiled, defaced or injured. Any party violating this provision, shall be liable to pay a sum not exceeding the value of the book, or to replace the volume by a new one, at the discretion of the Trustees or Executive Committee, and shall be liable to be suspended from all use of the Library till any order of the Trustees or Executive Committee in the premises shall be fully complied with to the satisfaction of such Trustees or Executive Committee.



Digitized by the Internet Archive
in 2010 with funding from
Public.Resource.Org and Law.Gov

Vol 1900

In the United States
Circuit Court of Appeals
For the Ninth Circuit.

WILSON-WESTERN SPORTING GOODS CO.,
a corporation,

Appellant and Cross-Appellee,
vs.

GEORGE E. BARNHART,

Cross-Appellant and Appellee.

Transcript of Record.

Upon Appeal from the District Court of the United States for the
Southern District of California, Central Division.

FILED

APR 4 1900

In the United States
Circuit Court of Appeals
For the Ninth Circuit.

WILSON-WESTERN SPORTING GOODS CO.,
a corporation,

Appellant and Cross-Appellee,

vs.

GEORGE E. BARNHART,

Cross-Appellant and Appellee.

Transcript of Record.

Upon Appeal from the District Court of the United States for the
Southern District of California, Central Division.

INDEX.

[Clerk's Note: When deemed likely to be of an important nature, errors or doubtful matters appearing in the original record are printed literally in italics; and, likewise, cancelled matter appearing in the original record is printed and cancelled herein accordingly. When possible, an omission from the text is indicated by printing in italics the two words between which the omission seems to occur.]

	PAGE
Affidavit of George E. Barnhart on Motion to Refer Cause to Special Master.....	26
Amended Praecipe	184
Answer	15
Assignment of Errors of Defendant.....	170
Assignments of Error of Plaintiff.....	180
Bill of Complaint.....	4
Bill of Particulars.....	13
Bond on Appeal of Defendant.....	175
Citation	3
Clerk's Certificate.....	187
Defendant's Exceptions to the Report of the Special Master	160
Defendant's Motion for Bill of Particulars and Extension of Time for Answer.....	10
Decree, Interlocutory.....	164
Exceptions of Defendant to the Report of the Special Master	160
Exceptions of Plaintiff to Report of the Special Master	162
Findings of Fact and Conclusions of Law, Stipulation Adopting Master's Report as.....	163

ii.

	PAGE
Interlocutory Decree.....	164
Motion for Bill of Particulars and Extension of Time for Answer	10
Motion to Refer Cause to Special Master.....	25
Names and Addresses of Attorneys.....	1
Notice and Motion to Refer Cause to Special Master....	25
Notice of Appeal of Defendant.....	174
Notice of Lodgment of Narrative Statement of Testi- mony	148
Notice of Motion for Bill of Particulars.....	11
Notice of Setting.....	29
Order Allowing Appeal of Defendant.....	173
Order Allowing Cross-Appeal of Plaintiff.....	181
Order Approving Bond on Appeal of Defendant.....	176
Order Approving Stipulation Adopting Master's Re- port as Finding of Fact and Conclusions of Law.....	163
Order Extending Time for Answer.....	12
Order of Reference.....	27
Particulars, Bill of.....	13
Petition for Cross-Appeal of Plaintiff.....	178
Petition of Defendant for Appeal.....	168
Plaintiff's Exceptions to Master's Final Report.....	162
Praecipe, Amended.....	184
Reference, Order of.....	27
Report of Special Master.....	148

	PAGE
Statement of Evidence in Narrative Form.....	30
Stipulation re Statement of Evidence in Narrative Form	147
Testimony on Behalf of Plaintiff:	
Barnhart, George E., direct examination.....	31
Cross-examination	38
Redirect examination.....	47
Cross-examination (further).....	49
Direct examination (rebuttal).....	140
Cross-examination	144
Malley, Jack (rebuttal) direct examination.....	131
Cross-examination	133
Testimony on Behalf of Defendant:	
Doble, William A., direct examination.....	81
Cross-examination	197
Redirect examination (recalled).....	134
Recross-examination	136
Redirect examination.....	139
Flynn, Thomas J., direct examination.....	64
Cross-examination	66
Redirect examination.....	67
Recross-examination	68

Statement of Evidence—Continued	PAGE
Gillette, Horace E., direct examination.....	51
Cross-examination	56
Redirect examination.....	60
Recross-examination	62
Redirect examination.....	63
Direct examination (further).....	78
Cross-examination	78
Redirect examination.....	80
Patterson, J. A., direct examination.....	69
Cross-examination	70
Redirect examination.....	75
Recross-examination	77
Redirect examination.....	77
Recross-examination	77
Stipulation Adopting Master's Report as Findings of Fact and Conclusions of Law.....	163
Stipulation Providing for Filing of Original Exhibits with Clerk of Circuit Court of Appeals.....	183
Stipulation Waving Bond on Cross-Appeal.....	182

INDEX TO EXHIBITS.

	PAGE
Plaintiff's:	
Exhibit No. 1—Patent No. 1,639,547, granted to George E. Barnhart, August 16, 1927.....	30
Exhibit No. 2—Patent No. 1,639,548, granted to George E. Barnhart, August 16, 1927.....	30
Exhibit No. 3—Golf Club Sold by Defendant.....	30
Exhibit No. 4—Notice of Infringement.....	32
Exhibit No. 5—Page from November, 1929 issue of "Golfton"	33
Exhibit No. 6—Page from March, 1930, issue of "Golfton"	33
Exhibit No. 7—(No exhibit numbered 7.)	
Exhibit No. 8—Six Catalogs entitled "The Gate- way to Golf"	36
Exhibit No. 9—Letter dated September 19, 1933, from Lyon & Lyon.....	48
Exhibit No. 10—Letter dated April 26, 1930, Wil- son-Western Sporting Goods Company in re- sponse to Notice of Infringement.....	48
Exhibit No. 11—Certificate of Secretary of State re Defendant Doing Business in California.....	48
Exhibit No. 12—Golf Club, marked "Professional Special 101"	143

Defendant's:	PAGE
Exhibit A—Letter dated January 24, 1934, Mr. Lyon to Mr. Graham.....	37
Exhibit B—Golf Club.....	43
Exhibit C—Advertising Circular of American Fork & Hoe Co.....	51
Exhibit D—Certified Copy of File Wrapper of Patent No. 1,639,547.....	51
Exhibit E—Certified Copy of File Wrapper of Patent No. 1,639,548.....	51
Exhibit F—Catalog	52
Exhibit G—Catalog	53
Exhibit H—J. H. or Jock Hutchinson Club.....	54
Exhibit I—Wilson Company's Club, Model 283.....	55
Exhibit J-1—Patent to Robertson, No. 206,264.....	80
Exhibit J-2—Patent to Kavanaugh, No. 603,694.....	80
Exhibit J-3—Patent to Lord, No. 1,249,127.....	80
Exhibit J-4—Patent to Isham, No. 1,435,851.....	80
Exhibit J-5—Patent to Lagerblade, No. 1,444,842..	80
Exhibit J-6—Patent to Treadway, No. 1,531,632....	80
Exhibit J-7—Patent to Heller, No. 1,551,563.....	80
Exhibit J-8—Reissue Patent to Heller, No. 16,808..	81
Exhibit J-9—Patent to Maas, No. 1,553,867.....	81
Exhibit J-10—Patent to Reach, No. 1,601,770.....	81
Exhibit J-11—Patent to Mattern, No. 1,605,552.....	81
Exhibit J-12—Patent to Pryde, No. 1,615,232.....	81
Exhibit J-13—British Patent to Saunders, No. 3288 of 1913.....	81

INDEX TO BOOK OF EXHIBITS.

PAGES

Plaintiff's Exhibits:

- Exhibit No. 1—Patent No. 1,639,547,
granted August 17, 1927,
to George E. Barnhart..... 1 to 6 incl.
- Exhibit No. 2—Patent No. 1,639,548,
granted August 17, 1927,
to George E. Barnhart..... 7 to 11 incl.
- Exhibit No. 4—Notice of infringement
dated April 19, 1930..... 12
- Exhibit No. 5—Page from November,
1929, issue of "Golfdom" 13
- Exhibit No. 6—Page from March, 1930,
issue of "Golfdom"..... 14
- Exhibit No. 7—Page from May 17, 1930,
edition of "Colliers"..... 15
- Exhibit No. 8B—Page 4 of 1930 catalogue
of Wilson-Western Sport-
ing Goods Co., entitled
"The Gateway to Golf",
one of the catalogues in-
troduced in evidence as
Plaintiff's Exhibit 8..... 16 and 17
- Exhibit No. 8C—Page 5 of 1931 catalogue
of Wilson-Western Sport-
ing Goods Co., entitled
"The Gateway to Golf,"
one of the catalogues in-
troduced in evidence as
Plaintiff's Exhibit 8..... 18 and 19

Exhibit No. 8D—Page 5 of 1932 catalogue of Wilson-Western Sporting Goods Co. entitled “The Gateway to Golf”, one of the catalogues introduced in evidence as Plaintiff’s Exhibit 8.....	20 and 21
Exhibit No. 9—Letter dated September 19, 1933, Lyon & Lyon to Frank L. A. Graham.....	22
Exhibit No. 10—Letter of Wilson-Western Sporting Goods Co., dated April 26, 1930.....	23
Exhibit No. 11—Certificate of Secretary of State	24

Defendant’s Exhibits:

Exhibit A—Letter dated January 24, 1934, Lewis E. Lyon to Frank L. A. Graham	25
Exhibit C—Advertising circular of American Fork & Hoe Co., with illustration entitled “True Temper”	26 and 27
Exhibit F—Page 22 of 1925 catalogue of Wilson-Western Sporting Goods Co., distributed by B. H. Dyas & Co.....	28 and 29
Exhibit J-1—Patent No. 206,264, dated July 23, 1878, to J. A. Robertson	30 to 33 incl.

PAGES

Exhibit J-2—Patent No. 603,694, dated May 10, 1898 to Kavanagh....	34 to 36 incl.
Exhibit J-3—Patent No. 1,249,127, dated Decembed 4, 1917, issued to Lard	37 to 42 incl.
Exhibit J-4—Patent No. 1,435,851, dated November 14, 1922, to Isham	43 to 47 incl.
Exhibit J-5—Patent No. 1,444,842, dated February 13, 1923, to Lager- blade	48 to 51 incl.
Exhibit J-6—Patent No. 1,531,632, dated March 21, 1925, to Treadway	52 to 55 incl.
Exhibit J-7—Patent No. 1,551,563, dated September 1, 1925, to Heller..	56 to 59 incl.
Exhibit J-8—Reissue patent No. 16,808, dated December 6, 1927, to Heller	60 to 63 incl.
Exhibit J-9—Patent No. 1,553,867, dated September 15, 1925, to Maas..	64 to 68 incl.
Exhibit J-10—Patent No. 1,601,770, dated October 5, 1926, to Reach, et al.....	69 to 72 incl.
Exhibit J-11—Patent No. 1,605,552, dated November 2, 1926, to Mattern	73 to 77 incl.
Exhibit J-12—Patent No. 1,615,232, dated January 25, 1927, to Pryde, et al.	78 to 81 incl.
Exhibit J-13—British Patent No. 3288, 1913, to Saunders.....	82 to 89 incl.

Names and Addresses of Attorneys.

For Defendant, Appellant and Cross-Appellee:

LYON & LYON, Esqs.,

LEWIS E. LYON, Esq.,

HENRY S. RICHMOND, Esq.,

National City Bank Building,

Los Angeles, California.

For Plaintiff, Cross-Appellant and Appellee:

FRANK L. A. GRAHAM, Esq.,

Subway Terminal Building,

Los Angeles, California.

CITATION.

UNITED STATES OF AMERICA : ss.
TO GEORGE E. BARNHART,

GREETING:

YOU ARE HEREBY CITED AND ADMONISHED to be and appear at the United States Circuit Court of Appeals for the Ninth Circuit to be held at the City of San Francisco, in the State of California, on the 24th day of November, 1934, pursuant to Notice of Appeal in the Clerk's Office of the District Court of the United States in and for the Southern District of California, in that certain suit in equity wherein you are plaintiff and Wilson-Western Sporting Goods Co., a corporation, is defendant, to show cause, if any there be, why the Interlocutory Decree entered September 24th, 1934, in said cause mentioned should not be corrected and speedy justice should not be done to the parties in that behalf.

WITNESSETH the Honorable Paul J. McCormick, United States District Judge for the Southern District of California, this 24th day of October, A. D., 1934, and of the Independence of the United States the one hundred fifty-ninth.

Paul J. McCormick
United States District Judge for the
Southern District of California.

Due Service of the foregoing Citation is hereby admitted this 23rd day of October, 1934.

Frank L. A. Graham
Attorneys for Plaintiff

[Endorsed]: Filed Oct 24 1934 R. S. Zimmerman.
Clerk By L. Wayne Thomas Deputy Clerk

CITATION.

UNITED STATES OF AMERICA : ss.

To WILSON-WESTERN SPORTING GOODS
CO., (a corporation).

GREETING:

YOU ARE HEREBY CITED AND ADMONISHED to be and appear at the United States Circuit Court of Appeals for the Ninth Circuit to be held at the City of San Francisco, in the State of California, thirty (30) days from and after the date this citation bears date, pursuant to Order Allowing Cross-Appeal in the Clerk's Office of the District Court of the United States in and for the Southern District of California, in that certain suit in equity wherein you are defendant and George E. Barnhart is plaintiff, to show cause, if any there be, why the Interlocutory Decree entered September 24th, 1934, in said cause mentioned should not be corrected and speedy justice should not be done to the parties in that behalf.

WITNESSETH the Honorable Paul J. McCormick, United States District Judge for the Southern District of California, this 24th day of October, A. D., 1934, and of the Independence of the United States the one hundred fifty-ninth.

Paul J. McCormick
United States District Judge for the
Southern District of California.

Due Service of the foregoing Citation is hereby admitted this 24th day of October, 1934.

Lyon & Lyon
Henry S. Richmond
Attorney for Defendant

[Endorsed]: Filed Oct. 24, 1934 R. S. Zimmerman,
Clerk By Edmund L. Smith, Deputy Clerk.

IN THE UNITED STATES DISTRICT COURT
SOUTHERN DISTRICT OF CALIFORNIA
CENTRAL DIVISION

GEORGE E. BARNHART,)	
)	NO. 26-M
Plaintiff,)	IN EQUITY
)	
vs.)	
)	Infringement of
WILSON-WESTERN SPORTING)	Patents Nos.
GOODS CO., a corporation,)	1,639,547 and
)	1,639,548
Defendant.)	

BILL OF COMPLAINT

Comes now GEORGE E. BARNHART, a citizen of the United States and a resident of the City of Pasadena in the State of California, and brings his Bill of Complaint against WILSON-WESTERN SPORTING GOODS CO., and for cause of action alleges:

I.

That plaintiff GEORGE E. BARNHART is a citizen of the United States, residing in the City of Pasadena, County of Los Angeles, State of California.

II.

That defendant WILSON-WESTERN SPORTING GOODS CO. is a corporation organized and existing under and by virtue of the laws of the State of Maine, and has a place of business at Los Angeles in the State of California within the Southern District of California, Central Division thereof.

III.

That the ground upon which this Court's jurisdiction depends is that this is a suit in equity arising under the patent laws of the United States.

IV.

That heretofore, to wit: prior to October 14, 1926, GEORGE E. BARNHART, then of Pasadena, California, was the original, first and sole inventor of a new and useful invention, to wit: a golf club, not known or used by others before his invention or discovery thereof or patented or described in any printed publication in the United States of America or in any foreign country before his invention or discovery thereof, or more than two (2) years prior to his application for Letters Patent therefor in the United States of America, or in public use or on sale in the United States for more than two (2) years prior to such application for Letters Patent therefor, and not abandoned.

That thereupon, to wit: on October 14, 1926, said GEORGE E. BARNHART made application in writing in due form of law to the Commissioner of Patents of the United States of America for Letters Patent for said invention and complied in all respects with the conditions and requisites of the said law.

V.

That after due proceedings had and due examination made by the Commissioner of Patents upon the aforesaid application as to the patentability of such invention, on August 16, 1927, Letters Patent for the United States, numbered 1,639,547, signed, sealed and executed in due form of law, and bearing date the day and year aforesaid, were granted, issued and delivered by the Commis-

sioner of Patents of the United States of America to the said GEORGE E. BARNHART whereby there was granted and secured to plaintiff GEORGE E. BARNHART, his heirs, legal representatives and assigns for the full term of seventeen (17) years from and after said August 16, 1927, the exclusive right and liberty of making, using and vending to others to be used, said invention throughout the United States of America and the territories thereof, all as will more fully and at large appear in and by said original Letters Patent, a duly certified copy of which will be in court produced as may be required.

VI.

That heretofore, to wit: prior to November 23, 1926, GEORGE E. BARNHART, then of Pasadena, California, was the original, first and sole inventor of a new and useful invention, to wit: a golf club, not known or used by others before his invention or discovery thereof or patented or described in any printed publication in the United States of America or in any foreign country before his invention or discovery thereof, or more than two (2) years prior to his application for Letters Patent therefor in the United States of America, or in public use or on sale in the United States for more than two (2) years prior to such application for Letters Patent therefor, and not abandoned.

That thereupon, to wit: on November 23, 1926, said GEORGE E. BARNHART made application in writing in due form of law to the Commissioner of Patents of the United States of America for Letters Patent for said invention and complied in all respects with the conditions and requisites of the said law.

VII.

That after due proceedings had and due examination made by the Commissioner of Patents upon the aforesaid application as to the patentability of such invention, on August 16, 1927, Letters Patent for the United States, numbered 1,639,548, signed, sealed and executed in due form of law, and bearing date the day and year aforesaid, were granted, issued and delivered by the Commissioner of Patents of the United States of America to the said GEORGE E. BARNHART whereby there was granted and secured to plaintiff GEORGE E. BARNHART, his heirs, legal representatives and assigns for the full term of seventeen (17) years from and after said August 16, 1927, the exclusive right and liberty of making, using and vending to others to be used, said invention throughout the United States of America and the territories thereof, all as will more fully and at large appear in and by said original Letters Patent, a duly certified copy of which will be in court produced as may be required.

VIII.

That by virtue of the premises plaintiff became and now is the sole and exclusive owner of the said inventions and Letters Patent Nos. 1,639,547 and 1,639,548, and of all rights in, to and under the same, including all rights of recovery for past infringement thereof.

IX.

That the invention set forth, described and claimed in said Letters Patent Nos. 1,639,547 and 1,639,548 are of great utility and, if plaintiff can receive lawful protection

against infringers, said Letters Patent will be of great value and benefit to him and great profits and advantages will accrue to him therefrom.

X.

Defendant, well knowing the premises and in violation of the rights of the plaintiff, after notice in writing of plaintiff's exclusive rights under said Letters Patent Nos. 1,639,547 and 1,639,548, and of the defendant's infringement thereof, without authority under said Letters Patent or otherwise, and subsequent to the grant of the said respective Letters Patent and prior to the commencement of this suit, and within the past six (6) years, within the Central Division of the Southern District of California, and elsewhere within the United States, has wrongfully, wantonly and continuously infringed said Letters Patent Nos. 1,639,547 and 1,639,548 by making, selling and using, and causing to be made, sold and used, golf clubs embodying and containing the inventions patented in and by said Letters Patent Nos. 1,639,547 and 1,639,548, and is still so doing and is threatening so to do in the immediate future and during the term of the said Letters Patent.

Though requested to desist from said infringement, defendant refuses so to do, whereby plaintiff has been and still is being and will be, so long as such infringement continues, greatly and irreparably damaged and injured and deprived of the gains, profits, benefits and advantages which he would otherwise make and receive under said Letters Patent, and defendant has made and received and is making and receiving by such infringement large and

continuous profits, benefits and advantages which belong to plaintiff, the amount and extent of which plaintiff cannot ascertain except by the accounting herein prayed.

WHEREFORE, and because without adequate remedy except in this court of equity, plaintiff prays an injunction restraining and enjoining the defendant, its officers, agents, servants, employees and attorneys, and those in active concert or participating with them, from making, selling and using, or causing to be made, sold and used, the inventions patented in and by said Letters Patent Nos. 1,639,547 and 1,639,548; that said Letters Patent Nos. 1,639,547 and 1,639,548 may be declared to be valid and plaintiff to be the sole and lawful owner thereof and of all rights in, to and under the same; that this cause be referred to a Master to take and state an accounting of the profits, gains, advantages and damages accruing by reason of the said infringement; that said Master may be given all the powers conferred on Masters by law and the rules in equity; that plaintiff may have judgment for the profits, gains, advantages and damages so found and the costs of this suit, and that plaintiff may have such other and further relief as to this Court may be deemed just and proper.

George E. Barnhart

Plaintiff.

Frank L. A. Graham

Attorney for Plaintiff

[Endorsed]: Filed Jul. 11, 1933. R. S. Zimmermar,
Clerk By Thomas Madden, Deputy Clerk.

[TITLE OF COURT AND CAUSE.]

DEFENDANT'S MOTION FOR BILL OF PARTICULARS AND EXTENSION OF TIME FOR ANSWER

Now comes the defendant, WILSON-WESTERN SPORTING GOODS CO., a corporation of Maine, by its solicitors, and moves this Court for an order :

(1) Directing the plaintiff to serve and file a bill of particulars:

(a) specifying which claim or claims of each of the Letters Patent alleged in the Bill of Complaint to be infringed are charged to be infringed by the defendant;

(b) with respect to each of the patents in suit, identifying by filing of a specimen, by reference to catalogue number and date or by drawing, including a longitudinal section, the golf club or clubs alleged in the Bill of Complaint to be infringed by the defendant.

The ground for Particular (b) above is that, as stated in the attached affidavit of David Levinson, the defendant has within the last six years catalogued thousands of different golf clubs of varying constructions, and the defendant is without knowledge of which of these the plaintiff alleges to infringe said Letters Patent.

WILSON-WESTERN SPORTING GOODS CO.

By Williams, Bradbury, McCaleb & Hinkle

Solicitors

Lyon & Lyon

Frederick S. Lyon

Leonard S. Lyon

Lewis E. Lyon

Attorneys for defendant

[Endorsed]: Filed Aug. 17, 1933. R. S. Zimmerman, Clerk By L. Wayne Thomas, Deputy Clerk.

[TITLE OF COURT AND CAUSE.]

NOTICE OF MOTION

TO Plaintiff, GEORGE E. BARNHART, and to
FRANK L. A. GRAHAM, Esq., his attorney:

You and each of you will please take notice that on Tuesday, September 5, 1933, at the hour of 10:00 o'clock A. M., or as soon thereafter as counsel can be heard, in the court room of the above entitled court in the Post Office and Federal Building, Los Angeles, California, before the Honorable Paul J. McCormick, defendant will bring on for hearing its Motion for a Bill of Particulars.

Lyon & Lyon

Leonard S. Lyon

Lewis E. Lyon

Attorneys for Defendant.

[Endorsed]: Filed Aug. 17, 1933. R. S. Zimmerman,
Clerk By L. Wayne Thomas, Deputy Clerk.

[TITLE OF COURT AND CAUSE.]

ORDER EXTENDING TIME.

Defendant having filed its motion for Bill of Particulars herein, and having noticed its motion for Bill of Particulars for September 5, 1933, and good cause therefor appearing,

IT IS HEREBY ORDERED that the time within which defendant may file its answer or otherwise plead to the Bill of Complaint herein be extended for a period of thirty days from and after the date upon which the Bill of Particulars of plaintiff provided for herein shall have been served and filed, or thirty days from and after the date upon which defendant's motion for Bill of Particulars shall have been denied.

Paul J. McCormick
United States District Judge

Dated: August 17th, 1933.

[Endorsed]: Filed Aug. 17, 1933. R. S. Zimmerman,
Clerk By L. Wayne Thomas, Deputy Clerk.

[TITLE OF COURT AND CAUSE.]

BILL OF PARTICULARS

Now comes plaintiff GEORGE E. BARNHART and for his Bill of Particulars states as follows:

I.

(a) The claims relied on and which plaintiff charges to have been infringed by the defendant are as follows:

Patent No. 1,639,547

Claims No, 11, 12, 13 and 15.

Patent No. 1,639,548

Claim No. 10.

(b) The golf clubs charged to infringe, in so far as plaintiff is informed at this time, are illustrated in catalogs of the defendant hereinafter referred to, wherein those clubs, illustrated on the pages referred to, infringe both the patents in suit:

1930 Edition, "Gateway to Golf," pages 4, 6, 8, 11 and 14;

1931 Edition, "Gateway to Golf," pages 5, 6, 7, 9, 10, 14, 16 and 18;

1932 Edition, "Gateway to Golf," pages 5, 6, 7, 10, 14, 16, 46 and 50. On such last mentioned page those referred to as "Bomber Iron."

1933 Edition, "Gateway to Golf," pages 6, 11, 13, 18, 19, 23, 33, 34, 36, 50 and 53. On such page 53 the club being marked "Bomber Iron."

The above numbered paragraphs correspond in number to the numbered paragraphs of the Motion for Bill of Particulars.

Dated at Los Angeles, California, this 23rd day of September, 1933.

GEORGE E. BARNHART,
By Frank L A Graham
His Attorney.

[Endorsed]: Received copy of the within Bill of Particulars this 25th day of September 1933 Lyon & Lyon Lewis E Lyon Attorneys for Defendant Filed Sep. 25, 1933. R. S. Zimmerman, Clerk By L. Wayne Thomas, Deputy Clerk

[TITLE OF COURT AND CAUSE.]

ANSWER

Now comes the above named defendant, by its attorneys, and for answer to the bill of complaint herein, says:

1. In answer to paragraph I of the bill of complaint, defendant is without knowledge as to any of the allegations thereof, and therefore denies the same.

2. In answer to paragraph II of the bill of complaint, defendant admits that it is a corporation of the State of Maine, and has a place of business at Los Angeles, in the State of California, within the Southern District of California, Central Division thereof.

3. In answer to paragraph III of the bill of complaint, defendant admits that this is a suit in equity charging infringement of United States Letters Patent, but denies that there is any cause for action as therein charged, and therefore denies the jurisdiction of this court.

4. In answer to paragraph IV of the bill of complaint, defendant denies that prior to October 14, 1926, or at any time, George E. Barnhart, then of Pasadena, California, was the original, first, or sole inventor of any new or useful invention, or, to-wit, a golf club, denies that said alleged invention was not known or used by others before his alleged invention or discovery thereof, denies that it was not patented or described in any printed publication in the United States of America, or in any foreign country before his alleged invention or discovery thereof, or more than two years prior to the alleged application for Letters Patent therefor in the United States of America, denies that said alleged invention was not in public use or on sale in the United States for more than two years prior to such application for Letters Patent therefor, and denies that the same had not been abandoned. Defendant

admits, on information and belief, that on or about October 14, 1926, one George E. Barnhart made application in writing to the Commissioner of Patents of the United States of America for Letters Patent, but denies that said application was in due form of law, denies that said application was for any invention, and denies that the said George E. Barnhart complied in all or any respects with the conditions and requisites of the said law.

5. In answer to paragraph V of the bill of complaint, defendant admits that on August 16, 1927, Letters Patent for the United States, numbered 1,639,547, signed, sealed, and executed in due form of law, and bearing date the day and year aforesaid, were granted and delivered by the Commissioner of Patents of the United States of America, to one George E. Barnhart, and that there was thereby purported to be granted and secured to George E. Barnhart, his heirs, legal representatives, and assigns, for the full term of seventeen (17) years from and after said August 16, 1927, the exclusive right and liberty of making, using, and vending to others to be used, said alleged invention throughout the United States of America and the territories thereof, but defendant denies that said Letters Patent were issued after due proceedings had, or after due examination by the Commissioner of Patents of the application therefor, and denies that said Letters Patent are good and valid in law, or that they grant any exclusive right or rights to plaintiff, George E. Barnhart.

6. In answer to paragraph VI of the bill of complaint, defendant denies that prior to November 23, 1926, or at any time, George E. Barnhart, then of Pasadena, California, was the original, first, or sole inventor of any new or useful invention, or, to-wit, a golf club, denies that said alleged invention was not known or used by others before his alleged invention or discovery thereof, denies

that it was not patented or described in any printed publication in the United States of America, or in any foreign country before his alleged invention or discovery thereof, or more than two years prior to the alleged application for Letters Patent therefor in the United States of America, denies that said alleged invention was not in public use or on sale in the United States for more than two years prior to such application for Letters Patent therefor, and denies that the same had not been abandoned. Defendant admits, on information and belief, that on or about November 23, 1926, one George E. Barnhart made application in writing to the Commissioner of Patents of the United States of America for Letters Patent, but denies that said application was in due form of law, denies that said application was for any invention, and denies that the said George E. Barnhart complied in all or any respects with the conditions and requisites of the said law.

7. In answer to paragraph VII of the bill of complaint, defendant admits that on August 16, 1927, Letters Patent for the United States, numbered 1,639,548, signed, sealed, and executed in due form of law, and bearing date the day and year aforesaid, were granted and delivered by the Commissioner of Patents of the United States of America, to one George E. Barnhart, and that there was thereby purported to be granted and secured to George E. Barnhart, his heirs, legal representatives, and assigns, for the full term of seventeen (17) years from and after said August 16, 1927, the exclusive right and liberty of making, using, and vending to others to be used, said alleged invention throughout the United States of America and the territories thereof, but defendant denies that said Letters Patent were issued after due proceedings had, or after due examination by the Commissioner of Patents

of the application therefor, and denies that said Letters Patent are good and valid in law, or that they grant any exclusive right or rights to plaintiff, George E. Barnhart.

8. In answer to paragraph VIII of the bill of complaint, defendant is without knowledge as to the allegations thereof, and therefore denies the same.

9. In answer to paragraph IX of the bill of complaint, defendant denies that any inventions are set forth, described, or claimed in Letters Patent Nos. 1,639,547 and 1,639,548, and denies that the alleged inventions set forth, described, and claimed therein, are of great or any utility; defendant denies that if plaintiff can receive lawful protection against infringers, said Letters Patent will be of great or any value or benefit to him, or that great or any profits or advantages will accrue to him therefrom. Defendant is without knowledge as to whether there are any infringers thereof, but denies that this defendant is infringing either of said Letters Patent.

10. In answer to paragraph X of the bill of complaint, defendant denies that it well knows the premises; defendant denies that it has violated any rights of the plaintiff; defendant denies that it has received notice in writing of plaintiff's alleged exclusive rights under said Letters Patent Nos. 1,639,547 and 1,639,548, or of defendant's alleged infringement thereof, and denies that without authority under said Letters Patent, or otherwise, and subsequent to the grant of said respective Letters Patent, and prior to the commencement of this suit, and within the past six years, or any time, within the Central Division of the Southern District of California, or elsewhere within the United States of America, it has wrongfully, wantonly, continuously, or in any manner infringed said Letters Patent Nos. 1,639,547, or 1,639,548, by mak-

ing, selling, or using, or causing to be made, sold, or used, golf clubs embodying or containing the alleged inventions purporting to be patented in and by said Letters Patent Nos. 1,639,547 or 1,639,548, and denies that it is still infringing or is threatening to infringe in the immediate future, or at any time during the terms of said Letters Patent.

Defendant denies that it has been requested to desist from said alleged infringement, but denies that it refuses so to do and denies that plaintiff has been, still is being, or will be greatly or irreparably damaged or injured or deprived of any gains, profits, benefits, or advantages which he might otherwise or in any manner make or receive under said Letters Patent, or either of them, by reason of any act of this defendant. Defendant denies that it has made or received, or is making or receiving by such alleged infringement, large or continuous or any profits, benefits, or advantages which belong to plaintiff; denies that it has committed any such act of infringement, and denies that plaintiff is entitled to an accounting herein.

11. Defendant denies that plaintiff is entitled to any of the relief prayed for in the bill of complaint.

12. Defendant further denies each and every allegation of the bill of complaint not herein admitted, controverted, or specifically denied.

13. Relative to plaintiff's bill of particulars heretofore filed herein, defendant denies that it in any way infringes claims 11, 12, 13, and 15, or any other claim of patent No. 1,639,547, and denies that it in any way infringes claim No. 10, or any other claim, of patent No. 1,639,548.

14. For a further and separate defense, defendant alleges upon information and belief, that each of the aforesaid claims of the patents specified in said bill of complaint, is invalid, void, and of no effect, for the reason that the applicant therefor surreptitiously and unjustly obtained the patent for that which was in fact invented by another, if any invention be involved therein, who was using reasonable diligence in adapting and perfecting the same.

15. Defendant further alleges, upon information and belief, that each of the aforesaid claims of the patents specified in the bill of complaint, is invalid, void, and of no effect, because for the purpose of deceiving the public, the description and specification filed in the Patent Office by the applicant therefor in each case was made to contain less than the whole truth relative to the said alleged invention or discovery, or more than was necessary to produce the desired effect.

16. Defendant further alleges, upon information and belief, that the aforesaid claims of the alleged Letters Patent charged to be infringed by this defendant, and each of them, are invalid, void, and of no effect for the following reasons:

(a) That the devices described and claimed in each of said claims, respectively, or material and substantial parts thereof, were patented or described in printed publications prior to the alleged invention or discovery thereof, by the applicant therefor, or more than two years prior to the respective applications for Letters Patent therefor, as follows:

BARNHART PATENT NO. 1,639,547(Claims 11, 12, 13, and 15)

United States

<u>Patent Number</u>	<u>Patentee</u>	<u>Date Issued</u>
206,264	Robertson	July 23, 1878
270,460	Mitchell	January 9, 1883
603,394	Kavanaugh	May 10, 1898
887,753	Beck	May 19, 1908
1,232,816	Lard	July 10, 1917
1,435,851	Isham	November 14, 1922
1,444,842	Lagerblade	February 13, 1923
1,531,632	Treadway	March 31, 1925
1,551,563	Heller	September 1, 1925
1,601,770	Reach, et al.	October 5, 1926
1,615,232	Pryde, et al.	January 25, 1927
1,665,811	Hadden	April 10, 1928

(Filing date in Great Britain
August 16, 1926)

British 30,050	Scott	December 31, 1912
----------------	-------	-------------------

BARNHART PATENT NO. 1,639,548(Claim 10)

United States

<u>Patent Number</u>	<u>Patentee</u>	<u>Date Issued</u>
206,264	Robertson	July 23, 1878
1,435,851	Isham	October 14, 1922
1,551,563	Heller	September 1, 1925
1,553,867	Maas	September 15, 1925
1,601,770	Reach, et al.	October 5, 1926
1,605,552	Mattern	November 2, 1926
British 11,893	Cole	May 24, 1902

and also in other patents and printed publications, the names, numbers, dates, and authors of which are not at present known to defendant, but which when ascertained, defendant prays leave to add hereto.

(b) That the applicant for each of said alleged Letters Patent was not the original, and first inventor or discoverer of the thing patented thereby, or of any material and substantial part thereof, but that prior to the alleged invention thereof by said applicant of each of said alleged patents, each was, if invention be involved therein, invented by and/or known to the parties cited below, viz.:

The patentees listed in paragraph (a) hereof, whose respective patents were granted two or more years prior to the respective applications for the alleged Letters Patent herein charged to be infringed, at the addresses given in their respective patents and applications therefor,

and also by others not now known by defendant, but which when ascertained, defendant prays leave to add hereto.

(c) That more than two years prior to the filing of the respective applications for said alleged Letters Patent, the alleged inventions thereof had been in public use and on sale in the United States, by the parties cited below, viz.:

The patentees listed in paragraph (a) hereof, whose respective patents were granted two or more years prior to the respective applications for the alleged Letters Patent herein charged to be infringed, at the addresses given in their respective patents and applications therefor,

and also by others not now known by defendant, but which when ascertained, defendant prays leave to add hereto.

17. Defendant further alleges, upon information and belief, that said Letters Patent, and particularly the claims thereof herein charged to be infringed, and each of them, are ambiguous, indefinite, and do not set forth any invention in such full, clear, concise, and exact terms as to enable persons skilled in the art to make, construct, or use the same.

18. Defendant further alleges, upon information and belief, that said Letters Patent, and particularly the claims thereof herein charged to be infringed, and each of them, are null, void and of no effect, for the reason that they do not set forth a device which can be put into practical or any use.

19. Defendant further alleges, upon information and belief, that said Letters Patent, and particularly the claims thereof herein charged to be infringed, and each of them, are so restricted and limited in scope by the proceedings in the Patent Office prior to the issuance of said Letters Patent; that such claims, and each of them, if valid at all, are not entitled to any construction which will include or cover any device made, sold, or used by this defendant; wherefore defendant denies infringement of any of the claims of said Letters Patent.

20. Defendant further alleges, upon information and belief, that the state of the prior art existing at the time of the said alleged invention set forth in the claims of

each of the Letters Patent charged to be infringed by this defendant, was such that the alleged improvements set forth therein did not involve invention, but represented at most, the exercise of mere mechanical skill.

21. Defendant further alleges, upon information and belief, that the claims of each of the Letters Patent herein charged to be infringed, cover mere aggregations and not new patentable combinations, and are therefore invalid under the law.

Having answered plaintiff's bill of complaint in so far as defendant is advised it is necessary or material to be answered, this defendant prays to be hence dismissed, with its reasonable charges in this behalf most wrongfully sustained.

WILSON-WESTERN SPORTING GOODS CO.

By Williams, Bradbury, McCaleb & Hinkle,
Lyon & Lyon

Solicitors for Defendant.

Albert G. McCaleb
J. David Dickinson
Leonard S. Lyon
Lewis E. Lyon

Counsel for Defendant.

[Endorsed]: Filed Oct 26, 1933. R. S. Zimmerman
Clerk By L. Wayne Thomas, Deputy Clerk.

[TITLE OF COURT AND CAUSE.]

NOTICE AND MOTION

TO WILSON-WESTERN SPORTING GOODS CO., a corporation, defendant herein, and to LYON & LYON, its attorneys:

YOU, AND EACH OF YOU, will please take notice that plaintiff will move the above entitled Court on Monday, the 2nd day of April, 1934, at the courtroom of said Court, at the hour of 10:00 o'clock A. M., or as soon thereafter as counsel can be heard, to refer the above entitled cause to a Special Master to take and hear the evidence offered by the respective parties and to make his conclusions as to the facts in issue and recommend the judgment to be entered therein, subject to full review by the Court.

This motion will be based upon all of the records, pleadings and files of this cause, and on the affidavit of George E. Barnhart, served herewith.

Dated this 28th day of March, 1934.

Frank L. A. Graham

Attorney for Plaintiff.

POINTS AND AUTHORITIES: Equity Rule 59; Neals, Inc. v. McCormick et al., 19 Fed. (2d) 320; Los Angeles Brush Co. v. James, 272 U. S. 701.

[TITLE OF COURT AND CAUSE.]

AFFIDAVIT OF GEORGE E. BARNHART

STATE OF CALIFORNIA)
) ss.
 COUNTY OF LOS ANGELES)

GEORGE E. BARNHART, being first duly sworn, deposes and says that he resides in Pasadena, County of Los Angeles, State of California; that he is the plaintiff in the above entitled cause; that he is not engaged in the manufacture and sale of golf clubs but seeks to derive benefit from his patented inventions by licensing others to use the said inventions; that the defendant herein is one of the largest manufacturers of golf clubs in the United States and is continuing the infringing acts complained of; that until the determination of the present suit, plaintiff is not in a position to enter into negotiations with others for licensing his inventions under the patents in suit and is thereby irreparably damaged unless speedy determination of the present suit can be had.

Affiant is informed and believes that the above entitled suit is at issue and will be called for setting at the calling of the September calendar; that due to the great number of cases filed prior to this suit and the condition of the calendar as now exists that there seems to be no certainty of a trial date during the present year unless this cause is referred to a Special Master for hearing.

George E. Barnhart.

Subscribed and sworn to before me this 28th day of March, 1934.

[Seal]

Drue L. Hoffman

Notary Public in and for the County of Los Angeles,
 State of California

My Commission Expires June 11, 1934

[Endorsed]: Filed Mar. 28, 1934 R. S. Zimmerman,
 Clerk By L. Wayne Thomas, Deputy Clerk

[TITLE OF COURT AND CAUSE.]

ORDER OF REFERENCE

This cause being at issue, and upon motion of counsel for plaintiff that the same be referred to a Special Master to take and hear the evidence offered by the respective parties and to make his conclusions as to the facts in issue and recommend the judgment to be entered therein, subject to full review by the Court, an affidavit in support of such motion having been filed by plaintiff and such motion and such affidavit filed by said plaintiff having been considered; and it appearing that because of the congestion of the Court's calendar there are many other causes entitled to be first heard, including a large number of criminal causes which are entitled to preference over civil matters as to the trial thereof, that the calendar of the Court is already fully set for a period of about six months in advance of this date; and it further appearing that because of the protracted length of patent trials the result has been and is that other civil litigants having causes to be tried have not been accorded a fair proportion of the time of the Court, and it appearing that this condition will continue unless many of the patent cases, including this cause now pending, can be disposed of in the manner herein provided and hence that in order to fairly and within a reasonable time dispose of the business before the Court it is necessary that this order be made;

IT IS THEREFORE ORDERED that this cause be referred to DAVID B. HEAD, ESQUIRE, Special

Master, to take and hear the evidence offered by the respective parties and to make his conclusions as to the facts in issue and recommend the judgment to be entered thereon; the said Special Master DAVID B. HEAD is authorized and empowered to do all things and to make such orders as may be required to accomplish a full hearing on all matters of fact and law in issue in this cause, reserving to the Court the full right and power to review and determine all questions of fact and law upon exceptions to the report of said Special Master by the respective parties, as fully and completely had this reference not been made and as though this cause had been tried before the Court; the objection of counsel for the defendant to the making of this order referring the cause to the Master is hereby noted, and an exception is allowed in favor of the defendant.

Dated this 5th day of April 1934.

Jeremiah Neterer
District Judge.

APPROVED AS TO FORM, AS PROVIDED IN
RULE 44:

Lyon & Lyon
Lewis E. Lyon
Attorneys for Defendant.

[Endorsed]: Filed Apr. 5, 1934, R. S. Zimmerman
Clerk By L. Wayne Thomas, Deputy Clerk.

[TITLE OF COURT AND CAUSE.]

NOTICE OF SETTING

TO WILSON-WESTERN SPORTING GOODS CO., a
corporation, defendant and Lyon & Lyon and Lewis
E. Lyon, its attorneys:

Please take notice that I will call up the above entitled
cause for setting before Hon. David B. Head, Special
Master herein, at his office in the Federal Building, Los
Angeles, California on Monday the 7th day of May, 1934,
at the hour of ten o'clock A.M., in the forenoon.

Dated this 4th day of May 1934.

Frank L. A. Graham

Attorney for Plaintiff.

[Endorsed]: Filed May 4, 1934 R. S. Zimmerman,
Clerk By L. Wayne Thomas, Deputy Clerk

[TITLE OF COURT AND CAUSE.]

STATEMENT OF EVIDENCE IN NARRATIVE
FORM.

This cause was called for trial on May 29, 1934, before Hon. David B. Head as special master, pursuant to the order of reference dated April 5, 1934, and continued to and including June 1, 1934.

APPEARANCES:

For plaintiff: FRANK L. A. GRAHAM, ESQ., of Los Angeles, California;

For defendant: LEWIS E. LYON, ESQ., of LYON & LYON, Los Angeles, California.

An opening statement was made by counsel for plaintiff and by counsel for defendant, during the course of which the following exhibits were offered and received in evidence:

- Plaintiff's Exhibit No. 1—Patent in suit No. 1,639,547,
granted August 16, 1927, to
George E. Barnhart;
(See Book of Exhibits, Ex-
hibit No. 1)
- “ “ “ 2—Patent in suit No. 1,639,548,
granted August 16, 1927, to
George E. Barnhart;
(See Book of Exhibits, Ex-
hibit No. 2)
- “ “ “ 3—Golf club sold by defendant.
(14-16)

(Testimony of George E. Barnhart)

GEORGE E. BARNHART

the plaintiff, called as a witness in his own behalf, being first duly sworn, testified as follows: (17)

DIRECT EXAMINATION

BY MR. GRAHAM

My name is George E. Barnhart and my residence is care of Pasadena Athletic Club, Pasadena, California. I am engaged in the development of my ideas, perfecting inventions. I am the patentee named in the patents in suit and am the sole and exclusive (18) owner of those patents. I have not assigned any interest in the patents in suit. As to what experience I have had in mechanical construction, I was with the Department of Military Aeronautics with the Government, in Dayton, Ohio, during the early war development, and later chief engineer of the Handley-Page production for the Standard Aircraft at Elizabeth, New Jersey; later, experimental engineer with B. F. Goodrich Company, Akron, Ohio; built and produced various types of aeroplanes; built and produced production pontoons for Navy contracts.

As to whether my experience along mechanical lines has been directed to the field of golf, I saw the need of an additional type of tapered tube for golf clubs several years ago. At that time I also saw the need of additional improvements in golf clubs, and experimented at great length with golf shafts and golf clubs. One of the early problems with the metal shaft was adapting the shaft to meet the hosel condition of a wooden shaft hosel of a golf club, having a wooden shaft. Then later they (19) brought out a hosel having a tight wall between the shaft, a tight wall connection between the shaft and the hosel,

(Testimony of George E. Barnhart)

and at that time there was considerable breakage of the shaft joined at the hosel; also there was considerable sting in the shaft itself, transmitted from the club head to the hand.

I caused to be sent to the defendant in this case a notice of infringement of my patents. Being shown a carbon copy of a letter dated April 19, 1930, and directed to Wilson-Western Sporting Goods Company, 2037 Powell Avenue, Chicago, Illinois, signed by myself, that is the letter I referred to as having been sent to the defendant company.

(The notice of infringement last referred to was offered and received in evidence as Plaintiff's Exhibit No. 4.) (See Book of Exhibits, Exhibit No. 4.)

The matter of the defendant infringing my patents (20) came to my notice by a circular advertisement of the Wilson-Western Sporting Goods Company. Being shown what purports to be a page from the issue of Golf-ton, one dated March, 1930, and the other in November, 1929, that is what I referred to.

Q These pages appear to be advertisements, and at the bottom of each page, in both of these documents, appears the name "Wilson-Western Sporting Goods Company, New York, Chicago, Los Angeles and San Francisco." I will ask you whether or not that is an illustration of the defendant's club that came to your attention at that time. (21)

(Objected to on the ground that the question calls for a conclusion of the witness, as to whether it is any illustration of the defendant's club. Objection overruled. Exception allowed.)

(Testimony of George E. Barnhart)

A It is. (22)

I referred to the November, 1929 issue. That is also true of the March, 1930 issue.

(The page from the November, 1929 issue of "Golfton," was offered in evidence as Plaintiff's Exhibit No. 5, and the page from the March, 1930 issue was offered in evidence as Plaintiff's Exhibit No. 6. Objection was made on the ground that the exhibits were not properly proven or identified, and incompetent, irrelevant and immaterial, and publications of some other club not involved in the issues in this case, and no evidence given which connects it up with defendant. Objection overruled and exception taken. Received in evidence as Plaintiff's Exhibits Nos. 5 and 6.) (See Book of Exhibits, Exhibits Nos. 5 and 6.)

My attention being called to a page having at the top "Collier's for May 17, 1930" and at the bottom saying "Wilson Golf Equipment. Wilson-Western Sporting Goods Company. Football, Baseball, Basketball, etc.," that is another one of those advertisements that came to my notice at that time. (23)

MR. LYON: Objected to as incompetent, irrelevant and immaterial.

THE MASTER: Overruled. What was that date?

MR. GRAHAM: This is May 17, 1930. I wish to read in the record this portion appearing in large black type.

MR. LYON: We object to that.

THE MASTER: It speaks for itself.

MR. GRAHAM: I would like to call that to the court's attention, the reading of that.

THE MASTER: I will read it.

MR. GRAHAM: Now, to make this complete, these catalogs that were given to us at our request, in other

(Testimony of George E. Barnhart)

words, when we told the defendant that we would point out the clubs which we claimed to infringe, they handed us these catalogs for 1929 and 1930.

MR. LYON: It is also a fact, Mr. Graham, that I advised you, under date of January 24, 1934, that this defendant had nothing to do with the catalogs of 1929 and 1930; is that not true?

MR. GRAHAM: That is true, but when we were required to give a bill of particulars we asked you for catalogs of your company, of the defendant company, and these were furnished to us.

MR. LYON: I advised you that I made an error in sending you the 1929 and 1930 catalogs, that they were not published or distributed by this company; is that not correct?

MR. GRAHAM: That is correct.

THE MASTER: What is your contention as to the identity of these?

MR. LYON: There was a company here which, for years, was operating in this state under the name of Wilson-Western—I forget the rest of it's name—I believe Sporting Goods Co. That company was dissolved in the latter part of 1930 and withdrew from business in this state. At that time this Maine corporation was formed under the same name, and was at that time authorized to do business in this state.

THE MASTER: What is the relationship between the two companies, the one that was dissolved and the present one?

MR. LYON: No relationship that I know of.

MR. GRAHAM: It is the same name, Your Honor, apparently, and apparently it is the same company; or,

(Testimony of George E. Barnhart)

for some reason, possibly there was a reorganization or something, and they took out the second charter in a different state.

MR. LYON: There is no corporate identity, so far as I am advised, between the two companies.

THE MASTER: Did the second company succeed to the business of the first company?

MR. LYON: No. I believe the business of the first (25) company was entirely taken over by a Delaware corporation, that its entire assets were taken over by that corporation.

MR. GRAHAM: There is no proof of anything of that kind.

THE MASTER: That is a matter of proof, of course.

MR. LYON: It is a matter of proof for the plaintiff to prove what the 1929 and 1930 company did.

MR. GRAHAM: If the defendant says no, they can offer proof to that effect. So far as we know, they are the same company.

MR. LYON: The burden of proof is actually upon you.

MR. GRAHAM: All we have to prove is that they were here, doing business at the time suit was brought.

MR. LYON: We have admitted that, that there was a company here doing business at that time, by that name.

Being shown a catalog of the *Wilson-Western Sporting Goods Company* of 1930, furnished by the defendant, and my attention being called to page 4, that illustration fairly represents the construction of the defendant's club.

(Objected to as incompetent, irrelevant and immaterial, and on the further ground that no foundation has been laid for the use of that catalog; and on the further ground that defendant advised plaintiff's counsel that that is not

(Testimony of George E. Barnhart)
a catalog furnished or distributed by the defendant company.)

THE MASTER: These catalogs were furnished you by the defendant; is that the case? (26)

MR. GRAHAM: That is correct. (27)

THE MASTER: All right. I will receive them in evidence, all of them. You don't need to further identify them. They were received in response to a bill of particulars?

MR. LYON: There was no bill of particulars asked on which these catalogs were furnished. They were furnished to plaintiff's counsel as a convenience to him; and I also advised him about 10 days later that I made an error in giving him those two catalogs, that they were not supplied by this company.

THE MASTER: I will receive them.

MR. LYON: Note an exception to the ruling.

MR. LYON: In that regard, I would like to ask Mr. Graham if he has the original letter that I wrote, under date of January 24, 1934. I think it would be proper to put that in evidence along with these catalogs at this time.

MR. GRAHAM: I have no objection.

(Six catalogs entitled "The Gateway to Golf" received in evidence as Plaintiff's Exhibit No. 8.) (See Book of Exhibits, Exhibit No. 8.)

(No exhibit offered under number 7.)

MR. LYON: I will ask in that connection that this letter may be received.

MR. GRAHAM: That has been stated and admitted. It is merely to the effect that, after having given us those, and after having furnished the bill of particulars, they sent that letter.

(Testimony of George E. Barnhart)

(Letter dated January 24, 1934, from Mr. Lyon to Mr. Graham, received in evidence as Defendant's Exhibit A.)
(See Book of Exhibits, Exhibit A.)

Q. BY MR. GRAHAM: By the way, when did you first visit a store of the defendant company, the Wilson-Western Company, in Los Angeles, as you recall?

(Objected to as calling for a conclusion of the witness. Objection overruled. Exception.)

A. In the early part of 1930.

As to whether I visited that store on numerous occasions since that time, I have visited another one on South Hill Street, 714 South Hill Street, in 1930, and since then they have moved to West Eighth Street in Los Angeles. The same people were in the store on Hill Street and on Eighth Street.

Being handed a club marked Plaintiff's Exhibit 3 and asked where I got that club, this was purchased from the Wilson-Western Sporting Goods Company on West Eighth Street some time last year.

MR. LYON: We have admitted that that is a club of ours. I don't see any necessity of going into that. We have admitted that that is a club of ours, and that it was sold, or an example of those that we sold.

MR. GRAHAM: Will you admit that that club is one that was purchased from your store?

MR. LYON: It apparently is, yes, purchased from our store or from our distribution somewhere.

Witness continuing:

I find a head having a socket in that golf club, Plaintiff's Exhibit 3 and I find a shaft secured at one end within the socket. The portion of the shaft within the outer end

(Testimony of George E. Barnhart)

of the socket is movable relative to the socket. There is a sealing member positioned at the joint between the outer end portion of the socket and the shaft. The portion of the shaft near the outer end of the socket is freely movable within and relative to and about the outer end portion of the socket.

CROSS EXAMINATION

BY MR. LYON:

As to whether I am what might be classified as a professional inventor, I was trained as an engineer and held several engineering positions. As to my occupation at the present (31) time and not about what I was trained as, well, it affects my work at the present time, because that training helps in the development at the present time. My business at the present time is endeavoring to develop ideas and sell them to somebody. As to how long I have been engaged in the occupation of endeavoring (32) to develop ideas and sell them to someone else, I haven't been endeavoring; I have been developing, when ideas come. for the last 25 years, possibly.

As to when I conducted experiments with golf clubs, in 1924, 1925, 1926 and 1927, I believe; in 1928, probably. As to whether there were two forms of golf clubs being used at that time, the steel-shafted club and the wooden-shafted club, the steel shaft was just beginning to come in at that time. I refer to in 1924 and 1925. As to whether it had been put out extensively as early as 1923, to my knowledge, well, I wasn't particularly interested in it at that time.

Q. You don't know, then, whether it actually started (33) to come out in 1924 or not? That is the first time you had observed it; is that correct?

(Testimony of George E. Barnhart)

A. No. For several years they attempted to bring out the steel shaft, in the Professional Golfers' Association; but it couldn't be approved.

I was not a member of that association. As to how I know that it couldn't be approved, well, I have read literature on it, concerning disapproval of the steel shaft, on the fact that they didn't want to place the steel shaft in an approved position.

The steel-shafted clubs that I experimented with between 1924 and 1928 were commercial articles in the sense that the idea was ready to be placed in production, placed in the hands of a company in that business. I believe I did purchase clubs on the open market to conduct these experiments with. I don't recall ever having purchased on the open market steel (34) shafted clubs. I purchased some from golf professionals, or had some given me, possibly. I believe I purchased them from the golf professionals at the golf clubs. As to what golf professionals, I don't just remember the professional that was in charge at the time at the Pasadena Golf Club. I purchased others, however. I purchased some from Wilson, and some from Wilson-Western Sporting Goods Company, and A. G. Spalding. As to whether those were clubs that I conducted these experiments with, some that I used parts of to conduct experiments with. They were not always steel-shafted clubs. Some of them were. As to whether in those steel-shafted clubs that I purchased at that time to conduct those experiments with it is a fact that the shaft was secured to the club head by the end of the shaft being tapered and driven into a tapered socket formed (35) in the hosel and then pinned in position, they had a wood hosel, or a metal hosel, with a wooden adapter, in which

(Testimony of George E. Barnhart)

the shaft was pinned to the hosel, and the adapter and the shaft—the shaft was pinned to the adapter and hosel. As to whether there were not any of the clubs that I purchased in which there was just a tapered shaft driven into a tapered recess formed in the hosel of the club, an all-metal hosel, and an all-metal shaft, I can't just remember. There were some put out by Bristol that were an all-metal hosel in connection with the shaft. There was a tight fit in that club formed between the hosel and the shaft and that shaft was pinned to the hosel. That manner of connection of that shaft, referring to Plaintiff's Exhibit 3, except for perhaps the upper portion of it, was substantially as illustrated by Exhibit 3, up to your fingers. (36)

Q. The only difference, then, between that manner of securing that shaft which you started to compare that with, with the means of securing shaft Exhibit 3 to the head, was in the use of the rubber washer, as shown in Exhibit 3; is that correct?

A. No.

There was no other difference between the point below the washer and the club head of securing the shaft to the head. As to whether the entire difference was above the point of the washer, the hosel was square across, in that taper, when I started experimenting. It was not square in cross-section. You asked if I was starting my experiment prior to this work. Is (37) that your question?

Q. No. I asked you if one of these clubs that you purchased was a club—and I understood your testimony was that, as you recalled, it was a Bristol club in which the end of the shaft, from the point of my finger down to the club head, was secured inside of the socket, in the same manner as this Exhibit 3. Is that correct?

(Testimony of George E. Barnhart)

A. Yes. During that period between 1924 and 1928, but—

Q. Was that Bristol shaft to which you refer an article on the market before you made the alleged inventions of these patents here?

The Master: As I understand the question, Mr. Lyon wants to know whether the shafts that you bought and saw before you did this work were a tight fit such as is shown at the lower end of this.

A. No. My first work started with the wooden adapter between the wall of the ferrule and the hosel and the tube; that was the first. Then this later tight fitting club came out, but the first work—

I am not sure that it would be correct that this later tight fitting club to which I refer came out before the date on which I made my applications for patent, that is, October, 1926, and November, 1926. I wouldn't be sure whether it is or (38) not. The dates are awful close in there, and I was doing quite a bit of work on the tube, so I couldn't be sure.

Q You wouldn't claim, Mr. Barnhart, would you, that any shaft which was connected merely by a tight fit, in that manner, from the lower end of the rubber socket down to the end of the club, and did not have this rubber in position as shown by Exhibit 3, infringed your patent, would you?

MR. GRAHAM: Just a minute, if the court please. Not only is the question indefinite and vague, but it is asking for the question of infringement there. This witness cannot pass on the question whether or not one is infringing the other. As I understand, what he is trying to get at is whether or not there was a club made—

(Testimony of George E. Barnhart)

THE MASTER: This is the patentee that is testifying. However, the question is indefinite, in that it does not take into account the cut away portion that is shown in this Exhibit 3.

MR. LYON: I say below that.

THE MASTER: The better question is this: Did you consider that your patent described and covered a construction where there was a tight fit between the hosel and the tube or the shaft (39) through its entire length.

MR. GRAHAM: In other words, does his patent cover that. That is what he is trying to ask him. We don't claim that it covers that. I will answer that.

THE MASTER: That is the question, isn't it?

MR. GRAHAM: Assuming that that is a tight fit of the shaft in the hosel and has a rivet through it.

Witness continues:

As to whether this club which has been handed to me by Mr. Graham illustrates one of the types of clubs which was on the market at the time I made the invention which I allege is shown in my patents in suit, no. I believe when I made the invention there was just the wooden hosel, wooden adapter in the hosel. (40)

Q And no clubs of the character of this club which Mr. Graham has handed me were on the market at that time, to your knowledge?

A It was in that period, but I couldn't say for sure whether they were on the market or not.

In speaking of this wooden adapter, I refer to a wooden cylinder which was passed into the cavity in the ferrule of the club, and into which cylinder the end of the shaft fitted; it was put in there, a tapered cylinder. That assembly of the tapered cylinder or frustrated cone which

(Testimony of George E. Barnhart)

fitted inside of the socket of the ferrule and surrounded the end of the shaft was secured in position, the entire assembly was secured together by means of a pin passed through a hole, in substantially the position of the hole as illustrated by this club which Mr. Graham handed me.

(The club produced by Plaintiff's counsel was offered and received in evidence as Defendant's Exhibit B.)

As to whether when that assembly was fixed together, that prior assembly, which included the wooden sleeve, it is not a fact that the joint between the upper end of the ferrule of the club and the shaft of the club was wrapped with a wrapping and the wrapping then coated with shellac to form a tight, water-proof joint at that point, that joint could never be made tight; that was one of the problems, because the shellac would break, (41) after it dried it would break, and the club would flex. It is a fact that the joint was wrapped with twine, and that twine was then shellacked in position. It did not, at least at the start, when it was new, form a fluid or waterproofing between the club and the shaft, because you couldn't make the shellac joint tight. That was one of the problems. As to whether it was tight at no time, not even when it was first put on, when it was first put on, with the wet shellac, of course it might have been fluid tight, but when you flexed the club it would immediately break.

As to whether I can fix any more definitely the date when the Bristol club was brought out, that is, when a club was brought onto the market which eliminated this wooden cylinder interposed between the shaft and the socket of the head ferrule, I couldn't be sure. It might have been on the market, because (42) that problem was discussed at various times. It is not very clear in my mind as to

(Testimony of George E. Barnhart)

whether it was on the market at the time I was working on it or subsequent. (44)

Referring to Defendant's Exhibit B, I would consider the passing of a pin through the hole, the ferrule of the club, as that hole is now placed, would be the securing of the shaft of Exhibit B at its end to the ferrule of the club. As to whether what I am considering as the end of the shaft is any portion of the shaft toward the lower tapered section, well, there is a reasonable distance that would be the end there, a small portion there. You couldn't get to the middle and still have it the end. I mean the middle of the entire shaft (45) It would have to be something like three-quarters of the way down the club to be at the end, probably a little more than that. I would not necessarily consider that securing at the end was securing the shaft at any point within the cavity of the ferrule of the club. As to whether I would or would not consider that if I passed a pin through the very upper portion of the ferrule of the head of Exhibit B, and passed that through the club, that I have secured the shaft to the ferrule at the end of the shaft, it would be dependent, of course, on the length of your ferrule. You asked me about Exhibit B and the lengths are there fixed. I can answer the question, whether or not I would be securing the shaft to the head of Exhibit B if I passed a pin through the very upper portion of the ferrule, and through the shaft, in the manner you have indicated within the last quarter of an inch of the end of the ferrule, the upper end of that ferrule. That would be securing it at its end, at the end of the shaft. You (46) are rather stretching it up that way, but it is at the end. As to how far up there is not stretching it, I would say about the position of that

(Testimony of George E. Barnhart)

pin, or possibly beyond. I mean the position of the hole, of the head of Exhibit B. That is approximately a little bit below the center of the length of the shaft which is within that socket. If it was beyond that center of the portion of the shaft within that socket, I would consider that securing the end of the shaft or securing the shaft at its end in the ferrule of the club. You have a tight hosel there, and the hosel is tightly around it, so it would be at its end. Any time that I used a tight hosel, then, relative to the periphery of the shaft, that would be securing the shaft at its end to the club head, providing you made some provision so that the shaft wouldn't pull out again, so that it would stay in tightly with (47) the wall of the shaft; the inner wall of the hosel would be tightly against the shaft. The purpose of these slots in my patent, Exhibit 1, is to permit a weakening of the shaft at its section within the cut out chamber formed in the hosel of the shaft, and that weakening of the shaft by forming those longitudinal or spiral slots, as shown in Exhibit 1 or Exhibit 2, is to permit a flexing of that shaft within the head torsionally and transversely; there is some movement you gain transversely. That is, the purpose (48) of that weakening of the section of the shaft and the cutting out of that chamber or socket, as shown in Figure 3, is to permit the club shaft to bend somewhat in the manner you have sketched it in dotted lines on a copy of my patent; that in combination with torsioning effect. The reason for my cutting out that chamber around the shaft and inside the hosel is to permit the bending of that portion of the shaft within the hosel; that is one object. There is also another figure there which shows a slightly different use of that principle. If you put a pin through

(Testimony of George E. Barnhart)

there, you do not destroy this effect here that you obtain (49) in the slotted part of the member. You would stop your torsion, but you would still get a bending effect across this pin, across this other axis of the pin. You would stop it from any torsion. There would be some flexing. As to whether if this was a tight driven fit at this upper point where the shaft passes into the end of the hosel, and around that pin, you would still obtain that bending effect inside of the hosel, if there was sufficient area in there to stop movement there would be no motion below. That is shown in Figure 4, that type of structure. If you destroyed the fulcrum you wouldn't have any. (50) That is it. The securing of the shaft at its very end, as illustrated in Figure 1, and also in Figure 4 of Exhibit 1, and securing it at its very end, as shown in the figures of Exhibit 2, is what permits this freedom of motion of that weakened section of the shaft within that cut out chamber. As to whether I ever manufactured any club for the market of the character as disclosed in either of my patents in suit, I made them for the purpose of demonstrating the principle only. I made some clubs. I never endeavored to sell any such clubs.

I have endeavored to obtain some manufacturer of golf (51) clubs or golf shafts who would take a license under my patents. As to whether any such party has ever taken any such license, the Wilson-Western Sporting Goods Company have tentatively opened up negotiations. They made the request to supply them with a price in the matter. They did not, however, take a license and no one else has taken any. As to whether I have submitted the matter in the same manner to Spaldings, (52) Spaldings are probably affected quite differently than Wilson-Western.

(Testimony of George E. Barnhart)

I did play golf with some of these clubs that I experimented with, quite extensively. As to what particular club I played with quite extensively, probably the most used club in my bag was the two iron. As to whether that particular club I testified to as a No. 2 iron in my bag had the spiral slot, I had (53) both kinds. I don't believe I have those clubs at the present time. I have had breakage of the shafts. As to whether there was considerable breakage with those shafts and those club heads, in the spiral there was quite a problem in overcoming breakage, in the spiral, and in the longitudinal slot too there was quite a problem in overcoming breakage.

I did not make any investigation at the time I visited a store at 714 South Hill Street, which I stated was the store of the defendant, to determine who was operating that store. As to how I know it was the store of the defendant, I looked it up in the telephone book, for the address. The telephone book says "Wilson-Western Sporting Goods Company." I don't know whether that is the only manner I have of connecting it with the present defendant. I believe that would be one way of connecting it. (54) I don't know who was in charge of that office or store at 714 South Hill Street. It probably was true that it was a man by the name of Shaeffer. I wouldn't be sure of it.

REDIRECT EXAMINATION

BY MR. GRAHAM:

It appears from my cross examination that I said that my experiments with golf clubs extended over a long period. I had reference to experiments on the golf clubs shown in the patents in suit. So far as the dates of the

(Testimony of George E. Barnhart)

alleged inventions of the Barnhart patents in suit are concerned, I rely only on the filing date of the patents. I do not mean to say by that (55) that that was the time I was engaged in finding out or experimenting with the way of fastening the shaft to the head. The action of the golf club in general. I solved the problem with that adapter or flexing of the shaft over the support and pivotal point. As to whether I did anything about the shaft itself, I developed a machine for making the tapered tube, making the shaft. By "tapered tube" I mean for making a golf club or a golf club shaft of seamless tube.

(At this point plaintiff offered in evidence a letter (57) from Lyon & Lyon dated September 19, 1933, accompanying catalogs, in which it is stated: "We are informed that these catalogs were distributed in this territory by the Wilson-Western Sporting Goods Company, defendant." Received in evidence as Plaintiff's Exhibit no. 9. (See Book of Exhibits, Exhibit No. 9.) Also a letter dated April 26, 1930, from Wilson-Western Sporting Goods Company, signed L. B. Icely, President, in response to the notice of infringement. Received in evidence as Plaintiff's Exhibit No. 10. (See Book of Exhibits, Exhibit No. 10.) Plaintiff also offered in evidence a certificate of the Secretary of State referring to the defendant corporation as having complied with the State requirements for doing business in the State of California. Received in evidence as Plaintiff's Exhibit No. 11.) (See Book of Exhibits, Exhibit No. 11.)

(Testimony of George E. Barnhart)

Further

CROSS EXAMINATION

BY MR. LYON

(59)

Q Mr. Barnhart, this morning you referred to the structures which you obtained before making the invention that you allege is shown in the patents in suit and referred to the structure as put out by the American Fork & Hoe Company.

A I don't know. I don't believe I recall any reference to the American Fork & Hoe Company as to my structure.

My remarks regarding the Fork & Hoe Company were regarding the shaft. Concerning the use of a wood adapter between the shaft and the hosel of the defendant, and being handed an advertising circular of the American Fork & Hoe Company and asked to particularly refer to this illustration given here under where it is entitled "True temper," and whether that is the construction I referred to of that adapter as shown there, I don't recall any such construction at the time I was working on it. This is something that apparently is later than my work. I don't recall any structure of that type. Referring particularly (60) to this wood adapter up here which went between the shaft and the club head, that is not what I referred to as a wood adapter this morning. They show a different structure here than what we had. Concerning this structure here, this doesn't show anything up there. This just shows a plug and doesn't show whether this is a hole or what it is there. This might be a solid forging just as it comes from a drop forge plant. The wood adapter that I referred to this morning was not shaped like this wood

(Testimony of George E. Barnhart)

adapter on its exterior. I believe that some of them had a little different taper than that. I wouldn't say they were slightly different in taper but otherwise they were the same.

Q How did they differ besides a slightly different taper? You have drawn on this illustration a dotted line showing a hole through the center of the wood adapter, is that correct, and also reversed taper lines on the end, which is shown cut to a smaller diameter. Is that the only distinction? (61)

This was a straight line down here. These were straight lines instead of curved lines here. This is a curved flare in there. Instead of being flared, it was essentially a straight taper.

(Witness was requested to mark the words "straight taper" where the straight taper was.)

The club head was forged out to receive that wood adapter. It was forged like this. The other parts of the club as shown in that cut were not approximately as they were at that time. There wasn't any of this and there wasn't any of this, that is, there wasn't any of this fibre check ring. As to whether there is a celluloid sleeve illustrated there, it says "alloy steel sleeve in place." I never saw any alloy sleeve. The (62) difference is, then, that the end of the shaft was inserted directly into the end of the wood adapter, and then that wood adapter with the shaft in place was inserted into the opening that I have drawn in the head. Essentially this went right straight through. The sizes are wrong in proportion here. As to whether the entire assembly was then pinned together with a pin that passed through somewhere like

(Testimony of Horace E. Gillette)

where you have drawn the circle on this illustration, sometimes it was pinned in that direction and sometimes in the opposite direction.

(Advertising circular of American Fork & Hoe Co. with illustration entitled "True Temper", offered and received in evidence as Defendant's Exhibit C.) (See Book of Exhibits, Exhibit C.)

(Plaintiff rests.)

DEFENSE

(63)

(Certified copy of the file wrapper of patent in suit No. 1,639,547 offered and received in evidence as Defendant's Exhibit D. (See Book of Exhibits, Exhibit D.) Certified copy of the file wrapper of patent in suit No. 1,639,548 offered and received in evidence as Defendant's Exhibit E.) (See Book of Exhibits, Exhibit E.)

HORACE E. GILLETTE

called as a witness on behalf of defendant, being first duly sworn, testified as follows:

DIRECT EXAMINATION

BY MR. LYON.

My name is Horace E. Gillette. At the present time I am manager of the Wilson-Western Sporting Goods Company, Los Angeles branch. I have occupied that position since November 15, 1931. Prior to that time I was with B. H. Dyas & Company as manager of their sporting goods department. I occupied (64) that position approximately 10 years. At the time I was working for Dyas & Company I was located at Seventh and Olive

(Testimony of Horace E. Gill ette)

Streets. During the time of my employment with Dyas & Company I bought and sold golf clubs. I inspected and studied the catalogs which were offered by the different companies. I generally also ordered the quantity that we needed from year to year; I mean the quantity of catalogs. Being handed a catalog, I have seen this catalog or one like it before. I first saw that catalog about the first of November in 1924.

While I was with Dyas I sold clubs like those illustrated in that catalog. Being handed a club in pieces (65) and asked if I can identify this club, this is the old Wilson-Jock Hutchinson model made by the Wilson Company. I saw the first samples of those the first of October, 1924. I made purchases of those clubs for Dyas & Company. Quite a quantity of those clubs was sold by Dyas & Company. As to when I made those purchases of clubs like the one just handed me, we generally placed the order in November and received shipment some time about the middle of January or first of February of the following year. Those purchases were made while I was manager of the sporting goods department of B. H. Dyas & Company.

(The catalog identified by the witness was offered in (66) evidence as Defendant's Exhibit F, referring particularly to the illustration of the Jock Hutchinson or J. H. clubs, steel-shafted clubs, as contained in that catalog at page 22.)

Catalogs like this were distributed by B. H. Dyas & Company in Los Angeles. They were sent by mail and distributed by hand. As to approximately how many such catalogs were so distributed, we generally handled around

(Testimony of Horace E. Gillette)

1,500. Those catalogs would be distributed approximately from February 15th and over a period of four or five months. I do not know any particular time when this particular catalog was distributed. (67)

MR. GRAHAM: I mean a catalog having the same contents, the same pages and the same illustrations.

A Yes, sir.

Q You are positive of that?

A Yes, sir.

Q How do you recollect that?

A I handled them.

As to whether I just remember from handling them that they had the same pages and the same illustrations, I wouldn't identify every illustration in it but I sold most of that merchandise. This loose part appearing here is a fly sheet that was printed after the catalog was finished. As to whether they used that same catalog over a number of years, every year the illustrations (68) generally changed. This one was put out in 1925 and it is so dated here by the copyrighters. That is the only way I can identify this catalog, by a copyright notice attached to a design on page 2 of the catalog, and also by a knowledge of the merchandise that is listed. I don't know that that copyright notice may refer to a copyright of this trade insignia or designation or symbol.

(The catalog previously offered in evidence as Defendant's Exhibit F was received in evidence over objection by counsel for plaintiff and an exception noted.) (See Book of Exhibits, Exhibit F.)

(Testimony of Horace E. Gillette)

(At this point defendant offered in evidence the sample of the J. H. or Jock Hutchinson club as identified by the witness. Objection was made to its introduction by counsel for plaintiff on the ground that the witness has not testified (69) that he has known that particular club to have been in existence at any particular time, his testimony being that like clubs were in existence at certain times.)

That is not the exact club that was sold. This particular club does not carry the Wilson label on it but the exact and same clubs were sold by the Dyas Company with the Wilson label on them. This exactly illustrates what I sold in every detail, except for the marking on the face of the head.

(The J. H. or Jock Hutchinson club previously offered in evidence was received in evidence as Defendant's Exhibit G and an exception noted for plaintiff.)

On these clubs that I sold while I was with the Dyas Company in 1925, the shafts were pinned in to the hosel of the club head. It was a very tight fit. The shaft section was (70) slightly tapered. In nearly every instance it was a (71) driven fit. By driven fit I mean we would have to take a ball bat to drive the head on. After the head was driven on with the ball bat, then the pin was put through. There was a hole already in it. They were drilled at the factory, in the shaft and the hosel both. There was not any material of any kind put in at the upper end of the hosel of the club head. There was no wrapping or anything else put at that joint in this grade of club. In the higher grade of club there was some wrapping put on it. That was in 1925. It was generally a thread or

(Testimony of Horace E. Gillette)

string. Varnish or shellac was put on that thread or string (72) just to finish it.

Being handed a further model of club, I can identify this club. That is a Wilson Company's club Model No. 283 as now sold by the Wilson Company. That particular sample came from our shelves the best I know. I am familiar with the manner in which the shaft is secured to the head in this club that I have just identified. There is no difference in the manner of securing that shaft to the club head from the one in which the club head is secured to the shaft in the model Exhibit G, this old J. H. Model. The end of the shaft in the Wilson model that you just handed me is tapered. As to whether it is a driven (73) fit, these are not driven in as tight as the others were, the old models, but in some instances you have got to drive them on, that is, drive the heads on. After it is thus positioned with relation to the head, a pin is used to secure the head to the shaft. In the particular model which I have just identified, the pin is positioned about half an inch up from the end of the shaft, from the tapered end, the end that goes into the hosel.

(The Wilson Company's club Model 283 identified by the witness was offered and received in evidence as Defendant's Exhibit H.)

With this club Defendant's Exhibit H and of this same construction, the Wilson Company has some difficulty with shaft breakage. In most cases the shaft breaks about a quarter of an inch below the top of the hosel. By the top of the hosel I mean the very uppermost end of the hosel, not the uppermost (74) end of the undercut portion; the uppermost end of the hosel. That quarter of an

(Testimony of Horace E. Gillette)

inch would be just about down where that shoulder is; that is where it generally breaks.

I am a very poor golf player. I have played golf about 22 years. During those 22 years I have used different types of clubs that have been placed on the market. As to what causes the breaking of the shaft at the point that I have indicated, that is generally where the stress of the shaft comes, at that particular spot.

The shock or vibration which is transmitted to the club head on the impact of the club head with the ball is the type of shock that Defendant's Exhibit H transmitted up the shaft (75) to the hand. In my opinion there is nothing incorporated in this club which would prevent that shock from being transmitted back to the hand. I state that the shock is transmitted from the club head back to the hands because there is a solid piece in here and it is fastened tight to the club head. There can not be any movement of the end of that shaft as it is secured to the Defendant's Exhibit H or as secured in accordance with Plaintiff's Exhibit 3 within the hosel of the club to absorb that shock or any portion of it.

CROSS EXAMINATION

BY MR. GRAHAM.

I first knew of the defendant company in 1925. As (76) to when I first knew of their store in Los Angeles, they never had a real store. They had a warehouse where they distributed clubs. They had a place on Hill Street. That was about 1930, I think, at least as early as 1930. I was never in that store of the Wilson-Western Sporting Goods Company at that time. I did not see it. I knew it was there from correspondence I had with them. I had correspondence from them at that place of business. (77)

(Testimony of Horace E. Gillette)

Defendant's Exhibit H is a club which was placed on the market by the defendant company here in Los Angeles. They have a number of different types of clubs. They are different constructions from that illustrated in Defendant's Exhibit H. The prices of those clubs vary, according to the different clubs. I did not say that in my opinion there is no shock or sting transmitted to the hands of the golfer in using this club. (78) I said there was nothing that would take that shock away from the hands of a golfer.

The club Defendant's Exhibit H that I have produced is known generally as Model 283. As to what the defendant company designates as the no-shock hosel, it is a little piece of rubber up here. That is the way it was advertised, as a no-shock hosel. It is advertised that way and has been since 1930, I think.

My attention being called to the following statement in the 1930 catalog of the Wilson-Western Sporting Goods Company at page 4: "This invention is so ingeniously worked out that it is possible to obtain this freedom from shock and still have the shaft actually anchored to the club head. This feature forestalls any possibility of shock at the time of impact being transmitted from the club head through the shaft." I do not agree with that statement. It is true that the clubs (79) marketed by my company having that gasket or rubber interposed between the hosel and the shaft are known and sold as a no-shock hosel, as a selling argument. The end of the hosel is cut away on the inside. As to whether I know of my own knowledge whether all of the clubs marketed by my company having that rubber in were made as the club Defendant's Exhibit H, in 1931 they did not have that shoulder in there.

(Testimony of Horace E. Gillette)

Q In other words, in 1930 and 1931 they were made as (80) illustrated on page 4 of this 1930 catalog, Plaintiff's Exhibit 6, is that correct?

A They were made this way in 1930 but not in 1931.

My attention being called to page 5 of a 1931 catalog and to the wording: "Note that the lower end of the shaft is secured to the hosel by close frictional contact and the air chamber at the upper end of the hosel permits a slight play.", to me that does not indicate that the club so illustrated was made in the same way as the 1930. I think the statement that it is made with a slight play at the upper end is an advertising man's idea because the club wasn't made that way. None of the clubs marked by my company since 1930 have been constructed like that illustration shown in the 1930 catalog. As to how I know that, well, I have handled them every year. As to whether we ever cut them open to look at them, we take out shafts and replace them every week. It is my testimony that these statements I have read from the catalog and the illustrations are untrue. A good many of those catalogs were sent through the (81) mail.

My attention being called to Defendant's Exhibit H and holes in the hosel, that is, what might be called a single hole extending from one side through to the other, that is to receive a rivet. It would make a difference in the function of the rivet if that hole for the rivet was a half an inch lower than it is here. It would crack the shaft if you put it any lower. I say that because we tried it. The factory tried quite a few of them that way. I know that of my own knowledge. I did not see them try it, but I have seen some clubs made that way and in nearly every instance the shaft cracked at the end because there

(Testimony of Horace E. Gillette)

was nothing to hold it. That position of (82) the rivet cannot be varied either up or down after the factory makes them. I can't answer the question whether or not it would make any difference in the function of the rivet in holding the shaft in the hosel. I don't know. I do not say that I tried to put a hole through that shaft a half an inch lower. We have had some come out a half an inch lower and in nearly every instance the shaft would crack down toward the end due to the drilling. As far as I know that is the only objection to placing the hole in the shaft at a lower point. The function of the rivet in holding the hosel on the shaft is the same whether it was in the identical spot shown in Defendant's Exhibit H or whether it was lower or higher on the shaft. I don't know that this rubber member has any effect on the club except may be to protect that pyrolene collar up there. (83) I am referring to this back portion above the rubber on the shaft. I don't think the portion of the rubber that extends down between the hosel and the shaft protects the pyrolene collar. It is just the upper part that does. I don't think the rubber performs any function that extends down between the shaft and the hosel. We might just as well leave it out of there. Looking in the end of this hosel I see a shoulder there. If we left the rubber out of there, the shaft would bend directly over that edge, without any resistance in the end of the hosel.

Q When you place the rubber inside of that, in other words, interpose the rubber between the hosel and the shaft, you have a yielding member there that is compressed and takes some of the strain off of that during the bending, isn't that correct?

A Very little.

(Testimony of Horace E. Gillette)

Q. But it takes some of the strain off of it?

A I don't know that it does.

Q Well, the shaft certainly doesn't bend as freely with the rubber out as with it in, does it?

A They break just as quick whether it is in or out.

Q Will you answer the question, please?

A Say it again.

MR. LEWIS E. LYON: I think the witness has answered the question and given his reason for it.

THE MASTER: We will have the question read.

(Question read by the reporter.)

A I have no knowledge with which to answer the question.

Q BY MR. GRAHAM: Then, you don't know?

A I don't know.

As to whether the defendant company puts out a club in which the shaft fits tight within the hosel, all of our shafts fit tight within the hosel. I mean without any rubber such as this shown in Plaintiff's Exhibit 3. We put out cheaper clubs just like that. These with the rubber interposed are sold at quite a higher price, at a substantially higher price, several dollars. (85)

REDIRECT EXAMINATION

BY MR. LYON

The only difference between the cheaper club and our higher priced club is not the use of that rubber between the hosel and the shaft. It is a fact that a great deal of the club of the character of Defendant's Exhibit H is a finer piece of workmanship throughout, with a great deal more ornamentation on it, than the cheaper type of club; a different head, a different shaft, different handles, and

(Testimony of Horace E. Gillette)

different features on the handle, such as this flattened portion of the handle. The cheaper (86) club does not have this marking of the metal on the top and does not have the same type of pyrolene sleeve on here. A great many of them are painted shafts. In fact there isn't anything at all in common between the cheaper type of club and the more expensive type. The heads of the higher priced clubs are made of stainless or chromium steel. Real high priced ones are stainless steel and the others are a very high grade of steel with a very good chromium plate.

I have stated that in my opinion this little piece of rubber like incorporated in Defendant's Exhibit H really has no function other than perhaps to protect the pyrolene sleeve. As to what I base that answer on, I can't feel the difference between them made that way and the other way. The shaft would break just as quick with it in or with it out. I have not tested substantially the same club by taking the rubber out and testing it and then putting it back in and testing it, but some people have.

As to whether I as the sales manager of the Los (87) Angeles concern received any complaints with reference to the use of that rubber in our higher priced clubs, we have had a great many of the professionals tell us we were kidding ourselves. Some of them suggested it would be better for us to take that rubber out for no particular reason why except that the customer asking if that is true you have to tell them no if you tell the truth. As to whether it is not a fact that that little piece of rubber deteriorates under the effect of the weather at that point, it will get hard after a while and you have to either take it out or put a new one in, and they do that because of the fact that it deteriorates the appearance of the club. When it gets hard it cracks away.

(Testimony of Horace E. Gillette)

RECROSS EXAMINATION

BY MR. GRAHAM

The Wilson-Western Sporting Goods Company puts out some clubs called "Oggmented". There are two grades of clubs. (88) The difference between those two grades is generally in the finish of the shaft. Some of them have high powered shafts in them and some of them have straight Union shafts in them. You see this is a cheaper grade than the high powered shaft club grade. It is a Union club, referring to Plaintiff's Exhibit 3. That is a Union shaft, made by the Union Hardware & Metal Company. That is a cheaper shaft. We do not have a sample of the high-powered shaft here. There is no difference in the (89) construction of those two clubs. By "construction" I do not include ornamentation. I mean the way they are put together. As to what I mean by ornamentation, this Union shaft here, for instance, has a cellulose covering, and the cheaper grade of club does not have that on it. It is a plain shaft something like that.

Referring to these two Oggmented clubs and as to whether they both have this covering on the shaft, they have got three of them. The high powered shaft is the shaft made by the Croydon people that has a covering like this on it. Then, the cheaper one is just a plain shaft without any covering on it. This is the second one. This is the Union shaft. Two of them have the cover on and the other one is just a bare shaft. The rubber bushing is used in all three classes of Oggmented clubs. (90) I don't know whether it is shown in the catalog or not. I don't know whether it is shown in there. It is not shown in this one. The Oggmented clubs are not shown in this catalog at all. I don't know

(Testimony of Horace E. Gillette)

whether in the higher prices of the Oggmented clubs the shaft is actually brazed to the head. It might be sweated on; I don't know. I know they are all pinned, but I don't know whether it is sweated on there or not. My testimony is that in all of those Oggmented shafts there is a rubber bushing. I am pretty sure of it. (91) That cheaper grade might be made without, but I still think it has. But we have sold so few of them I haven't paid much attention to it. As to whether those that I am referring to as having sold so few of are the ones without the rubber, I say I think it has the rubber but it might not have. If that is correct, the only difference between those two clubs is that one has the rubber and the other hasn't. There is a difference of about \$2.50 in the selling price. That is not the only difference, that one has the rubber in it and the other hasn't; it is a difference in the make of the shaft, a difference in the shaft and a difference in the grips. As to whether I testified that one had the rubber in and the other did not, you asked me if my opinion was that the cheaper grade had that difference because of the fact it had the rubber or didn't, but that is not the only difference in the price (92) of the club.

REDIRECT EXAMINATION

BY MR. LYON

As to whether in the highest priced club which Wilson sells it is not a fact that that has no rubber at all between the hosel and the shaft but that it is soldered or sweated, that is, the shaft is soldered or sweated to the club head, I don't know whether it is sweated on there or not. I know it is forced on tight and pinned but whether it is a sweat process I don't know. This highest priced

(Testimony of Thomas J. Flynn)

club does not include the rubber; it has the rubber hosel on it, or I think it has. I am not sure about that.

THE MASTER: If he isn't sure about it, give the witness an opportunity to refresh his recollection on it.

I will refresh my recollection on that as to the highest priced club which we sell if I have any method of refreshing my recollection and check up on that and be ready to answer that question the next time we meet. (93)

THOMAS J. FLYNN (94)

called as a witness on behalf of the defendant, being first duly sworn, testified as follows:

DIRECT EXAMINATION

BY MR. LYON

My name is Thomas J. Flynn. I am assistant to Mr. Gillette, assistant branch manager. I have occupied that position since the branch was opened on April 1, 1931. My main job, you might say, is to direct the inside workings of the organization. The sales manager, Mr. Gillette, directs the salesmen and I handle or control the ordering of merchandise and the matter of adjustments in regard to defective merchandise, and I handle the correspondence that does not require his attention and supervise the orders and see that the merchandise is shipped promptly and priced correctly. I also have to do quite a bit of the inside selling.

I am familiar with all of the golf clubs sold by the Wilson-Western Sporting Goods Company here, all the different (95) ent models. I take care of replacements and repairs on all of these different models. I am familiar with each of the three different grades of so-called Oggmented clubs. The highest priced Oggmented club is a

(Testimony of Thomas J. Flynn)

stainless steel blade with a high powered shaft, that retails at \$9.50. As to the ratio of sales of these clubs one to the other of these different grades, the best moving grade that we have is the Oggmented chromium plated head that retails for \$8.50, that has a high powered shaft in it, coming in semi-flex and full flex, the flex indicating the degree of stiffness in the shaft. In these high powered shaft clubs the shafts are made by Croydon. In clubs made with those shafts, the shaft is sweated or soldered to the club head and then pinned. As to whether there is or is not such an element or anything comparable with it incorporated in that high powered shaft club, nothing of that type at all. There is nothing in the high powered shaft that is similar in construction (96) to this outside of the fact it has a steel shaft. As to the ratio of the sales of the Wilson clubs of the high powered shaft type to the type of club as illustrated by this defendant's Exhibit H and Plaintiff's Exhibit 3, roughly we sell about three times as many of the high powered shaft as we do of this shaft. That includes the three different types of high powered shaft, the stiff, the semi-flex and the full flex. As to the ratio of sales of the cheaper type of club, which is the club of this shaft type but having no cellophane or cellulose material covering on the shaft, to the high powered club, of the Oggmented club with the plain shaft this year I believe we have five sets, or perhaps it would be one-sixtieth of what we have sold of the high powered. The cheaper grade of club does (97) not have this little piece of ornamental rubber at the joint between the hosel of the club head and the shaft. The only similarity in that club is the design of the head. It has a much cheaper chromium plate and it has an oxydized finish shaft

(Testimony of Thomas J. Flynn)

as distinguished from the chromium plated shaft or a sheet shaft. The grip is the cheapest available and it does not have our reminder or flat spot feature on the grip. It is a club made to sell solely on price. It does not have that rubber bushing.

CROSS EXAMINATION

BY MR. GRAHAM

This Oggmented club that I have been testifying about really first appeared the latter part of last year, when we usually get our new golf club models for the ensuing year. At that time we had samples only. They really didn't have much sale until lately. In other words, it has just gone on the market this year. That high powered Croydon type that (98) I have referred to is not a straight steel shaft. It is a shaft that is constructed in the same design of the original hickory shaft, that is to say, it is large at the top and tapers down to its smallest diameter within three or four inches of where it enters the hosel; and at that point it enlarges until it gets to the hosel and then it tapers off small again to fit into the hosel of the head. In fact, it has quite a bulge right above the hosel. That is not a new feature this year. We had that last year but not in the Oggmented club. We had it in the professional Special.

As to what proportion of our clubs that had the rubber bushing in, prior to the adoption of the Croydon shaft I would say that we sold very close to 50/50 or possibly 60 per cent with the rubber bushing and 40 per cent without. As to whether that is 50 per cent with the rubber bushing as against all other clubs, well, the rubber bushing was in different models, the same as we have different models

(Testimony of Thomas J. Flynn)

without the rubber bushing. As to what clubs were those that were sold without the rubber bushing during 1932, we had the All American iron, the PGL (99) iron, the Capitol, the Model 72 and the Model 71. The construction in the PGL and the Capitol irons was similar to this straight type of shaft, which is Exhibit B. By that I mean there was no collar of any sort at the hosel, and the other grades above those two had a collar similar to this that abutted directly against the hosel, without any rubber insert. As to whether those 50 per cent of the clubs marketed by our company with the rubber in higher priced clubs than these others I have referred to, well, the Capitol and PGL referred to of this type of construction were the cheapest and the other with the straight collar that abutted up against there was more expensive, depending upon the type of blade and the grip and the rest of the make-up of the club, and then the next step to the rubber no-shock would be approximately 50 cents difference. The no-shock that I refer to is the rubber collar that is inserted on the shaft.

REDIRECT EXAMINATION

BY MR. LYON

(100)

The rubber collar that is inserted on the shaft as far as its effect is concerned doesn't have anything to do but it is a very good mental idea for people to think about. I know that to be a fact because I have played golf with clubs that had them in and that don't have them in. As to whether I have anything to do with repairing those clubs which do have the rubber sleeve in them and those which do not, I have frequently put in shafts. However, I pass on all clubs that come in. The difference in the breakage between those clubs that do and those which do

(Testimony of Thomas J. Flynn)

not have the rubber in there is that the ones with the rubber break more frequently, than those without it. There is a difference between these clubs, the grade which has the pyrolene which comes directly to the top of the hosel and does not have the rubber in it, and a club of this type, which accounts for this 50 cent difference in price that I have stated, other than the fact of the use of this rubber. (101) The difference is in the general make-up of the club, and by that I mean the chromium plating is heavier, the grip is better and the grip has a reminder feature or flat spot. Each of those items of difference occasions a difference in the cost of making the club. We put reminder grips only on the more expensive clubs.

RECROSS EXAMINATION

BY MR. GRAHAM

The Wilson-Western Sporting Goods Company's head office is in Chicago. Mr. L. B. Icely is the president of the company. As to whether I know of my own knowledge how long he has held that office, he was formerly president of the Thomas E. Wilson Company. Then, when the Wilson-Western was organized he was made president of that company. I do not know of my own (102) knowledge when the Wilson-Western Company was organized. I wasn't with the company at that time. I know that Mr. Icely is president of the company at the present time and has been for a number of years.

My opinion is that the purpose of putting the rubber bushing in these clubs is for its advertising value.

(Whereupon an adjournment was taken until Thursday May 31, 1934, at 10:00 o'clock A. M.)

(Testimony of J. A. Patterson)

Los Angeles, California, Thursday, May 31, 1934,
10 A.M. (Parties present as before.)

J. A. PATTERSON

called as a witness on behalf of defendant, being first duly sworn, testified as follows: (104)

DIRECT EXAMINATION

BY MR. LYON

My residence is 1758 South Bedford Street, Los Angeles. My occupation is golf professional. I have been a golf professional 16 or 17 years. As to whether I served an apprenticeship before I became a golf professional, I will have to qualify that statement that I am a golf professional somewhat, because I took over a golf shop, going into the golf business at the advice of my physician. I wasn't a so-called professional for a couple of years after I was in the golf business. When (105) I took over this golf shop I had something to do with the repair and making and assembly of golf clubs. I had a club maker who did the repair work, and I have actually done club repair work myself. I would say that I had 12 years active experience in the club making and repairing end. That took place in the first place at the corner of Hollywood and Vermont Avenue, which was a golf shop before I took it over, and then for 10 years and a half at Griffith Park, I was there, and then four years at the Potrero Country Club. I took over this golf shop on Vermont and Hollywood Boulevard during the war, about 1917, '16. During the time from 1916 to date I have been familiar with the different forms of golf clubs which have appeared upon the (106) market. I am familiar

(Testimony of J. A. Patterson)

with the Wilson line of clubs. I am familiar with the Wilson steel-shafted club. I have seen and handled numbers of the Wilson steel-shafted club which has a rubber washer or member interposed between the head and the shaft. I have played golf 15 or 16 years. Being handed a club marked Defendant's Exhibit H, I have played with and handle and sell clubs of that construction, indicating the construction of the hosel and shaft. I have sold clubs of that construction, and have played with them. I have made tests of that club to determine its characteristics. When it first came out it was (107) supposed to be quite a departure from the usual construction. As to what tests I made, I played with the cushion neck in. I disassembled the head and took the cushion neck out, and then played with them. I could not distinguish any difference in the playing of the club with the cushion neck in and without the cushion neck in. I played with the same club with the cushion neck in and without the cushion neck in. I wouldn't state definitely what year I conducted these experiments, these tests, but I believe about 1929. I made these tests to see what the (108) virtue of that so-called cushion neck was. As to what virtue I found that cushion neck to have, it trimmed up the club a little. It did not affect the qualities of the club in playing with it. The tests that I made were not for the purpose of this trial and they were not made at the request of the Wilson Company.

CROSS-EXAMINATION

BY MR. GRAHAM

These tests took place at the Potrero Country Club. I took them out on the practice field and played balls, shot balls on the practice fairway with them. As to whether

(Testimony of J. A. Patterson)

I did that on just this one occasion that I have mentioned, I did it on any club which came out. I never used this particular (109) club at all, Defendant's Exhibit H, or that particular head. It was a club of that construction, with the shoulder, cushion neck in there. I hit balls on the practice fairway with the club before the cushion neck was taken out. I did the same thing with the cushion neck out. I did that several times. As to why I did it several times, if I was satisfied the first time that I did it, there are several different kinds of clubs. (110) There are mashie niblicks that call for a different shot. You play a mashie niblick different than you do a two iron, a mid-iron. If you are playing a mashie niblick shot you are digging into turf, and you are digging into hard ground, sometimes, and it will give you a different result. If there is any vibration, if there is any give to it, you get more on a mashie niblick shot than you will on a mid-iron shot. At that time I was employed at the Potrero Country Club.

Q Will you describe that club? You say it was not just like this. I don't mean to describe the club as far as the character of the head is concerned, but I mean the balance of the club.

A A fitted steel shaft, a fitted head, with a shoulder on it, at the head of the hosel, between the hosel and the ferrule that is on the shaft.

As to what I mean by shoulder, we sometimes call it a bushing. I have reference to this rubber member that is in the club. As to how the inside of the hosel was fashioned, how the shaft was fashioned in the inside of the hosel, it was graduated; it was tapered.

THE MASTER: Look at this other club here.

(Testimony of J. A. Patterson)

MR. GRAHAM: I don't want him to look at that, if the court please. I want this witness to tell what the club was like that he tried out on the fairway, knocking these balls around.

A It was a graduated hosel. Is that what you mean?

Q It isn't what I mean. I want to know what you mean by "graduated hosel."

A I can't explain it any different, unless you want me to draw a picture of it.

THE MASTER: Draw a picture of it.

Q BY MR. GRAHAM: Certainly, draw a picture of it.

A (Referring to drawing): That is a graduated hosel.

Q You mean a tapered hosel?

A Tapered.

Q Tapered from the top to the bottom of the hole?

A Yes.

Q Did the steel shaft fit the hosel from the bottom of the hosel to the top?

A Not all the way.

Q How could you get the rubber in there if it was graduated as you say?

A Because there was a section in here that was not—that was cut back.

Q Had a shoulder in it.

A I don't know what you mean by shoulder.

Q Do you know what is meant by a shoulder on a stem or a shaft or any mechanical structure?

A That isn't a shoulder. That is a depression.

Q What do you have reference to?

A This cutting out in here.

(Testimony of J. A. Patterson)

Q All right. What is at the end of the cut out portion? Isn't that a shoulder?

A Yes, this is a shoulder.

Q Now, did you ever cut one of those clubs like this is cut, Plaintiff's Exhibit No. 3?

A No.

Q You never did?

A No, sir.

Q Are you prepared to swear that in 1929 you tried out a club with rubber in it that had a shoulder in like that?

A I didn't say it had a rubber. It had fibre in it.

Q A hard fibre washer? Is that correct?

A Correct.

Q A fibre washer that didn't have the resiliency or cushioning effect of a rubber washer; is that correct?

A That is correct.

Q And you are not prepared to swear that the club that you tried out at the time was not constructed as shown in that illustration in Plaintiff's Exhibit 5, instead of having a shoulder in it?

A This was the way it was built.

Q Like that shown in Plaintiff's Exhibit 5?

A If this is Exhibit 5, yes.

Q Then it didn't have a shoulder in it; it didn't have the depression you have referred to in your testimony; is that correct?

A The depression comes there. There is a depression, isn't it?

THE MASTER: Yes. Here is your hosel. There was not a shoulder on that?

A No.

(Testimony of J. A. Patterson)

THE MASTER: It is not the same as this?

A No, it isn't cut back.

THE MASTER: Was it like this or like that?

A Like this.

THE MASTER: Like the one in the advertisement there, Exhibit 5?

A Yes.

Being shown a club marked "Reg. No. P-101, Professional Special" and being asked if that is the construction that I referred to, there isn't enough of it; I couldn't tell. I wouldn't express an opinion. I could not tell from looking at that.

I have been in the business of making golf clubs for 15 years. As to whether I made any myself, I never made this. I did make clubs, hickory shaft clubs. I never had anything to do with the manufacture of steel-shafted clubs. (115)

When I had any repair work to be done, if it was a question of a new shaft, I sent it out and had someone else do it. The necessity of having a new shaft was due to breaking. It would usually break right at the head, just about right at the end of the hosel. The Wilson-Western Sporting Goods Company made these clubs that I have testified to having this hard fibre bushing in. I couldn't tell you what they were called. I have heard of a club called the "No shock hosel". It might be the club made by the Wilson-Western; I don't know; I couldn't tell you. As to whether I am familiar with the names that the manufacturers sell their clubs under, there isn't any club sold as the "No shock" at the present time. There was three (116) or four years ago. As to whether I am quite sure that these clubs that I say I tested were

(Testimony of J. A. Patterson)

not clubs that merely had a fibre washer extending around the club and not extending down inside, in other words, a fibre washer, it came down inside; a fibre washer.

As to what I mean by a golf professional, a golf professional is a man who teaches, makes and sells golf clubs and equipment, and repairs them.

REDIRECT EXAMINATION

BY MR. LYON.

As to whether in my business of repairing golf clubs I had any occasion to take apart the clubs like Defendant's Exhibit H, of the exact construction of the hosel and shaft as they (117) are shown in Defendant's Exhibit H, I did not. We did not have the equipment to repair steel-shafted clubs. As to whether I have ever taken the shaft out of a club of the construction of Defendant's Exhibit H for any purpose, taken it out or putting it in, the only time that I would do anything of that kind was when there would be some looseness in there; I might get it out and put a new pin in it. I have done that. As to whether I have played with clubs like Defendant's Exhibit H, and with the same construction, as differentiated from the construction as shown in Plaintiff's Exhibit No. 5, the difference being that in one club there is a slight tapered pocket and in the other a straight pocket, I have played with both kinds.

Q In your opinion, is there any difference in the construction illustrated in Plaintiff's Exhibit 6 and Defendant's Exhibit H, with respect to the manner in which the shaft is secured to the hosel and the head?

MR. GRAHAM: That is objected to as calling for a (118) conclusion of the witness. The clubs speak for

(Testimony of J. A. Patterson)

themselves. If there is any difference in construction it is apparent from looking at the clubs. It does not require any opinion.

THE MASTER: As between these two exhibits?

MR. GRAHAM: Yes.

MR. LYON: In the use of them.

THE MASTER: So far as the construction is concerned, the objection is sustained.

MR. LYON: In the use of those clubs, with respect to the use of them.

THE MASTER: Has he used the different ones?

MR. LYON: Yes. He has testified to that.

A I wouldn't say there was any difference at all.

As to whether the bushing which is shown in Plaintiff's Exhibit 6, or in Plaintiff's Exhibit 5, differs in any way from the bushing as shown in Defendant's Exhibit H, as I have determined the fact from the use of the two types of clubs, the two bushings are not the same. There is no difference that I can see in the two clubs in play. (119)

Q BY MR. LYON: You have testified on cross-examination that, from your experience as a golf professional, the clubs of the type of Exhibit H, or as shown in Plaintiff's Exhibit 5, broke, when they broke, at the end of the hosel. Will you just go into that more in detail and tell just what you meant by the end of the hosel, and just where that breakage occurs.

A Just about where the two—where the ferrule and the hosel—

Q Is that at the rubber washer or above or below the rubber washer, stretching to the end of the hosel?

A Generally a little bit below the end of the hosel.

(Testimony of J. A. Patterson)

Referring to the end of the depression formed on the inside (120) of the club head hosel, I couldn't say where that breakage occurs with reference to the end of that depression in there.

As to whether I have ever made an examination of the broken shafted clubs of this type to determine just where the breakage did occur, well, as I said before, the breakage mostly always, I would say, in 85 per cent of the cases, is immediately below the end of the hosel.

RE CROSS EXAMINATION

BY MR. GRAHAM

Sometimes they break above the end of the hosel, and (121) sometimes right at the end of the hosel.

REDIRECT EXAMINATION

BY MR. LYON

As to whether the breakage that occurs above the end of the hosel is frequent or infrequent in occurrence, there is less breaking than the breaking below the end of the hosel. As to whether in my opinion, when the shaft breaks above the end of the hosel, that shows correct structure of the tube of the shaft or incorrect structure of the tube of the shaft, generally there is a defect in the shaft. That is when it breaks above the end of the hosel.

RE CROSS EXAMINATION

BY MR. GRAHAM

I have found clubs that were bent and not broken. The bend takes place all the way down the shaft, into the head, even, into the hosel. I have found the bend is usually above the end of the hosel. (122)

(Testimony of Horace E. Gillette)

HORACE E. GILLETTE

(Recalled)

FURTHER DIRECT EXAMINATION

BY MR. LYON

Q BY MR. LYON: When you were on the stand, Mr. Gillette, you were asked whether your highest priced club, or the highest priced club that you sell, had a rubber washer between the hosel and the shaft or whether it did not. You were asked to check up on that question and be ready to answer. Have you checked up on that matter?

A Yes. The highest priced club which the Wilson-Western Company sells does not have the rubber between the hosel and the shaft.

Being handed a club, that illustrates the manner of construction of our highest priced club, sold by the Wilson-Western Sporting Goods Company at the present time. As that club is sold, there is no rubber washer interposed between the hosel and the shaft. The shaft is sweated into the hosel and then pinned.

CROSS EXAMINATION

(125)

BY MR. GRAHAM

My attention being called to that shaft and asked whether it is a very unusual and unique structure, calling my particular attention to the bulge in the shaft, that is a new construction that came out about two years ago. Making shafts of that kind adds some to the cost of the shaft. I don't know how much. As to whether it is a much more expensive shaft than the ordinary straight tapered shaft, it is more expensive. I don't know how much more. That is not largely due to the fact that it

(Testimony of Horace E. Gillette)

is for a higher priced club. There are two features that make this the highest priced club. This doesn't happen to be the head that goes on the highest priced club. The head that goes on the highest priced club has the Ogg-Mented feature, which is one of the features which make it higher priced. In other words, the thing that makes this the highest priced club is this particular kind of head and the particular kind of special shaft, over the ordinary, common, straight shaft. (126)

Q Is that one of the cheaper clubs that you referred to?

(Objected to as not cross-examination.)

MR. GRAHAM: It certainly is. He is talking about a different priced club, and I want to find out what they are.

MR. LYON: That was fully covered.

MR. GRAHAM: We didn't have the club here.

THE MASTER: Well, we will allow this as further cross-examination.

A This is the least expensive Ogg-Mented club.

The one between those two is the one with the rubber hosel. This so-called cheaper club has the head on it that you have right there, and that is sold on this shaft.

As to the difference in price of this shaft which has a peculiar bulge right above the hosel being largely due to the fact of the shaft, the difference is between those two. As (127) to the difference between this cheap club that I have referred to and the one that has the rubber washer in it, how this one is different from the other one, well, the other one has the finish on the shaft; the other one has a cellulose product on it as this one is, and it also has a better grade of shaft and your grips are a little

(Testimony of Horace E. Gillette)

different, and there is a certain amount of work in the balancing of them at the factory, and selecting, and so forth, that makes it more expensive. Some of them are covered and some of them are plain.

REDIRECT EXAMINATION

BY MR. LYON

The differences in the price of the Wilson clubs are determined by the construction of the head and the construction of the shaft, and the grip and the finish and the balance. There is a lot in the selection. The heads, although (128) they may be Ogg-Mented heads, used on different clubs are of different finish and different steel and all that, and it is the same with the shaft.

(At this point Defendant offered in evidence a book of patents as Defendant's Exhibit J, including the following patents:

Patent to J. A. Robertson No. 206,264, of July 23, 1878, (marked J-1)

Patent to Kavanaugh No. 603,694 of May 10, 1898, (marked J-2)

Patent to Lord No. 1,249,127 of December 4, 1917, (marked J-3)

Patent to H. S. Isham No. 1,435,851 of November 14, 1922, (marked J-4)

Patent to H. C. Lagerblade No. 1,444,842 of February 13, 1923, (marked J-5)

Patent to T. G. Treadway No. 1,531,632 of March 31, 1925, (marked J-6)

Patent to P. E. Heller No. 1,551,563 of September 1, 1925, (marked J-7)

(Testimony of William A. Doble)

Reissue patent to P. E. Heller No. 16,808 of December 6, 1927, (marked J-8)

Patent to G. H. Maas No. 1,553,867 of September 15, 1925, (marked J-9)

Patent to M. B. Reach et al. No. 1,601,770 of October 5, 1926, (marked J-10)

Patent to G. W. Mattern No. 1,605,552 of November 2, 1926, (marked J-11)

Patent to R. D. Pryde et al. No. 1,615,232 of January 25, 1927, (marked J-12)

British patent No. 3288 of 1913 to S. A. Saunders, (marked J-13.)

(See Books of Exhibits, Exhibit J-1 to J-13 inclusive.)

WILLIAM A. DOBLE, (132)

called as a witness on behalf of defendant, being first duly sworn, testified as follows:

MR. LEWIS E. LYON: Mr. Graham has agreed to stipulate that Mr. Doble is a mechanical expert and a patent expert, but hasn't agreed to stipulate that he knows anything about golf clubs. Is that correct?

MR. GRAHAM: That is correct. I don't think it is necessary for Mr. Doble to put all his qualifications on the record again. He has testified in a number of cases before this court.

DIRECT EXAMINATION

Q. BY MR. LEWIS E. LYON: With the stipulation made, I will ask Mr. Doble to explain the mechanical structures of the two Barnhart patents in suit, beginning first with Exhibit 1, and then taking Exhibit 2.

(Testimony of William A. Doble)

A. To simplify matters, I would point out that in (133) principles the golf clubs of both Plaintiff's Exhibits 1 and 2 are substantially the same, in that their main objective is to provide a torsional resilience in the portion of the shaft or handle that is entered within the hosel of the club, the idea being to secure in a golf club, having a steel tubular handle or shaft, the characteristics secured from a good hickory shaft, wherein there is not only the question of flexibility in the length of the shaft, but also the question of torsional resilience. The shaft is tapered from the grip to its extreme end. In these clubs as disclosed by the teachings of the (134) patent, the extreme terminal end of the shaft is secured by brazing or some equivalent means into a recess which is formed at the base of the cavity of the hosel. Within the hosel there is an enlarged chamber which extends towards the upper end of the hosel to very nearly its upper end. That portion of the shaft within this enlarged chamber is slotted, commencing at a point shortly within the extreme end of the shaft, and the slot extending to approximately the contracted bore of the hosel above the enlarged chamber, thereby weakening, as the patentee says, the shaft, so that it will have three movements; one a torsional resilience, in that the head secured to the extreme end of the shaft can rotate about the shaft in that portion that is slotted, and where it passes through the contracted neck or, as they term it, the fulcrum or pivot points of the hosel. (135) The second motion is a bending or lateral deflection of the portion of the shaft within the hosel that occurs, due to the weakened condition of the shaft by the slots; the third motion is an axial movement in that the shaft is drawn further into

(Testimony of William A. Doble)

the hosel, or extended beyond the hosel. In the first place, the slots are longitudinal, and, as is illustrated in Fig. 1 of the patent, the extreme end of the shaft is brazed within a recess 1 a' formed in the shank of the head, where the base of the hosel is joined thereto, either by welding or some other means. Above this part the bore of the hosel is enlarged by a chamber 2 a' and the longitudinal slots are shown as 3 a'; now, the theory of this patent is that when the club impacts against the ball, a force or resistance is set up which, due to the weakened condition of that portion of the end of the shaft that is located within the enlarged chamber of the hosel, that the shaft will be torsionally resilient and allow the head to twist with respect to the shaft. Further, to absorb shock, and due to the weakened condition of the end portion of the shaft that is within the enlarged chamber, the shaft can be deflected laterally, as there is a free space between the outside diameter of that portion of the shaft and the inside diameter of the chamber, permitting therefore a bending to set up in the weakened portion of the shaft, which would occur when the blow was struck by the club; and so as to take advantage of this yielding or bending (136) action, the upper end of the hosel, as at 2 b is tapered and curved outwardly to form a fulcrum about which the shaft can move. With the longitudinal slots of the first patent, in striking the ball and in the torsional movement or resilience produced in the weakened portion of the shaft, the shaft is drawn inward into the hosel to such a degree as will be produced by the torsional movement set up in the slotted section of the shaft. Therefore, in this club of Plaintiff's Exhibit 1, it necessarily requires, to carry out the teachings and

(Testimony of William A. Doble)

disclosures of the patent, and it is so disclosed in the patent, that the shaft is only secured to the golf head, the club head I mean, at the extreme end of the shaft, where it is inserted into the tapered chamber 1 a' and is secured there by brazing or some similar means. The shaft above this point, in the weakened section, will therefore twist and allow the upper end of the hosel to rotate about and with respect to the shaft, and as the shaft is tapered and as this helical twisting takes place in the weakened section of the shaft, it tends to shorten the shaft and draw it within the upper end of the hosel, that is the portion 2 b; and therefore, as this shaft is tapered, there must be freedom of space between the shaft and the bore of the upper portion of the hosel. In other words, it must be a free, loose fit, or otherwise the shaft could not function as proposed, and the portion 2 b' of the hosel is presumed to provide a fulcrum or pivot (137) around which the shaft, acting as a lever, will turn. Now, in the patent Exhibit 2, it will be observed that substantially the same mode of operation and purposes and objects are set forth. The main difference between the two patents is that in the first patent the slots in that portion of the shaft within the hosel which weaken the shaft, to permit the bending deflection and the torsional resistance, are longitudinal, that is, they run directly in planes of the axis of rotation of the shaft; whereas in the second patent the slots are shown as helical or spirally slotted, as his specifications state, the spiral slots for the same purpose of weakening the shaft at a definite point to permit torsional resilience and bending or deflection of the shaft within the chambered portion of the hosel, necessary to carry out the teachings and mode of

(Testimony of William A. Doble)

operation of a club made in accordance with the patent. The extreme end of the shaft is the only part that is attached to the shank of the head. As stated on page 1 of the patent, commencing line 112 or about 110 "The small end of the shaft is positioned within the ferrule and the extreme end of the reduced portion is secured to the shank end of the head to which the ferrule is connected." In these patents the terminology is somewhat confusing, because they use the term "ferrule" and "socket" as possibly meaning the same thing, though of course the term "ferrule" is not correct, and it would indicate that (138) the intent of the word "ferrule" was to differentiate between the head where the original hosel of the club was removed, and a ferrule of the type disclosed in the patent was substituted by brazing or welding, though the two terms are used in a rather confusing manner.

Q. BY MR. LEWIS E. LYON: The first Barnhart patent shows the intent of Barnhart to take a club with a short hosel, to cut off that hosel and then to put what he terms a long ferrule on the club head, making a reconstruction of the club so as to enable him to get a long enough ferrule to permit the formation of the slots within the end of the club, does it not?

A. That is the purpose.

MR. GRAHAM: Objected to as to Mr. Barnhart's intent.

Q. BY MR. LEWIS E. LYON: As shown by the patent?

A. As shown by the patent and according to the teachings of the patent.

(Testimony of William A. Doble)

THE MASTER: Oh, the question is leading and suggestive. It is not in the proper form. The objection will be sustained.

MR. LEWIS E. LYON: Exception.

Q. What does the Barnhart patent show with reference to—

THE MASTER: What does it already show that you have not previously covered?

MR. LEWIS E. LYON: Well, he has not covered this at all.

THE MASTER: Call his attention to a particular (139) subject matter, then.

MR. LEWIS E. LYON: That is what I endeavored to do.

THE MASTER: I know, but you had a leading statement.

Q. BY MR. LEWIS E. LYON: The Barnhart patent discloses the reconstruction of a club; what does it disclose with reference to this matter, Mr. Doble?

A. It discloses the means of applying the shaft of the Barnhart patent to a regular form of golf club, and, as he states, the shank of the head is cut off; in referring to Fig. 1 of the patent, this is shown as cut off at the point A, which leaves just a short stub end of the shank of the head, and as shown in Fig. 1 the stub end is provided with a double seat—

MR. GRAHAM (interrupting): If the court please, I again object to this testimony. It is all plain there in the patent. This witness can testify that it shows that in one figure, and then if you read the specifications it says it can be made in one part or made in two parts. What has that got to do with the case? We are not

(Testimony of William A. Doble)

interested in whether a head is made in one part or two parts.

THE MASTER: Do you think that is an essential matter?

THE WITNESS: Yes, Your Honor, because it is a fundamental principle on which the club is supposed to operate.

THE MASTER: Do you mean that it is cut in two (140) pieces at point A?

A. To show what point A means as the base of the ferrule.

MR. LYON: And also the fact—

THE MASTER (interrupting): Let's not argue the matter. Of course, if you consider it an essential point, we will go ahead with it, and take your interpretation of it for the present. That is, it is essential to the invention that the ferrule be a separate piece from the head of the club, and that this be joined together at the point A and point B there, whatever it is?

A. No, Your Honor, that is not what I mean. What I am trying to bring out is that when, through this patent, the end of the shaft is referred to, it refers to that extreme end of the shaft which is brazed into the recess in the shank of the club at the base of the hosel, and that is indicated, that position, by the letter A and B.

Q. BY MR. LEWIS E. LYON: Now, Mr. Doble, what does this patent teach with reference to the length of a hosel or ferrule, as compared with the standard construction of the club, in order to obtain the results of Barnhart?

A. It calls for a long hosel, and again in referring to Fig. 1 of the patent, it will be noted, in dotted lines,

(Testimony of William A. Doble)

the standard hosel which is indicated by the letter S. This is an outwardly flared common form of hosel and it is shown as having (141) been cut off, and the long ferrule 2 has been substituted, so as to give the necessary length within the hosel to permit of the slotted part of the shaft to bring about the torsional and deflection of the shaft within the enlarged chamber in the hosel.

Q. BY MR. LEWIS E. LYON: Now, Mr. Doble, the patent also teaches that the ferrule end of the shaft is to be brazed in that position. Does the patent teach any way that the brazing might be performed?

A. No, it does not.

Q. In your opinion, as an expert on construction of mechanical steel parts, could the shaft be brazed in position as illustrated, and still maintain the temper required in such a steel shaft?

A. No. To braze the end of the shaft in the cavity in the base of the hosel or in the top of the short neck, would require first that the device be gotten to such a temperature as would ruin the shaft, because it would draw out all the temper, and there is no practical way in which you could put brazing material in there without it also filling up at least part of the slots, but the brazing method would ruin the shaft, because it would destroy the temper.

Q. Now, in the Barnhart patent, Plaintiff's Exhibit 2, referring particularly to the Figure 6, there is illustrated a rubber device extending over the end of the hosel—

(142)

THE MASTER (interrupting): Where does it describe the brazing of the shaft?

A. If you will look on page 2, your Honor, along about line 6.

(Testimony of William A. Doble)

THE MASTER: I read that. That says the ferrule and the head member, it says. I thought you said the shaft.

A. Yes.

Q. BY MR. LEWIS E. LYON: Referring to the specifications—

THE MASTER (interrupting): Over here, describing the pouring of metal around it, that is about line 79, page 2, it says “Such as by pouring of molten brass 4 around the inner end of the shaft within the inwardly converging recess and through a hole from the outside of the head member.” Was that what you refer to?

A. Yes, your Honor.

THE MASTER: That is not brazing, is it?

A. Yes. In other words, in brazing we use either brass or an alloy of copper and zinc or an alloy of copper and tin, and the melting point of those is well up towards 15 or 16 hundred degrees Fahrenheit.

THE MASTER: I thought brazing was the forming of a bond between the brass or material you are using and the metal with which it comes in contact?

A. Brazing, if I may say, is gluing two pieces of metal together by introducing between them this metal which can (143) melt and become a bonding member between the two.

THE MASTER: I thought it was necessary, in order to obtain the bond it was necessary to at least raise the temperature of the material that you brought the brazing material into contact with.

A. Yes, up above the melting point of the brazing material. You would have to bring it up to that temperature before the brazing material will form a bond.

(Testimony of William A. Doble)

THE MASTER: I didn't understand that being described here. I thought this just described the pouring of metal into a hole.

A. From the standpoint of a mechanic it—

Q. BY MR. LEWIS E. LYON: If you did not raise the temperature of the metal around the hole, could you pour the material in there?

A. No, it would chill, freeze.

THE MASTER: You would have to bring it to a brazing temperature?

A. Yes, your Honor, the whole thing.

Q. BY MR. LYON: Now, referring to the two Barnhart patents, Plaintiff's Exhibits 1 and 2, is there disclosed in either of those patents securing the club shaft to the head at any point other than the extreme end or at the end of the shaft, as the term is used?

A. No, but I would bring attention to Fig. 4 of the first patent where the portion of the shaft which enters the (144) hosel shown as being necked down, having a minimum diameter at the point indicated by the symbol 3 b', and it also shows the brazing of the extreme end of the shaft to the shank of the head, in the cavity indicated by the symbol 4. This filling material 2 a' is referred to as being lead or some similar material. The description is not very definite.

Q. Now, Mr. Doble, in each of the Barnhart patents in suit the hosel of the club head is shown undercut to provide a chamber around the shaft, is it not?

A. With a modification—

Q. (Interrupting): Just answer. Well, all right.

A. With a modification shown in Fig. 5 of the second patent, where the hosel is not provided with a chamber,

(Testimony of William A. Doble)

and the inventor states that that will reduce the resilience or bending of the shaft within the hosel to a certain or limited extent; but, due to the fact that the shaft is provided with the spiral slots and bending action can take place and will take place because, as you tend to bend such a shaft the slots will tend to close in, so that it does not provide as free a bending at the point within the hosel which would be occupied by the enlarged chamber; but it does provide that because of the fact that the shaft is a free fit in the hosel, and as stress would be put upon the shaft to bend it, the helical slots would permit of that bending, because it would tend to provide a freedom (145) at that point.

Q. If dirt or sand found its way into this chamber between the shaft hosel and club, or into the slots 3 a of the structures illustrated in Fig. 5, what effect would that dirt or sand have on the operation of the club as shown in the Barnhart patents?

A. It would prevent the shaft from functioning, as, with foreign material filling up the slots, it would then destroy that flexibility of the portion of the shaft within the enlarged chamber of the hosel.

Q. Would that entering of dirt into the chamber or into the slots 3 a of the structure, illustrated in Figure 5, in any way reduce the torsional longitudinal bending of the shaft as disclosed in the Barnhart patents?

A. Yes, it would defeat that objection, because if that chamber is filled up, then the shaft cannot be deflected, and if the spiral slots are filled, they cannot be as effective. The first movement of the torsional resilience of the shaft would be to increase the width of the slot, and that would allow the foreign matter to go into that

(Testimony of William A. Doble)

enlarged space, and that would prevent the shaft from returning to its original position.

Q. In the mechanical arts, if you want to keep dirt out of something you put a cap on it, don't you?

A. Oh, a cap or a gland or a hood, like they use on automobiles, leather hoods, and then in mechanical arts we use (146) rubber or celluloid; it is one of the oldest shop expedients that I know of. There are two points that I had not finished on that second patent; to complete it, I want to bring it out. In referring to the second patent, it will be noted in Fig. 1 that the hosel tapers off towards its upper end, and is very thin, the purpose, as stated by the inventor being to make the upper end of the hosel thin so that it would deflect or bend with the shaft if the shaft bent more than the free space permitted between the upper and contacted end of the hosel and the shaft. This of course is very ancient practice, as shown by the prior art. And in Fig. 6 there is shown a rubber sleeve surrounding the upper end of the hosel and the shaft at about where it enters the bore of the hosel, and the purpose of that is to keep out sand and mud and water. That is also a very old expedient and is shown in the prior art.

Q. Where, in the disclosures of Plaintiff's (147) Exhibits 1 and 2, Mr. Doble, do you find anything mentioned with reference to the so-called no-shock feature which has been talked about here?

THE MASTER: Don't you know without looking, Mr. Doble?

A. I just wanted to be sure. There is nothing about no-shock or shock in it.

(Testimony of William A. Doble)

Q. BY MR. LEWIS E. LYON: There is nothing about dampening the shock in the disclosures of either of these patents either, is there?

A. No. It is all limited to the torsional and longitudinal resilience in a concentrated portion of the length of the shaft, and there are no cushioning means of any kind, metal to metal contact.

Q. It is true, is it not, Mr. Doble, that the teaching of the Barnhart patents, Plaintiff's Exhibits 1 and 2, is to obtain a freedom of movement of the portion of the shaft which is positioned within the hosel of the club head?

MR. GRAHAM: That is objected to as leading and (148) calling for a conclusion.

THE MASTER: In effect it has already been answered. Objection sustained.

Q. BY MR. LEWIS E. LYON: Mr. Doble, considering Plaintiff's Exhibit 3 and Defendant's Exhibit H, will you state whether there is such a connection there as to obtain freedom of movement of the end of the shaft within the hosel of the club head?

A. No. The connection there is absolutely rigid. There is no relative movement between the shaft and the hosel, that is, it is as rigid as a mechanical joint can be made, that is, in mechanics we can't make a more rigid joint than the tapered fit driven in solid.

Q. Mr. Doble, mechanically what is the effect of weakening the section of the shaft within the hosel in the manner as disclosed in the Barnhart patents Plaintiff's Exhibits 1 and 2, with reference to the club shaft breakage?

(Testimony of William A. Doble)

A. The effect in the construction as shown in those two patents would be to produce a local weakened section, which violates the very fundamentals of mechanics, and it would cause the stresses to concentrate at that point, which would produce fracture. In other words, in mechanics we avoid concentrating stresses of that kind, but produce the same over a greater length.

Q. Now, considering the structures of the defendant's clubs illustrated by Plaintiff's Exhibit 3 and Defendant's (149) Exhibit H, will you point out where, in your opinion, there is found any similarity between the construction of these clubs and the construction of the clubs as disclosed by the two Barnhart patents, Plaintiff's Exhibits 1 and 2?

A. Other than the fact that they are golf clubs and have a head and a handle, then that is the end of the similarity. The mode of operation, construction, results obtained and objects are fundamentally different.

Q. In Plaintiff's Exhibit 3 and Defendant's Exhibit H do you find the shaft secured to the hosel of the club head at the end of the shaft?

A. No, I do not. No, it is not so secured.

MR. GRAHAM: Just a minute.

THE MASTER: What is that?

MR. GRAHAM: Go ahead. He has answered now.

Q. BY MR. LEWIS E. LYON: Referring now, Mr. Doble to the prior art patents Exhibits J-1 to J-13, inclusive, will you briefly describe the structure as disclosed by those prior art patents and compare the structures as disclosed by any prior art patents with disclosures made in the Barnhart patents Plaintiff's Exhibits 1 and 2, and with the defendant's structure of golf clubs, illus-

(Testimony of William A. Doble)

trated by Plaintiff's Exhibit 3, and Defendant's Exhibit H?

A. The Robertson patent, Defendant's Exhibit J-1, discloses the end of a fishing rod or fishing pole, in which the socket forming the outer member, which is letter d is (150) provided with an inner bore of enlarged diameter, and, as the patent states, elliptical in shape, that means elliptical in its length. Within that bore or the socket is a flexible shaft a, secured at one end e to the end of the socket; the rod a, therefore, or shaft can deflect or bend within the length of the socket b, the same as would occur with the shaft in the Barnhart patents where the shaft passes through an enlarged chamber in the socket or hosel. At the top end of the socket, as it has an India rubber or other packing g may be employed at the joint to insure the desired result and prevent water from gaining access to the interior of the handle. So that as far back as 1878 it was a common expedient to use a rubber bushing to exclude water and foreign matter; it was a common expedient to have a socket with an enlarged bore to permit of the deflection of the shaft within the bore, and thereby secure greater elasticity or resilience in the connection between the shaft and the socket. The Kavanaugh patent, Defendant's Exhibit J-2, shows a flexible handle for use with a broom, pitchfork, spade, shovel etc., whereby a flexible connection is provided, this flexible connection consisting of an outwardly flared socket, the handle or shaft pivoted at the lower portion of the socket and a resilient means in the form of two spiral springs interposed between the outer flaring end of the socket and the pole or shaft, to relieve shock and, as the patent says, "This (151) arrangement in-

(Testimony of William A. Doble)

creases the flexibility of the broom so as to accomplish the work in a more satisfactory manner and with less fatigue to the operator than would be the case where the broom is stiff or rigid with the handle, as is the case with the common form now in use.” This patent was applied for in 1897 and shows the fundamental principle of the yielding connection between the head of the device and shaft, for removing shock and making it easier to manipulate, easier on the operator. The patent to Lard, Defendant’s Exhibit J-3, application filed April 3, 1917, discloses a golf club, and it will be noted that there is a flexible sealing member about the juncture of the shaft with the hosel; the hosel being in the form of a tube, and over the extreme end of the tube the leather washers are positioned and cemented, and the leather washers are tapered down so as to make a fine or a thin section merging into the handle, so as to allow for flexing of the handle, distributed over that section or portion of the shaft, and the leather washers are flexible, and the junction between the leather washers to the hosel and the shaft, is a flexible connection which would exclude water from entering into the hosel, as stated in the specifications, page 2, lines 83 to 99.

“A neck constructed by the use of washers or the like absorbs, (152) to a certain extent, or degree, any tendency for the shaft to break at its point of entrance into the tubular socket member. Furthermore, such washers tend in a great measure, to prevent moisture from getting into and around the neck.”

Q. Around the socket, isn’t it?

A. Around the socket.

(Testimony of William A. Doble)

"When rubbed down and shellacked the leather washers become (153) substantially waterproof, and in fact they may be waterproof before being positioned. In positioning the washers, they will preferably be treated with some suitable cementitious material to cause the adherence of the lowermost washer to the adjacent portion of the club, and likewise of the washers to each other and to the shaft." Thereby providing a flexible sealing member positioned at the joint between the outer end portion of the socket and the shaft, and also providing a resilient cushion at the juncture of the shaft with the hosel.

MR. GRAHAM: Are you reading from the patent?

MR. LEWIS E. LYON: He ended the quote back there.

A. I quoted from the patent, and then stopped the quotation.

The patent to Isham, Defendant's Exhibit J-4, application filed April 14, 1920, discloses a hammer mounted on a shaft, with a flexible resilient bushing made of rubber fitted into the eye of the hammer, and between the hammer and the shaft. The construction of the bushing is shown in Fig. 1, and it will be observed that the shape of the shaft or handle at about the middle of its portion that extends into the socket or eye of the hammer is of smaller diameter, quite similar, and exactly similar in principle, to Fig. 4 of the first Barnhart patent: and, due to that contraction or necking in, it retains the shaft in the hammer, and, owing to the difference in (154) curvature between the inside of the socket and the outside of the handle, the thickness of this resilient rubber bushing is thicker at each end, so as to provide an extra cushioning effect, to allow, as the patentee states, page 2, commencing with line 99:

(Testimony of William A. Doble)

“The masses of the elastic cushion which are disposed in the ends of the eye, are larger than the intervening connecting mass of said cushion, and these larger masses admit of considerable amplitude in the oscillations of the handle relative to the head of the implement. Shocks transmitted from the head to the handle are therefore reduced to a minimum, the force of the blow being dissipated or absorbed by various parts of the thimble cushion.”

And on page 3, commencing with line 5:

“A hammer *of* other implement equipped with my invention—rubber-set—protects the hand, wrist and arm muscles from shock of impact and vibration, prevents the head of the implement from chipping, and enables the operator to maximize the force of a blow, thus saving the strength and labor and avoiding much of the usual fatigue incident to work with a hammer *of* a similar implement.”

This device is not limited in the specification to the use in hammers, and therefore we have in the Isham device an impact tool provided with a head and a shaft, an elastic (155) medium in the form of a bushing inserted between the shaft and the socket of the device, the shaft necked in or reduced in its sectional area within the socket, so that the material disposed between the shaft and the socket is of such form as to secure the shank in the socket, the same as I pointed out in Fig. 4 of the first Barnhart patent, and so shaped and proportioned that the rubber bushing or insert would seal and provide a flexible sealing means to exclude water from within the device.

(Testimony of William A. Doble)

The patent to Lagerblade, Defendant's Exhibit J-5, application filed June 29, 1921, discloses a golf club provided with a tapered steel tube for a handle or shaft. So it shows that this was common practice as early as 1921.

MR. GRAHAM: If the court please, I object to the witness saying that it was common practice.

THE MASTER: Yes. Just state what the patent shows here. We don't want to argue the effect of it.

A. The patent shows the head of a golf club, provided with an outwardly diverging or tapered socket. Within this socket is a tubular adapter, flexible, and, as the patent says, can be made of wood or fibre. This is a driven fit into the socket, and the adapter is provided with a tapered bore, into which the tapered tubular steel handle or shaft is tightly inserted. The tubular adapter is produced beyond the end of (156) the socket, is brought down to a thin section, and thereby provides a flexible cushion between the steel shaft and the socket, and is provided with a flexible sealing member at the thin edge of the adapter where it joins the shaft. As the inventor states, commencing with line 73, page 1:

"C is a hollow or tubular metallic shaft, which preferably tapers gradually from the grip (not shown) to the lower end, which is located concentrically within the socket. The tubular shaft is of much less diameter than the socket, and the adapter of the present invention is interposed to secure the parts firmly together and to cushion vibration and distribute the strains, as before indicated."

THE MASTER: You don't need to read all the descriptive matter into the record. Just give the page

(Testimony of William A. Doble)

and the line number. That is sufficient reference to any descriptive matter there. Just explain anything that is not understandable, and then, if you want to call attention to any particular descriptive matter, just do so by page and line, and it will probably save us time.

A. The shaft, it will be observed, is secured into the adapter and the hosel by a through pin G, so we have a taper fit, with the flexible sealing member, and the cushion for distributing the shock and vibration. And I will call the court's attention to page 2, lines 15 to 22, where it (157) points out the advantages of this construction in the prevention of the transmission of vibrations through the shaft to the operator.

Treadway, Defendant's Exhibit J-6, application filed July 14, 1922, discloses the construction of a golf club to provide torsional resilience in the mounting of the head to the shaft.

Q. BY MR. LEWIS E. LYON: Mr. Doble, is there anything particularly in this patent of importance, other than the fact that there is a steel shaft and a steel head and the section of the steel shaft within the hosel the club is slotted longitudinally in the manner similar to that disclosed by Barnhart?

A. That is the principal point showing the development of the slotted shaft, to take up the torsional, and provide torsional resilience, and also the fact that the shaft is pinned to the hosel beyond the end of the longitudinal slots.

Q. Refer to the Heller patent, Defendant's Exhibit J-7.

A. I think we might as well take up the re-issue of that patent, which is—

(Testimony of William A. Doble)

Q. (Interrupting): Is there any difference in the disclosures made by the drawings between the Defendant's Exhibit J-7 and Exhibit J-8?

A. None in the drawings, but in the re-issue of (158) it it brings out the added advantage of the torsional resilience.

MR. GRAHAM: When was that re-issue applied for; I haven't a copy of it.

MR. LEWIS E. LYON: April 8, 1927.

MR. GRAHAM: That was more than two years after the issuance of the original.

THE WITNESS: No. The original—

MR. GRAHAM (Interrupting): Was issued September 1, 1925?

THE WITNESS: The original September 1, 1925, and the application for re-issue April 8, 1927.

MR. GRAHAM: I thought you said 1928.

A. No, 1927. This patent shows a golf club with a tapered steel tubular shaft, the head of the club being provided with a tapered socket and interposed between the head and the tubular shaft is a flexible rubber cushion 7, whereby this rubber cushion provides for torsional resilience as between the head of the club and the shaft, also a cushion to absorb the shock; the upper end of the hosel is tapered to a thin edge, and there is a flexible sealing means which goes around the upper end of the hosel, the upper end of the resilient bushing which projects beyond the end of the hosel, and the flexible joint is thereby provided as a sealing means. The specifications, commencing with line 30, page 1, pointed out the advantages of the elastic (159) rebound of the head portion relative to the shaft, from a vertical and torsionally

(Testimony of William A. Doble)

displaced by the impact; this torsional resiliency being, in a large degree, lacking in steel shaft clubs as present used.

MR. GRAHAM: Are you reading from the re-issued patent?

A. Re-issued patent. That point which I read is the addition to the original patent, namely, in the later use there is introduced—

MR. GRAHAM (Interrupting): You have read that once, haven't you?

A. Partially, but I will give it to you completely, if you want it.

MR. GRAHAM: I don't care for it, if I can have a copy of the patent.

A. You will find it in the Gazettes. And, therefore, this device is provided likewise with the flexible sealing member, and though the illustration shows a wooden head, on page 2 it states "That the features of the invention may be similarly embodied in the many other types of club construction, for instance those having a metal head, such as midiron."

Q. BY MR. LEWIS E. LYON: That is the patent under which Spalding makes its clubs, is it not?

MR. GRAHAM: Objected to as calling for a conclusion, (160) there is no evidence of that kind.

THE MASTER: Sustained.

A. Then, in the Maas patent, Defendant's Exhibit J-9, application made on May 23, 1923, shows a golf club with a flexible sealing member over the upper end of the hosel and produced up onto the shaft; the upper end of the hosel being tapered to practically a feather edge, and the flexible sealing member closing over this thin edge, which would provide for a flexibility at the juncture of

(Testimony of William A. Doble)

the shaft with the head, and would therefore provide a means for waterproofing the interior of the hosel, as the celluloid ferrule makes a tight joint between the shaft and the hosel of the club head. The patent to Reach, et al., Defendant's Exhibit J-10, application filed May 12, 1926, discloses a golf club provided with a tapered tubular steel shaft; a club head provided with a tapered bore in the form of a socket, a tapered bushing within the socket which is tapered to conform to the taper of the shaft. This patent also discloses a flexible sealing member surrounding the joint between the thin upper edge of the hosel, the fiberloid bushing within the socket and extended or produced over the fiberloid coating of the shaft, thereby providing a flexible sealing member between the upper end of the hosel and the shaft, and the hosel being tapered thin at its upper end, which will provide elasticity at that point. The description of the wrapping of the fiberloid, which is of a material on the order of celluloid, is on page 1, commencing (161) with line 86.

Q. BY MR. LEWIS E. LYON: Proceed with the matter in the patent.

A. The Mattern to Crawford—

THE MASTER (Interrupting): Does that last patent teach the use of a bushing to reduce shock or a sleeve to reduce shock?

A. That is the rubber?

THE MASTER: Yes.

A. It shows a bushing in there made of fiberloid, which would have the effect of reducing shock.

Q. BY MR. LEWIS E. LYON: That is also true of the rubber sleeve disclosed in the Heller patents in Defendant's Exhibits J-7 and J-8?

(Testimony of William A. Doble)

A. More so, as it is much more resilient in that position than is the fiberloid.

Q. And in the Heller patent, Defendant's Exhibits J-7 and J-8, that rubber sleeve forms, does it not, a seal between the shaft and the club head?

A. It does, flexible.

Q. Now, the Mattern patent, Defendant's Exhibit J-11, merely discloses the use of a wrapping of the joint of the shaft and hosel of the club, of the nature to form a joint at that section which is impervious to moisture, does it not?

A. Yes, and the upper end of the hosel is tapered (162) off to a thin edge, where it joins the shaft.

Q. So as to permit of a more flexible type joint, isn't it?

A. Yes; it states on page 2 of the specifications—

THE MASTER (Interrupting): That is very, very old, the wrapping of these joints.

A. Yes, and this is interesting in that it points out the use of a rubber material which will produce a flexible wrapping. This patent is also interesting, as he states on page 2, lines 110 to 124, that he is not limiting the invention to golf clubs; that it is valuable also in the manufacture of fishing rods, polo mallets, and many other purposes.

Q. BY MR. LEWIS E. LYON: Is there anything in particular that you desire to point out from the patent, Defendant's Exhibit J-12, not shown in the previously mentioned patents?

A. Yes, in J-12 the complete shaft and its lower end is provided with a vulcanized rubber jacket which is tapered at the portion that enters the tapered socket or

(Testimony of William A. Doble)

hosel of the club, is a tight fit, and thereby provides both a flexible seal to keep water out of the hosel and also provides a cushion or yielding at the juncture of the hosel and the tapered end of the shaft. In other words, providing a shock absorber due to the flexibility of the vulcanized rubber jacket.

Q. Now, this patent to Pryde, et al.,—(163)

A. This patent also shows—

Q. (Interrupting): I mean Pryde and others states that one of its reasons is to reduce shock, does it not?

A. Yes, that is its purpose.

Q. And it discloses the use of a rubber bushing interposed between the hosel of the club head and the shaft, does it not?

A. It does.

Q. For the purpose of providing a so-called no-shock?

MR. GRAHAM: I object to counsel stating what the purposes were.

THE MASTER: Yes.

Q. BY MR. LEWIS E. LYON: I mean, as stated in the patent.

A. "This invention relates to new and useful improvements in golf clubs, and it is the object thereof, among other things, to provide a golf club wherein the shaft may have the requisite flexibility without torsional strain and without transmitting therethrough to the player using the club the shock or force of the blow or impact upon the golf ball. Defendant's Exhibit J-13, a British patent in 1913, to Saunders, discloses in 1913 the use of a tubular steel tempered shaft for golf clubs. There are several means disclosed for securing the tapered end of the shaft

(Testimony of William A. Doble)

within the hosel; the most interesting one is disclosed in Fig. 4, which shows a hosel with a— (164)

Q. (Interrupting): Mr. Doble, just a minute there. Is the showing of Figure 4 different in any way from the structure or manner of securing the head as shown by Defendant's Exhibit G?

MR. GRAHAM: We object to that, as an old form of shaft.

MR. LEWIS E. LYON: You have not been willing to admit before that that is old.

MR. GRAHAM: I think that appears in the record.

A. This Fig. 4 discloses substantially the means for attachment, as shown in Defendant's Exhibit G.

THE MASTER: Does it have any disclosure as to the use of a rubber bushing or resilient bushing or a slotting to reduce shock?

A. No, your Honor. It simply shows the hosel (165) tapered up towards its upper end to a very thin degree so as to produce resilience at that point, as pointed out in Figs. 1 and 6 of the second Barnhart patent, and thereby the deflection would be transmitted through a greater length.

THE MASTER: The same as in any other club of that fit?

A. It is a tight tapered fit, but he also provides that he would warm up the socket, and get the benefit of a shrink on the shaft, so as to increase the tightness.

THE MASTER: Well, we are not concerned with that now.

A. In other words, this is substantially the construction of defendant's club, below the little rubber collar.

MR. LEWIS E. LYON: You may cross-examine.

(Testimony of William A. Doble)

CROSS-EXAMINATION.

Q. BY MR. GRAHAM: As I understand your testimony with relation to this British patent you just referred to, Defendant's Exhibit J-13, is that the tapered end of the shaft is secured in the hosel by means of a rivet, is that correct?

A. Not entirely. The shaft is a tight driving fit, the tapered end of the shaft is a tight driving fit into the tapered hosel, and is then further secured by a cross rivet, (166) and in putting them together the heat is used, so as to shrink it that much tighter onto the tapered end of the shaft, and also makes provision for electrically spot welding the extreme end of the shaft to the hosel.

Q. Well, the shaft has two ends. One end is the handle and the other end is the smaller tapered end which is secured to the hosel; is that correct?

A. Yes, and that is the end I have been talking about.

Q. In that illustration in Figure 4 of the British patent, the rivet or pin goes through the tapered end of the hosel; is that correct?

A. No. It *does* through the hosel at about the middle of its length.

Q. And through the tapered end of the shaft, I meant to say.

A. And it goes in through the tapered end of the shaft. It goes through the tapered portion of the shaft at about its—

THE MASTER: Let us not argue about this. How far up from the end, assuming that that is a normal size club there, how far from the end of the shaft is the pin put through?

A. It is half-way of the length of the hosel.

(Testimony of William A. Doble)

Q. BY MR. GRAHAM: Did I understand you to say that is substantially like the defendant's structure?

A. Substantially like the defendant's structure, (167) in the tapered fit of the shaft and the tapered hosel, and the pin driven through the hosel and the shaft at about the middle of the length of the hosel.

Q. You don't call that the end of the shaft, do you?

A. No.

Q. Where does the end begin and where does it stop?

A. The end begins and stops at the end, and no place else.

THE MASTER: Just point out what is the end there.

A. Here, where my finger is, is one end of the shaft, and now at the other end of the shaft, and that is strictly all the end of the shaft means, in accordance with the Barnhart patents.

THE MASTER: Your definition is a two dimensional thing; is that it?

A. Yes, and that is what the patents mean.

THE MASTER: You couldn't put a pin through something that only had two dimensions?

MR. LEWIS E. LYON: The patent does not disclose putting a pin through.

MR. GRAHAM: I beg your pardon. I call your attention to Figure 5 of Barnhart's second patent, Exhibit 2, I believe, and that has a pin through it, hasn't it?

A. Yes, it has, and as near the extreme end of the shaft as they could get it.

Q. You wouldn't call that through the end? (168)

A. Approximately there. As far as the effect is concerned, it is between the end of the spiral slots, where they terminate, and the end of the shaft. Of course, to

(Testimony of William A. Doble)

put a pin through you have to come back far enough to have metal to get it through.

Q. Calling your attention to this Figure 4 in the British patent, Defendant's Exhibit J-13, I notice a pin is through substantially half-way from the bottom to the top of the hosel; is that correct?

A. Yes, that is what I said.

Q. As far as that construction is concerned, as long as the shaft metal is touching the walls of the hosel—

A. You are speaking too loud, Mr. Graham. I can't hear you.

Q. I beg your pardon. As long as the metal of the shaft is in contact with the metal of the hosel, it wouldn't make any difference in the construction of the club shown in Figure 4 of the British patent whether that pin was higher or lower on the shaft, would it?

A. Well, as a matter of mechanics, we would put it substantially in the middle.

Q. I didn't ask you that. Please answer the question.

A. Yes, it might.

Q. Might what?

A. Because, if you put it right at the extreme end of *of* the shaft, the small amount of metal there would be weak, (169) and there would be a tendency for the end of the shaft to split.

Q. Well, I expect you to use ordinary common mechanical sense that a man ordinarily skilled in that kind of work would use. I asked you whether or not that pin could not be put through above or below where it is shown in Figure 3 of the drawing, without in any sense weakening or detracting from the value of the connection between the shaft and the hosel.

(Testimony of William A. Doble)

MR. LEWIS E. LYON: Objected to as argumentative, and already asked and answered.

THE MASTER: Overruled.

A. Physically it could be put above or below, but mechanically it is better to put it in the mean of the length, so as to keep the stresses, if it was put too high, from concentrating at the hole of the pin and causing the shaft to break, or, in putting it *to* near the extreme end, causing the shaft to split. The maximum value is gained by placing it just as Saunders shows in his Figure 4.

Q. Then I understand that the only limits as to the point which that pin should be placed through there are that it must not be placed so near the upper end of the hosel as to weaken the shaft where it bends over the hosel, or that it must not be put so near the lower end of the shaft that there is not sufficient metal left, when it is likely to cause the shaft to break at that point; is that correct? (170)

A. That is about the mean position, but you can't do that in carrying out the teachings of the Barnhart patent.

THE MASTER: No, not the Barnhart patent. Let us not get into that now. You can answer that yes or no.

THE WITNESS: I think it has been answered.

THE MASTER: Yes, but you went on to considerable more there.

Q. BY MR. GRAHAM: In all these patents that you have testified to in the prior art, will you please show me one patent where you have a metal shaft—

A. Mr. Graham, would you please lower your voice?

Q. Pardon me. I am sorry. Will you point out one patent in the prior art which shows a metal shaft engaged within and in contact with the metal walls of the hosel, in which provision is made for absorbing shock?

(Testimony of William A. Doble)

MR. LEWIS E. LYON: That is objected to as immaterial. There is no disclosure in the two patents in suit of any absorption of shock.

THE MASTER: Overruled.

MR. LEWIS E. LYON: Note an exception.

A. Yes. Take the Treadway patent, Defendant's Exhibit J-6.

Q. What is the provision there made for absorbing (171) shock?

A. You have those slots, and then you have a soft wood filler core 13, filling the inner end or the inside of the tubular channel.

Q. All right. Is that the nearest one you can find, and the only one you can find?

A. Well, that answers your question.

Q. Please point out any others.

THE MASTER: How about those Lard patents?

A. The Lard patent, J-3, shows—

MR. LEWIS E. LYON: And how about the Robertson patent, J-1?

MR. GRAHAM: I think the witness should testify to this. If we are all going to help him he may find lots of things.

A. The Lard patent, Defendant's Exhibit J-3, shows the metal hosel, the tapered end of the shaft driven into it, and—

Q. Pardon me. Where is the metal hosel? (172)

A. At 4, the tapered metal hosel.

Q. As I read the description, 4 is a plug inside of the shaft.

A. As I read it, 1 is the plug.

THE MASTER: 4 is the tubular socket member.

(Testimony of William A. Doble)

MR. GRAHAM: Are you reading the Lard patent?

THE MASTER: Yes, the first page, lines 97 and 98.

MR. LEWIS E. LYON: You are reading the wrong Lard patent, Mr. Graham.

MR. GRAHAM: There is an extra patent there that I didn't know about.

THE WITNESS: I think there is an extra copy of that in your jacket, Mr. Lyon.

MR. GRAHAM: How is that?

THE WITNESS: I think there is an extra copy of that Lard patent in your brief bag, Mr. Lyon.

MR. LEWIS E. LYON: Here is a copy, Mr. Graham.

MR. GRAHAM: What is this exhibit number?

THE MASTER: J-3

MR. GRAHAM: No wonder I couldn't find those passages he was reading there.

Q. BY MR. GRAHAM: Does that show a metal shaft, Mr. Doble?

A. It doesn't specify whether it is metal or wood. This refers to it as a shaft.

Q. In 1917 are you prepared to state whether or (173) not they had metal golf shafts?

A. Certainly.

Q. Upon what do you base that statement?

A. Well, here we have the British patent of 1913, which is on the basis of metal shafts, and from the patent art.

Q. Now will you look at the end section on those shafts in the Lard patent you have just been referring to?

A. That indicates the drawing of a wooden shaft.

Q. There is nothing in the Lard patent, is there, that states that there is a metal shaft placed in this sleeve, this metal sleeve, is there?

(Testimony of William A. Doble)

A. I think not. I think it makes no reference to the material of which the shaft is made.

Q. Are there any others? You have got now Treadway and Lard.

THE MASTER: No. The witness didn't mention the Lard patent. I just asked him about it. Does that show such an arrangement?

A. Such an arrangement, with the explanation I have made, that the shaft is not specifically stated, what it is made of, but it indicates wood.

MR. GRAHAM: I would like to come back to that Lard patent. I haven't had a chance to read it.

Q. Now, referring to the Treadway patent, which you mentioned as an example, Defendant's Exhibit J-6, there (174) is nothing shown in that patent in the way of placing any cushioning material between the shaft and the hosel, is there?

A. No, but there is in those other patents, like Lagerblade and Heller.

MR. LEWIS E. LYON: I don't believe there is in the patents in suit either.

THE MASTER: Well, Mr. Graham confined the question to where you have a metal to metal fit between the shaft and the hosel, so that eliminates any question of any patents such as Heller and Lagerblade, and so forth.

A. I would say in Treadway that I would not call that a metal to metal fit. It is a metal to metal contact, because there is necessarily a freedom of relative rotation between the two, to provide for the torsional resilience.

Q. BY MR. GRAHAM: I will ask you to go one step further. Do you find any of these patents that you have referred to which discloses a tapered metal shaft

(Testimony of William A. Doble)

inserted in a metal hosel, in which the bore of the hosel at its outer end is tapered outwardly?

THE MASTER: Tapered outwardly to a greater degree than the taper on the shaft; is that it?

MR. GRAHAM: Yes, forming a space between the shaft at the outer end of the hosel and the hosel itself.

A. Yes. The Kavanaugh patent, J-2, shows that (175) diverging socket with resilient means to absorb the shock.

Q. You are talking about this broom handle?

A. Well, it is not limited to brooms—pitch forks, spades, shovels and other things that produce shock or sudden change in forces. There is your basic idea.

Q. I didn't ask you that. I asked you whether or not you saw a metal tapered shaft seated in a metal socket. Where is that shown in the Kavanaugh patent?

A. That isn't shown in the Kavanaugh patent.

Q. Then your answer is incorrect, isn't it?

A. Well, it is as I got your question. Limited to that specific patent, no.

Q. All right. Now go a step further. Do you find in any of those patents a tapered steel shaft entering a socket in the hosel, the metal of the shaft engaging the walls of the hosel, the walls of the hosel near its outer end flaring outwardly, leaving a space between the shaft and the end of the hosel, and any material in that space at the outer end of the hosel and between the outer end of the hosel and the shaft of a yielding or shock-absorbing nature? Do you find anything of that kind in the patents that you have referred to?

MR. LEWIS E. LYON: That is objected to as immaterial. (176) There is no such disclosure in issue in

(Testimony of William A. Doble)

this case, and no such disclosure is found in either of the patents in suit.

THE MASTER: Overruled.

MR. LEWIS E. LYON: Note an exception.

THE WITNESS: Now, may I have that question again, please? Let me have it in sections.

THE MASTER: He said there wasn't any with a space there.

THE WITNESS: Yes.

THE MASTER: Are there any with that space, plus rubber or something in that space?

A. I said—

THE MASTER: It would be the same answer, I think, wouldn't it?

A. With that metal shaft in contact with the—

THE MASTER: Yes.

A. No.

Q. BY MR. GRAHAM: If you interpose a piece of rubber between two sections of metal, does it have any cushioning effect?

A. That depends upon the construction, if there is a freedom of movement relative between them; if the two members are rigidly secured to each other, in this club, (177) Plaintiff's Exhibit 3, there can be no cushioning effect because the shock has been transmitted directly from the club to the steel shaft.

MR. GRAHAM: I move to strike out all of the witness' answer with reference to this club, and what happens to that club. I didn't ask him about that. I asked the simple question whether or not rubber interposed between two pieces of steel, whether or not there was a resiliency or shock absorbing feature in the rubber.

(Testimony of William A. Doble)

A. I think it can be answered more directly.

MR. LEWIS E. LYON: It is simply illustrative of his testimony.

THE MASTER: We will take another answer.

Q. BY MR. GRAHAM: Withdraw the question, and frame it another way. Assuming that you have two pieces of metal, between which there is relative movement, and interposed between the two pieces of metal you have a strip or piece of rubber; what is the function of that rubber between the two pieces of steel?

MR. LEWIS E. LYON: Objected to as indefinite on the grounds it is no indication of how the members are secured together and what the construction of the rubber is.

THE MASTER: It is a hypothetical question. If the witness can answer it, all right.

A. If the two pieces of metal are simply separated by a rubber mat, as it were, there would be some shock absorbing (178) characteristics when the pieces of metal move with respect to each other.

Q. BY MR. GRAHAM: Now, I call your attention to this club, Defendant's Exhibit G—Is this club in evidence, your Honor?

THE MASTER: No.

Q. BY MR. GRAHAM: Assuming that the statement in the Pryde patent, which has been offered in evidence as Exhibit J-12, is correct, wherein, at page 1, line 91, it says: "With a brassie, midiron club, or the like, wherein the head is made of metal, the tubular metal shaft of the golf clubs heretofore made, have frequently broken or bent opposite the upper face of the head."

A. Where are you reading from?

(Testimony of William A. Doble)

Q. I read it correctly. Line 91, page 1, Exhibit J-12. Now, that is the form of the earlier club where you had a steel shaft simply extending and fitting tightly within the hosel, as I understand it; did you understand it that way?

MR. LEWIS E. LYON: The Pryde patent that you read from?

MR. GRAHAM: Yes.

A. There is no disclosure here as to how the upper end of that hosel is made or how it would contact with the shaft. (179)

Q. BY MR. GRAHAM: Don't you take that description to mean the metal shaft and the metal hosel like this exhibit, Defendant's Exhibit G?

A. Yes, it is—

Q. (Interrupting): I am not speaking of the purpose as shown in the Pryde patent, it is the ordinary club. Can you say whether or not that is the type of club?

A. It undoubtedly means that adjacent to this upper edge of the hosel is where the fracture takes place, but there is no showing as to that construction and whether the shaft was a tight fit or otherwise at that point.

Q. What does it mean where it says it breaks opposite the upper end of the hosel?

A. Just as I stated, it would be the line in the plane of the upper end of the hosel.

Q. Now, from your experience in mechanical affairs, why would you say it broke at that point?

A. That is a statement. I am not verifying the correctness of that statement.

(Testimony of William A. Doble)

Q. Assuming that it is correct?

A. Well, if I assume that it is correct, it is then because the stresses are concentrated in that plane.

Q. And are they so concentrated in that plane in view of the fact that the metal shaft is tight within the hosel and that the shaft's first point of bending or flexing (180) would be right where it enters the hosel?

A. No, because we take in this shaft here, the hosel is very thin at the upper end, the same as in the Figure 1 of the Barnhart second patent, so that the elasticity of that metal hosel would yield, as pointed out in the Barnhart second patent.

Q. Well then, I will ask you to look at Defendant's Exhibit H, and assume, for the purpose of the question, that that is merely a hosel with a steel shaft entering it and engaging the walls of the hosel throughout its length.

A. What about it? (181)

Q. Then is it not a fact that the breaking at the point as described in the Pryde patent would be due to the bending action of the shaft over the sharp edge of the hosel?

A. If that broke there, that would be a sharp kink in the shaft.

Q. Do you know anything about the breaking of golf shafts?

A. I have examined a lot of them.

Q. Have you ever seen any of the type I have referred to?

A. I think so.

Q. All right now, the one that you have in your hand, you see a shoulder down inside the hosel, don't you?

A. Yes.

(Testimony of William A. Doble)

Q. And isn't that the point where the strains would be localized in any bending action that takes place in the shaft?

A. It would be near that.

Q. But it would be due to that sharp shoulder, wouldn't it?

A. In this particular club it would be due to the fact that the shaft is an absolute rigid fit in the tapered bore of the hosel, and therefore as there is no chance for any other movement between the shaft and hosel, the maximum fibre stress would be approximately at that shoulder. (182)

Q. Assuming that this gasket is out, assuming that there is nothing in that cavity in the end of the hosel, then there would be nothing beyond that shoulder for engagement with the shaft, to cushion the shaft in any way, would there?

A. No. The shaft would not contact with the walls of that counter-bore.

Q. But the shaft would bend in that cavity, wouldn't it, above the shoulder?

A. It would bend or deflect.

Q. All right, now suppose that you interposed in that cavity a material having a resilient quality, a cushioning quality, that would, to a certain extent, absorb that bending action or shock, would it not?

A. Practically I should say not, for the reason that your shaft is an absolute rigid fit within the taper of the hosel, and therefore there could be no cushioning of the shock on the shaft through the instrumentality of this rubber bushing, because the shock has already been transmitted to the shaft, due to its absolute firm engagement

(Testimony of William A. Doble)

with the hosel, and therefore there can be no cushioning effect.

Q. Mr. Doble, as far as the connection between the shaft and hosel is concerned, below the shoulder, it is just the same as though it was one piece, is it not, the shaft and hosel is all one piece? (183)

A. You could say that.

Q. Now, you testified, however, there was a movement between the shaft and the hosel above that shoulder, haven't you?

A. I don't think I testified just that way. There is a chance for a slight springing action above that shoulder.

Q. And you have testified that such a springing action would take place at that point, haven't you?

A. At approximately that point, yes.

Q. All right then, if there is a relative movement at that point, that relative movement would be cushioned, would it not, by the interposition of some shock-absorbing medium in that cavity?

A. Theoretically it would be possible, but this being a yielding substance, there would be no practical cushioning from the direct impact of the club to the ball. It would be too minute.

Q. What do you base that on?

A. On my knowledge of mechanics.

Q. Wouldn't that depend on the density of the medium interposed between the hosel and the shaft?

A. Yes, but this is a very resilient material and, as you can see, it has no great power of resistance.

Q. Well, it has more resistance than air, hasn't it? (184)

A. Yes.

(Testimony of William A. Doble)

Q. Then it would operate differently with that in there and when it was not?

A. Practically, I should say not. I don't think it would be possible to measure. Theoretically you could say yes.

Q. When you have a little vibration between such a thing as a golf shaft and a hosel, it would take very little to stop such a vibration?

A. The vibration is different from the shock.

Q. Answer the question, please.

A. Make the question distinct from the question of shock we have been getting at.

Q. That is very plain, you know what vibration is, don't you?

A. I certainly do.

Q. Then answer the question.

A. May I have that question?

(Question read by the reporter)

A. I would not agree to that, because very little is an indefinite term, I don't know what you mean by it.

Q. Do you know what is meant by a sting?

A. Yes.

Q. Sting of a golf shaft?

A. Yes, I have felt it.

Q. What is it due to?

A. Due to a vibration. (185)

Q. And that vibration is due to some looseness in the club at some point?

A. O, you might call it a resonance.

Q. Where does that take place?

A. That takes place throughout the length of the shaft, substantially the length, not taking into consideration the grip.

(Testimony of William A. Doble)

Q. It is your testimony that with a gasket in there of resilient material, that there would be no different effect, I will say cushioning effect, than there would if there was simply air in that cavity, is that correct?

A. I don't think I testified to that.

THE MASTER: You said theoretically yes, but from a practical standpoint no.

Q. BY MR. GRAHAM: That is your testimony, wasn't it?

A. Yes, sir. Practically, I don't think you could measure it, that is, unless you devised some ultra sensitive testing mechanism, but not in the sense of a man's feeling it in playing the game.

Q. Did you ever try one with the cushion out, and one with it in, to see whether or not there was any principal difference in the feel?

A. No.

Q. Now, calling your attention to Defendant's Exhibit J-1, that is a fishing rod, isn't it?

A. It so states, but analogous art. (186)

MR. GRAHAM: I move to strike out the words "analogous art" as a conclusion of the witness.

THE MASTER: That part may be stricken.

Q. BY MR. GRAHAM: Now, the purpose of the construction shown in that patent is such that the rod may bend in an arc from the very tip to the very end of the butt, isn't that correct?

A. Yes.

Q. Isn't that a different problem than that of the Barnhart patents?

A. I think only reversed. The B is the hosel and the A is the shaft, and you get that yielding or bending or

(Testimony of William A. Doble)

deflecting of the small shaft A in the enlarged opening C. In other words, it can deflect throughout its length.

THE MASTER: The bending inside there would be in the opposite direction, wouldn't it, from that in the Barnhart shaft?

A. I think in the same direction.

Q. BY MR. GRAHAM: Calling your attention to Figure 5 of the second Barnhart patent, I believe it is Plaintiff's Exhibit 2, would it be possible to get the effect in that construction that is produced by the Robertson fishing rod construction?

A. Substantially, yes. They both show a chambered socket and an elastic sealing member, and the rod bending throughout its length within the cavity or chamber of the (187) socket.

Q. Where is there a cavity or any elastic sealing member in Figure 5 of the Barnhart patent?

A. Well, if you look at Figure 5 you will notice that there is an enlarged cavity within the hosel providing a clearance between the shaft and the inner wall of the hosel.

Q. Where is that, the outer end of the hosel?

A. Towards the outer end, yes. You see Figure 6—

Q. (Interrupting): I am talking about Figure 5.

A. Oh, Figure 5. Figure 5 has no enlarged cavity; the shaft being a loose fit or a working fit in the hosel. I pointed that out in my explanation of the patent.

Q. But in that form the shaft cannot bend from tip to tip, as the principle disclosed in the Robertson patent, can it?

A. It certainly can, because you have got those spiral slots that provide a resilience, so that it can bend.

(Testimony of William A. Doble)

Q. How can the shaft bend in an arc in the hosel when it is substantially in engagement with the walls of the hosel throughout its length, except at the upper end?

A. For the simple reason that you have got helical or spiral slots, so that that is simply a spiral band of flexible material, and when you put the strain in there that band of flexible material simply yields and deforms. (188)

Q. How can it bend out of a straight line if it is engaged in the walls of a hosel?

A. Because the walls are in the form of a spiral ribbon, and they yield when subjected to a tension.

THE MASTER: It winds up?

A. It bends in an arc, too. It changes the relation of that spiral ribbon so that it bends.

THE MASTER: But the ribbon winds up?

MR. GRAHAM: I think it is apparent to everybody, so there is no use of spending any more time on it.

Q. Calling your attention to Defendant's Exhibit J-5, the Lagerblade patent, that is a wooden adapter that is shown there, isn't it, wooden or fibre adapter?

A. Wooden or fibre adapter and cushioning member, sealing member.

Q. That pivoting member there simply acts as a fulcrum, if the adapter is a cushioning member?

A. Acts as a what?

Q. As a pivot.

A. No, it is put in there simply as a pin to hold and insure the parts staying in there.

Q. What do you mean by the wooden part there, the fibre part being a cushioning member?

A. Because it is resilient and forms a very excellent cushion and absorbs the shock from being transmitted

(Testimony of William A. Doble)

from the club head to the shaft, and also distributes that stress, so (189) that it would not concentrate at the one plane, and therefore the stresses are distributed, and that prevents fracture.

Q. What is meant by resonance?

A. Resonance is a resounding which is due to accumulative vibration, like in a tuning fork. The series of vibrations excite other vibrations.

Q. Then, in the sense that you have used the word "cushioning" lead would be a cushion, wouldn't it?

A. No, it would not. Lead is an inert metal, and it has no cushioning characteristics whatever.

Q. Does a wooden handle have a cushioning characteristic?

A. Very much so.

Q. Did you ever lose the head of an axe because it was loose on the wooden handle?

A. That is not your question. It may happen you leave an axe out in the sun, and it is not properly fitted, it might fly off.

Q. I have had hammers that are still tight, tight on the shaft.

A. The looseness that you speak of is due to climatic effects, leaving it out in the sun, and causing the wood to shrink.

Q. And that would not have any effect on a wooden adapter to a golf club, would it? (190)

A. No, because they are protected and don't lay around in the hot, dry sun.

Q. Calling your attention to J-9, do I understand (191) your testimony to be that that has an elastic band around it?

(Testimony of William A. Doble)

A. It certainly has a flexible sealing member.

Q. Will you answer my question, please?

A. Yes, it certainly has.

Q. An elastic band?

A. It is an elastic sleeve. Of course, a band is supposed to be narrow in reference to its length, and this is wide with reference to its length, but it is an elastic, flexible sealing member and a ferrule.

Q. I call your attention to line 70 on page 1 of that patent, where it says "a ferrule of peculiar formation and adaptability for the purposes of my invention. The said ferrule is constituted—"

A. That is line 70?

Q. Yes. "The said ferrule is constituted as a tube of plastic material, it possessing the properties of shrinking and hardening when heated or exposed to the atmosphere." would that indicate to you any elastic qualities?

A. It would when I turn over and see in the next—

Q. I am asking you about that part that I just read.

A. Not without going into it further. But when you find out that he uses celluloid for the proposition, then it explains it fully and shows that it is an elastic flexible (192) material.

Q. Is celluloid elastic?

A. It certainly is.

Q. It can be pulled out of shape and it will regain its original shape?

A. Yes. They make balls out of it.

Q. What kind of celluloid are you talking about?

A. I am talking about celluloid which is a nitro cellulose camphor compound. It is highly flexible and elastic,

(Testimony of William A. Doble)

and it is used for building up testing machines for determining elastic characteristics and points of stress in metal and steel structures, and when the stress is removed it returns to its original condition of shape and size.

Q. Calling your attention to Exhibit J-11, the structure shown there is a means for fastening the shaft to the hosel, isn't it?

A. And to provide an impervious or—

Q. Please answer the question.

A. Yes, and to provide an impervious—

MR. GRAHAM: I move to strike out the balance of the answer.

THE WITNESS: Then it isn't answering it complete. I wish the privilege of explaining the answer.

Q. BY MR. GRAHAM: I asked you whether or not it was a fastening means for securing the shaft in the hosel.

A. It is, but not limited to that. (193)

Q. You say it is to keep the moisture out of the— I am asking you, not what the patent says.

A. Yes. That is the teaching of the patent. It is a metal shaft driven tight into a tapered metal hosel, with a thinner upper edge, and with this holding and sealing means around it at the junction.

Q. It is copper wire or something of that kind, isn't it, strands connected together by soldering?

A. No; it is not limited to that. At page 2 it says: "In event that material other than metallic wire is employed, for instance, strands having rubber characteristics, such strands may be closely wrapped into tight conformity to the contour of the joint and subsequently united by vulcanizing, in situ, to form a continuous sleeve of

(Testimony of William A. Doble)

tubular form, which conforms closely to the contour of the joint." And above that it refers again to making a flexible, pliable character of device.

Q. Now, in the Reach patent, J-10, the club head and hosel has a reverse taper from that shown in any of these clubs, or in the patents in suit, hasn't it?

A. I think so. The taper in the shank of the head is tapered downwardly, that is, it is a larger diameter at the lower end than at the upper end.

Q. And that sleeve that is put in there is not an elastic sleeve, is it, calling your attention, beginning line 60 on page 1? (194)

A. He doesn't say elastic. Pyroxolin, of course, is an incorrect term, as that is what you might call the raw material.

Q. I am not talking about the wrapping and the reference to Pyroxolin. I asked you a question about the sleeve that is interposed between the shaft and the hosel.

A. That is what I am talking about. Pyroxolin is the raw material, such as gun cotton, and this is made of something of that kind as a base.

THE MASTER: This is described as a cellulose compound of Pyroxolin.

MR. GRAHAM: He refers to that above as having the quality of compressibility without elasticity.

THE WITNESS: Well, he is wrong in that, because all the cellulose compounds—

Q. That is the disclosure of the patent, isn't it?

A. That is what he says there. It is not the disclosure of the patent. The real disclosure of the patent is the sleeve of cellulose compound, and that is elastic and flexible.

(Testimony of William A. Doble)

Q. I believe you testified on cross-examination that there was no mention in these two patents in suit of any shock-absorbing quality or anything of that kind?

A. No. It discusses the question of torsional resilience and flexibility, and I don't remember the term "shock" being used whatsoever. It is all to provide means (195) for torsional and longitudinal resilience.

Q. Calling your attention to Plaintiff's Exhibit No. 1, page 1, you will notice there, beginning with line 18, that it speaks about the objects of the invention, and then goes on to enumerate and give these different objects numbers?

A. Yes.

Q. Beginning with line 60, on page 1: "Seventh, to provide a golf club of this class whereby the shock often imparted through the shaft to the hands of the player, will be reduced to a minimum."

A. At line 70?

Q. 60.

A. Yes. That is what the—that is true. But that is due to the slotting of the end of the shaft to produce the torsional and longitudinal—

Q. I didn't ask you that.

MR. GRAHAM: I move to strike out that part of the witness' answer.

THE MASTER: Yes, that may be stricken.

Q. BY MR. GRAHAM: Calling your attention to the second patent, on page 1, beginning with line 47: "Seventh, to provide a golf club having a shaft-positioning socket, on its head and a shaft mounted with one end within the socket and shiftable relative to the outer end of the latter, said socket being so constructed as to

(Testimony of William A. Doble)

prevent buckling of the shaft (196) at or near the outer end of the socket." That has reference to that cavity in the end of the socket, does it not?

A. Well, it has reference to more than that.

Q. I ask you to answer that question. It has reference to the cavity in the end of the socket, does it not, where it says "a shaft mounted with one end within the socket and shiftable relative to the outer end of the latter"?

A. Now that refers to what?

Q. That refers to the clearance in the outer end of the socket, does it not?

A. It refers to the fulcrum or pivot point which is produced by the flaring of the upper end of the socket.

Q. And that portion that I have just read to you has no mention of any slots, either longitudinal or spiral, has it?

A. That particular object?

Q. Yes.

A. No, but taking the entire specification—

Q. I am not asking you that. Answer the question.

A. I say no. I am explaining it.

Q. That is all.

A. Taking the specification as a whole—

Q. I am not taking the entire specification. I wish the witness would answer the question. (197)

THE MASTER: You will have an opportunity on redirect to go into that.

MR. GRAHAM: That is all.

THE MASTER: Any redirect?

MR. LEWIS E. LYON: Yes.

THE MASTER: How much?

(Testimony of Jack Malley)

MR. GRAHAM: Have you any other witnesses?

MR. LEWIS E. LYON: No.

MR. GRAHAM: I want to call one short witness. Can't we finish tonight? Have you got a matter set, your Honor?

THE MASTER: I have got to take this thing up that I had at noon.

MR. GRAHAM: I have got a witness here from Pasadena. He is with a golf club there, and I don't want to ask him to come again. I put him under subpoena to get him here.

THE MASTER: Do you want to withdraw Mr. Doble and put him on now, out of order?

MR. LEWIS E. LYON: I have no objection.

THE MASTER: Let us withdraw Mr. Doble and call this other witness

JACK MALLEY (199)

called as a witness in behalf of the plaintiff in rebuttal, being first duly sworn, testified as follows:

DIRECT EXAMINATION

BY MR. GRAHAM

I live in Pasadena. My business is professional golf. I have been engaged in that business since 1914. I am at present employed at the Pasadena Municipal Golf Course, Pasadena. I had had experience in making golf clubs, 20 years experience at club-making. I have made clubs or shafts and fitted them to clubs to the extent of assembling together all the heads and shafts from the factory. A club maker is considered an assembler. I have handled practically every make of golf club that is on the American market, as well as some foreign makes.

(Testimony of Jack Malley)

I am familiar with the clubs that are marketed by the Wilson-Western Sporting Goods Company, defendant in this case. I (200) recognize the club, Plaintiff's Exhibit No. 3. That is manufactured by the Wilson Company, and known as the Ogg-Mented model. Being shown another club which has no designation, that is a Wilson construction, known as the Professional model.

Q And that has its rubber gasket or cushion in it, that model that you refer to?

MR. LYON: That is objected to as really not rebuttal. This is a matter of his case in chief, rather than rebuttal.

MR. GRAHAM: No. I want to ask the witness to testify about that in a minute.

MR. LYON: It is an attempt to bring this club into issue in this case, at the present time.

THE MASTER: It may be gone into at this time.

MR. LYON: I just want that understood, is all. (201)

As to the cause of the sting that you hear people refer to in playing golf, there is such a sting in a golf club, and always has been. As to whether that is evident at any particular time or manner of handling the club, my experience has been that your sting is in hitting a golf shot, with any club made; if it is properly hit there is no sting. If a shot is hit at the center of the ball or above the center of the ball, there has been a sting. In other words, if the golf club is used (202) correctly and the ball is hit fairly, as it should be hit, you don't have the sting; there is no sensation of a sting if the shot is hit correctly.

I have obtained clubs from the Wilson-Western Sporting Goods Company of the construction of Plaintiff's Exhibit No. 3. I have purchased clubs from the Wilson-

(Testimony of Jack Malley)

Western Sporting Goods (204) Company on representations made by that company that they had particular features. As to when any such representations were made and anybody present; I can't state a definite incident or a definite time; possibly a year ago. (205) I have tried these clubs, used them.

Q What would you say with respect to this rubber insert there, whether it had any effect on the feel or the sting or the action of the club?

MR. LYON: Objected to as calling for a conclusion and on the ground there is no foundation laid for such an opinion.

THE MASTER: He may give his opinion. Overruled.

MR. LYON: Exception.

A As to my personal opinion, with the experience I have had, the old construction, which is steel against steel, you would naturally have much more of a shock than you would with a cushion top of any kind in the hosel or at the top of the hosel.

CROSS EXAMINATION

BY MR. LYON

I have not taken one of these Wilson-Western clubs and tried it, with that piece of rubber that I have referred to out of this, and strike a ball. As to whether I ever struck a ball with one of these Wilson-Western clubs, I played a set of them two years. As to whether I knew at that time whether I hit a ball incorrectly or not, so it would give the sting I refer to, I miss a good many, yes, and I got the sting. (207)

(Whereupon an adjournment was taken to Friday, June 1, 1934, at 10:00 o'clock A. M.)

(Testimony of William A. Doble)

Los Angeles, California, Friday, June 1, 1934, 10:00 A. M.

(Parties present as before.)

WILLIAM A. DOBLE (208)

(Recalled)

REDIRECT EXAMINATION

BY MR. LYON

Q Mr. Doble, in Plaintiff's Exhibit 1 is there disclosed a rubber cushion or washer member?

A No.

Q In Plaintiff's Exhibit 1 it is true, is it not, that the reference to the minimizing of the shock is described as a feature of the slotted construction?

A Yes.

Q In Plaintiff's Exhibit 2, Mr. Doble, is there any mention of the word "shock"?

A I don't find any.

Q. It is true, is it not, that in Plaintiff's Exhibit 2 the only function stated for the rubber sleeve 5 is one of excluding foreign matter or dirt from within the chamber formed by the beveling outwardly of the inner wall of the upper end of the hosel?

A Yes, and to prevent dirt and dust working into the hosel, which would interfere with the functioning of the slotted portion of the shaft, and within the chamber of the hosel. (209)

Q In Plaintiff's Exhibit 2 it is true, is it not, Mr. Doble, that there is no function attributed to the rubber sleeve 5 of any cushioning function?

A That is correct.

(Testimony of William A. Doble)

Q As disclosed in the Barnhart patent, Plaintiff's Exhibit 2, and as disclosed in the Mattern patent, Defendant's Exhibit J-11, what difference, if any, is there between the sleeve 5 of the Barnhart patent and the vulcanized rubber sleeve as called for in the Mattern patent, Defendant's Exhibit J-11?

A They are the same thing, substantially.

Q In the Heller patent, Defendant's Exhibit J-7, does the rubber sleeve 7 impart any cushioning effect between the club head and the shaft?

A Very definitely so, yes.

Q In plaintiff's Exhibit 1, is the shaft 3 in wall to wall contact with the inner wall of the hosel of the club head?

A No, only at the extreme inner end of the shaft, where it is brazed in.

Q In Plaintiff's Exhibit 2, is the shaft 3 in metal to metal contact with the inner wall of the hosel?

A No, there again there is clearance between the shaft and the bore of the hosel.

Q In Figure 5 of Plaintiff's Exhibit 2 is that clearance provided for?

A The bore of the hosel is larger than the diameter (210) of the shaft, so as to permit working clearance between them, so that relative rotational movement can take place between the shaft and the hosel, excepting at the extreme end where it is secured to the head.

MR. LEWIS E. LYON: That is all. You may cross-examine.

(Testimony of William A. Doble)

RE CROSS EXAMINATION

BY MR. GRAHAM

Q Calling your attention to the first Barnhart patent, Exhibit 1, and for the present the Figure 4 and the description on page 2 of the patent, beginning at line 68, the fastening of the shaft to the club is described as by the lead or other metal that is poured around the reduced portion of the shaft, is that not correct?

A Yes.

Q So that, as illustrated in Figure 4, and bearing in connection therewith, the description beginning with line 68, page 2, and continuing to line 90, a club can either be made with a simple fastening of the lead around the reduced portion of the shaft, or, in addition thereto, metal may be poured in around the bottom of the shaft; is that correct?

A I don't think so, because through the pouring in of lead, an inert metal, into the socket with the contraction at (211) 3 b in the shaft, 3, might retain the shaft from pulling out of the head, it would not prevent the head from rotating on the shaft unless it was brazed at the extreme end of the shaft as shown at 4 in Figure 4.

Q Isn't lead a fixing material for holding parts together?

A Not by itself; only with itself, like when you burn lead together or make a wiped joint; but it is not used as a brazing material, where you want to unite two pieces rigidly together.

Q Well, lead is used as soldering material, isn't it, for joining pieces of metal together?

(Testimony of William A. Doble)

A Straight lead is used for joining lead to lead, in burning or wiping joints, but solder contains other elements, such as tin and such other elements.

Q I call your attention to the part of the specification I referred to, where it says, "lead or other deadening material", and further down it says, at 76, that lead or other material may readily retain the shaft in position. Isn't that broad enough to include a metal that could be put in there that would retain the shaft in position?

A It might be broad enough, but there is no teaching of such material for that purpose, and if you take any of the brazing materials which you are reading in there, they would be so hot as to draw the temper out of the shaft and ruin it. Lead is not used for that purpose. (212)

Q But other material is?

A It depends on how you say that, other material. There is no disclosure teaching what that other material may be. In the light of the present art, I might say so, but that doesn't teach anything; it is too indefinite.

Q With your vast knowledge of mechanics to draw on, do you mean to say that that teaching in the patent wouldn't permit you to use some metal that would perform the function described?

A It would teach me to—

Q Please answer the question yes or no.

A I can't answer that yes or no. It would teach me that lead would be useless for the purpose, and that I would have to investigate and find some other metal that could be used, if I could find one that would be successful.

Q Do I understand, with respect to the same patent, that you state that in Figure 1 there is no metal to metal

(Testimony of William A. Doble)

contact except at the extreme lower end of the shaft or hosel?

A Yes, because in mechanics a metal to metal contact means a tight contact, like a driving fit or a shrink fit. This has a working clearance.

Q On what do you base that statement?

A From the specifications and also from the fact that the head rotates at the point 2-b with respect to the shaft 3, (213) and therefore there must be a working clearance; and again from the fact that as that torsion takes place in the slotted portion of the shaft it tends to shorten the shaft, and would draw the tapered shaft within the portion 2-b, and therefore it must be large enough so that when it is drawn in it will not be a tight fit, which would prevent the functioning of the club as disclosed in the specifications.

Q It would still be a metal to metal contact, wouldn't it?

A. Not in mechanics. We don't consider it a metal to metal contact unless it is a pressure contact. There is a working clearance there, and there may be other material in between the two metals.

Q Solder is a well known shop material, isn't it?

A Yes.

Q Calling your attention to the second Barnhart patent, Plaintiff's Exhibit 2, and with respect to the gasket or washer, do I understand your testimony that the only reference to that is to exclude dirt and dust and grit from the inside?

A As a flexible sealing material, yes, due to the flexibility of the relative movement of the parts.

(Testimony of William A. Doble)

Q Well then, it has another function, has it not, it permits flexibility and movement of the parts?

A Well, I think that is all covered in the one, when (214) you say flexible sealing member.

Q Calling your attention to page 2, line 112: "Thus, the shaft is permitted to flex, twist and expand relative to the ferrule," consequently it does have another function than merely a sealing member, does it not?

A I think that is all covered by the one term "flexible sealing material;" it goes on there and says, "And still excludes dirt, dust and grit therefrom." That is the purpose of it.

Q. Then, it is not merely a sealing member, a sealing material, but it is a flexible sealing material that permits the shaft to have the function there described, is that correct?

A Yes, it is a flexible sealing material, and that covers all that you have asked about. It is the same as it is in the prior art.

MR. GRAHAM: That is all. I move to strike that latter part of the answer.

THE MASTER: All right, that may go out.

MR. GRAHAM: That is all.

MR. LEWIS E. LYON: There is one other matter, if the court please, and it may necessitate recalling Mr. Doble for the purpose of describing this Exhibit 3.

REDIRECT EXAMINATION

Q BY MR. LEWIS E. LYON: Mr. Doble, will you take (215) Defendant's Exhibit H and Plaintiff's Exhibit 3, and holding with your left hand the head of the club, and your right hand the shaft, twist the shaft and state

(Testimony of George E. Barnhart)

with reference to those two exhibits what there is with reference to those exhibits which permits of that motion there?

MR. GRAHAM: Objected to as not sur-rebuttal.

THE MASTER: Well, to twist that, with a piece cut out, doesn't mean anything.

MR. LEWIS E. LYON: That is all, then.

THE MASTER: If that were not cut out, you could not get a perceptible twist with your hand, very well.

MR. LEWIS B. LYON: Plaintiff rests.

THE MASTER: With half of this off, it weakens it so that you could twist it materially.

MR. GRAHAM: Mr. Barnhart, will you take the stand?

GEORGE E. BARNHART (216)

called as a witness on behalf of the plaintiff in rebuttal, testified as follows:

DIRECT EXAMINATION

BY MR. GRAHAM

I have heard the testimony of the defendant's witness, Patterson, relating to some tests that he made. I believe he stated they were made with and without the gasket in the club. I have conducted tests of that kind. I have played with various types of construction, with clubs having a construction of solid metal head, with a joint such as shown in the Defendant's Exhibit B, and with clubs such as Plaintiff's Exhibit 3.

(Testimony of George E. Barnhart)

Q Please state what you found or what you observed in using those two different clubs that you have referred to.

(Objected to on the ground that no proper foundation has been laid. Objection overruled. Exception.) (217)

There was considerable shock using the defendant's Exhibit B, and there was considerable breakage. I noticed in the golf shops that there was considerable breakage in the early clubs about the hosel or about the joint between the shaft and the hosel. On the clubs having the joint reinforced, for bending over the shaft point, I found that there was less breakage, and in my playing I had less shock from hitting the ball. That is in comparison with the club having an all-metal contact of the shaft with the hosel throughout the length of the hosel, and the club like Plaintiff's Exhibit 3; however, the problem may be solved by taking the bending stresses off of the sharp point by letting the shaft flex over a curved reinforcement or in any way supporting it, then the stresses are brought in gradually to take the load off of the hosel.

MR. LEWIS E. LYON: I move to strike the statement with reference to solving the problem, as not responsive to any question.

THE MASTER: I will take it as his opinion.

I would not consider it a fair test in comparing the clubs or the action of the clubs, to take a club like Exhibit 3 and to strike a ball with the rubber gasket in the club, and then simply remove the rubber gasket.

I have secured a shaft to a hosel by using hot brass, as referred to in my patent. As to how I did that, I used an oxyacetylene flame and run the molten brass into

(Testimony of George E. Barnhart)

the hole at the small end. I couldn't notice any effect on the temper of the shaft.

With reference to this club that has a head marked "101 Professional Special," which has been testified to in the testimony of Mr. Patterson and Mr. Doble, that is my property.

Q Can you state the reason for the apparent burnt condition of the metal above the hosel and the gasket that was—

A That was—

MR. LEWIS E. LYON: Just a moment. That is objected to as not rebuttal. That is a matter that was not gone into.

MR. GRAHAM: I am just doing it to identify the club. It was (219) testified to by the other witnesses, and I am simply offering the club in evidence, and having the witness explain the apparent burnt condition of the parts of the club.

MR. LEWIS E. LYON: I don't know that it is rebuttal.

THE MASTER: I don't know that it would be of any value.

MR. LEWIS E. LYON: Because it was not identified at the time.

MR. GRAHAM: It was identified as the same construction as that shown in the defendant's catalog.

MR. LEWIS E. LYON: There was no identification of it.

THE MASTER: There are three or four clubs here.

MR. GRAHAM: It was referred to by the number of the club.

(Testimony of George E. Barnhart)

THE MASTER: Well, if it was sufficiently identified at the time you may offer it in evidence.

Q BY MR. GRAHAM: Do you know the make of club that that is?

(Objected to as not rebuttal. Objection overruled. Exception.)

It is a Wilson, I think.

(Golf club marked on the head "Professional Special 101" offered in evidence as Plaintiff's Exhibit No. 12.)
(220)

MR. LEWIS E. LYON: Objected to on the ground that it is not properly proven or identified, and it is immaterial, and not within the issues of this case.

THE MASTER: It will be received as illustrating the testimony of the previous witnesses.

MR. GRAHAM: It has been identified as like the club of the Wilson-Western catalog of 1930, and the defendant's witnesses testified that they made clubs like the catalog.

MR. LEWIS E. LYON: Exception.

THE MASTER: Well, it can't be offered as an infringing structure.

MR. GRAHAM: It has already, even in the bill of particulars, been pointed out as an infringing structure.

MR. LEWIS E. LYON: It wasn't offered on your case in chief.

MR. GRAHAM: Not the particular club, but the structure was.

MR. LEWIS E. LYON: No, it wasn't.

MR. GRAHAM: That is all.

MR. LEWIS E. LYON: There was no evidence offered of that club.

(Testimony of George E. Barnhart)

MR. GRAHAM: Do you want to ask him anything?

MR. LEWIS E. LYON: Yes.

THE MASTER: Yes. Two or three witnesses testified as to this club, but I don't know whether it was identified at that time sufficiently. We can tell from reading the testimony whether they were referring to this club or to some other. But, as illustrating this testimony, it will be received. It will be Plaintiff's Exhibit No. 12.

CROSS EXAMINATION

BY MR. LYON (221)

As to whether I have testified that I have played golf with clubs similar to Plaintiff's Exhibit 3, in so far as the hosel connection. There was a different type of shaft at the time I was particularly interested in solving this problem. The Bristol Company was putting out a seamed shaft. With that seamed shaft there was a considerable amount of breakage. As to whether the clubs that I have played with, like Plaintiff's Exhibit 3, did not have that seamed shaft, I do not recall having played with any of the plaintiff's seamed shaft construction. As to whether I happen to know of my own knowledge, or made any tests to determine what the structural steel characteristics were of the shaft which I played with in a club like Plaintiff's Exhibit 3, other than the fact that it was a steel seamed shaft, I have had metallurgical tests by the Osborn Testing Laboratories of the (222) material of the seamed shaft and the material of the Union Hardware shaft and the material of the Fork and Hoe shaft. Those metallurgical tests showed that the steel structure of the three shafts was different. With steel shafts of different construction you would expect different breaking character-

(Testimony of George E. Barnhart)

istics, particularly in regard to the type of structure, the way the steel is heat treated, the particular kind of steel, and the working of the steel during the manufacture. Those three shafts have peculiar characteristics. This Union Hardware shaft I consider as being one of the worst formations of working, that of carbonizing the steel after it is worked; in other words, it is swedge by a swedging operation, and then carbonized later, making a brittle structure. As to whether it is not a fact that the melting temperature of brass is approximately 1600 degrees Fahrenheit, I do not know the exact temperature. As to whether it is around there, I wouldn't be qualified to testify on that definitely.

THE MASTER: It is a little lower than that, isn't it? (223)

MR. DOBLE: 1650.

As to whether I would say it was around that, I wouldn't guarantee it. I know that lead is the proper drawing temperature—the melting point of lead—for making a tough steel. I wouldn't be able to give testimony on whether the drawing temperature of steel, the point at which you begin to draw the temper on the steel, is approximately 400 degrees Fahrenheit.

THE MASTER: Let us not get into that. It depends on the steel entirely.

MR. LEWIS E. LYON: That is what I meant. That is the beginning of it.

(Testimony of George E. Barnhart)

THE MASTER: Oh, some steels, their temper increases from that temperature on. Isn't that a fact, Mr. Doble?

MR. DOBLE: Yes, but those are special steels, are they not. In the steel that is used for this purpose the temper begins to run at about 380 degrees Fahrenheit, and at 700 degrees Fahrenheit or 750 we get what we call a spring tempered steel, that is, a blue tempered steel, and above that the temper dies right out.

Witness Barnhart continuing.

As to whether I poured hot brass into a structure like that illustrated in my patent, using an oxyacetylene flame, and observed no effect on the temper of the shaft, and as to whether I took the shaft out and made any determination as to whether there was any effect of the temperature on the temper of that shaft, I believe that the test that concerned me was whether the club would stand up in play. I did not find considerable breakage in the shafts of these clubs in that particular regard.

Q Not because of pouring the brass over them?

A The particular trouble that brass would give would be to soften the metal and give better characteristics to those spiral grooves.

TESTIMONY CLOSED.

IN THE DISTRICT COURT OF THE UNITED
STATES FOR THE SOUTHERN DISTRICT
OF CALIFORNIA CENTRAL
DIVISION

GEORGE E. BARNHART, —
 Plaintiff, — IN EQUITY
 vs. — No. 26-M
WILSON-WESTERN SPORTING —
GOODS CO., a corporation, —
 Defendant. —

STIPULATION RE STATEMENT OF EVIDENCE
IN NARRATIVE FORM.

IT IS HEREBY STIPULATED by and between the parties to the above entitled-cause that the foregoing is a true and correct statement of the evidence in narrative form.

Dated, Los Angeles, Cal. February 27, 1935.

Frank L. A. Graham

Attorney for Plaintiff-Appellee & Cross-Appellant.

Lyon & Lyon

Lewis E. Lyon

Henry S. Richmond

Attorneys for Defendant-Appellant and Cross-Appellee.

The above stipulation is approved, and the Statement of Evidence as lodged herein is hereby settled and allowed.

Paul J. McCormick

United States District Judge.

[Endorsed]: Lodged Oct. 23, 1934. R. S. Zimmerman, Clerk By Edmund L. Smith, Deputy Clerk. Filed Mar. 1, 1935. R. S. Zimmerman Clerk By Edmund L. Smith, Deputy Clerk.

[TITLE OF COURT AND CAUSE.]

NOTICE OF LODGMENT OF NARRATIVE
STATEMENT OF TESTIMONY.

To GEORGE E. BARNHART, Plaintiff, AND

To FRANK L. A. GRAHAM, his Attorney:

PLEASE TAKE NOTICE that the defendant above named has on the 23rd day of October, 1934, lodged with the Clerk of the above entitled Court a condensed statement of the evidence taken in the above entitled cause, in accordance with Federal Equity Rule No. 75.

Lyon & Lyon

Lewis E. Lyon

Attorneys and Counsel for Defendant

RECEIVED copy of a condensed Statement of Evidence so lodged, this 23rd day of October, 1934.

Frank L. A. Graham

Attorney for Plaintiff

[Endorsed]: Filed Oct. 24, 1934. R. S. Zimmerman,
Clerk By L. Wayne Thomas, Deputy Clerk.

[TITLE OF COURT AND CAUSE.]

REPORT OF SPECIAL MASTER.

TO THE HONORABLE JUDGES OF THE UNITED STATES DISTRICT COURT, SOUTHERN DISTRICT OF CALIFORNIA, CENTRAL DIVISION:

The undersigned, DAVID B. HEAD, appointed special master by an order entered April 5, 1934, which directed him to take and hear the evidence offered, to make conclusions as to the facts and to recommend the judgment to be entered thereon, herewith submits his report:

The cause was set down for the taking of testimony. On May 29, 1934 the following appearances were made: for the plaintiff, Frank L. A. Graham, Esq., for the defendant, Lyon and Lyon by Lewis E. Lyon, Esq. The evidence offered by the parties was received, oral arguments heard and the cause was then submitted.

The action is in equity for the alleged infringement of Letters Patent No. 1,639,547 and No. 1,639,548 Both patents relate to golf clubs and particularly to the attachment of the head of a club to a steel shaft.

Wooden shafts have been in long use in golf clubs. One objection to steel shafts is that they do not possess the same degree of flexibility and resiliency as wooden shafts. The usual point of breakage in a steel shaft is at the juncture of shaft and club head. In the testimony the witnesses frequently used the term "hosel" to designate the socket portion of the club head.

The structures described in the patents are simple in form. Figure 1 of the first patent, No. 1,639,547, shows

a club head to which an elongated ferrule, 2, is attached to form a socket for the shaft. The dotted lines indicate the length of the usual socket. The ferrule is cut out in the lower part to a size greater than that of the shaft and flared at its outer end to an inside diameter greater than that of the shaft. Between the cut out and flared portions of the ferrule is a restriction 2^b. The shaft 3 is provided with longitudinal slots 3^a. It is fixed in place by brazing, welding or soldering at the lower end.

The objects of the invention are stated in the patent at considerable length. The principal object is to provide a shaft which has greater torsional and longitudinal flexibility. When the club is used the weakened section inside the socket permits the shaft to bend longitudinally bearing against the restricted portion 2^b. It also is permitted to twist axially within the socket at the weakened section. The flared portion of the socket is designed to provide a wide area over which the shaft may bend as distinguished from the single point of bending such as found in the usual shaft and hosel. The patentee states as one object of the invention:

“second, to provide a golf club having a steel shaft in which the shaft is secured at its extreme end to the head of the club and reinforced intermediate its ends near its secured end in the form of a pivot means adapted to take the initial bending moment and considerably relieve the danger of breaking of the shaft from the head immediately at the secured portion”.

The second patent No. 1,639,548 describes a golf club similar to that of the first patent. The socket is formed in the same manner. The shaft differs in that the slots are cut in a spiral form. This construction offers less

resistance to torsional twisting when used to strike a normal blow.

Figure 6 of the second patent illustrates a construction which includes a rubber cap or sleeve, 5, which is provided for the purpose of excluding dirt from the socket while still permitting the shaft to move relative to the socket. The socket is not flared in Figure 6 but it appears to be of the alternative form shown in Figure 1. When the rubber sleeve is used with the socket of Figures 3, 4 and 5 the patent states that it may be positioned within the end of the socket and around the shaft.

The second patent describes a form of construction in Figure 5 wherein the socket is flared but not undercut. Figure 4 of the first patent shows a construction wherein the socket is flared and the undercut portion solidly filled with lead for the purpose of deadening the shock of the blow. Neither of these constructions provide for longitudinal bending of the shaft below the restricted portion of the socket, although the flared upper end permits the shaft to bend above the restriction.

Claims 11, 12, 13 and 15 of the first patent, 1,639,547, are in issue. Claim 11 is the broadest. It reads.

"11. In a golf club, a head member provided with a socket and with a shaft, the latter being secured at its one end within the inner portion of the socket, the portion of the shaft near the outer end of said socket being freely movable within and relative to and about the outer end portion of said socket to prevent buckling of said shaft at the outer end of the socket.

Claim 13 includes as an element "A ferrule for reinforcing the shaft connection of a golf club to the head thereof, comprising a long sleeve, - - -".

Claim 15 includes “- - - a head member provided with a long ferrule - - -”.

Claim 10 of the second patent, No. 1,639,548, is in issue. It reads:

“10. In a golf club, a head having a socket, a shaft secured at one end within said socket, the portion of the shaft within the outer end of the socket being movable relative to the latter, and a flexible sealing member positioned at the joint between the outer end portion of said socket and said shaft.”

PRIOR ART

The prior art patents are designated as exhibits J-1 to J-13, inclusive. Treadway, Exhibit J-6, Maas, Exhibit J-9, Reach, Exhibit J-10, Mattern, Exhibit J-11, and the British patent, Exhibit J-13, were considered by the Patent Office during the pendency of the applications for the patents in suit.

Treadway, Exhibit J-6, shows a golf club with slots cut in the portion of the shaft which fits in the hosel. The hosel is of the conventional type with the socket closely fitting the shaft at all points. In the socket there is no flared portion above a restricted section. The claims in issue are directed solely to a flared construction. Treadway does not anticipate this feature of Barnhart's disclosure.

Maas, Exhibit J-9, Reach, Exhibit J-10, Matters, Exhibit J-11, Sanders, Exhibit J-13, likewise disclose sockets which fit the shaft tightly at all points. Reach shows a fiberloid sleeve, 5, fitted around the junction of the shaft and hosel which functions to exclude dirt from the socket. Sanders in Figure 7 shows a wrapping which serves the same purpose. Mattern used a wire wrapping at the same

point which may be covered with solder. In none of these constructions is there relative movement between the hosel and the shaft or is any provision made for positioning a sealing means between the hosel and the shaft.

It appears that the claims in issue were properly allowed over the prior art cited by the examiner.

The other patents in evidence are pleaded in answer but were not considered by the Patent Office.

Robertson, Exhibit J-1, concerns a fishing rod. The handle is cut out to permit longitudinal movement of the rod within the cut out portion. The rubber bushing, g, provides a fulcrum point and excludes dirt from the bore in the handle. The outer portion of the handle is not flared and the bushing forms the joint between the handle and rod. These features distinguish this structure from those of the patents in suit.

The cushioned hammer head of Isham, Exhibit J-4, and the pivoted broom handle of Kavanaugh, Exhibit J-2, do not appear to be relevant.

Lard, Exhibit J-3, is the closest reference to the combination of claim 10 of the second patent. This patent is concerned with the attaching of wood shafts to wood club heads. A tube, 4, is inserted in the socket of the club head. At the neck of the club head is a small projection, 3. A washer of leather or other suitable material, 14, is positioned around the tube 4 and against the club head. Other washers may be placed above the first washer. The patent states that the washers lessen the tendency of the shaft to break at that point and that they serve to exclude moisture from the socket. At the point where the washers are positioned there is no relative movement be-

tween the socket and the shaft. The socket is not flared above a restricted section.

The patents to Lagerblade, Exhibit J-5, Heller, Exhibits J-7 and J-8, and Pryde, Exhibit J-12, disclose the use of some resilient material for the purpose of reducing shock. Wrapping at the juncture of shaft and hosel is shown by Pryde and Heller. None shows the use of a flared socket.

VALIDITY

As before noted the claims of the first patent in issue are limited to the flared end portion of the socket which functions to lessen the strain on the shaft at the point of juncture with the hosel. Other claims of the patent are directed to combinations which include the slotted feature of the shaft. The claim of the second patent in issue is directed to the combination of a flexible bushing and the flared socket without regard to the slotted shaft.

At first glance it would appear that the flaring of the outer portion of the socket would be an obvious way in which to distribute the strain at the point of juncture of the shaft and hosel. However an examination of the prior art patents does not disclose any suggestion of such a construction. This tends to strengthen the presumption of invention.

It is concluded that Claims 11, 12, 13 and 15 of the first patent No. 1,639,547 are valid.

Claims 13 and 15 specify a long ferrule or a long sleeve. The patent describes a ferrule longer than that

of the conventional hosel. (See Figure 1 and descriptive matter beginning on Page 1, line 96). Obviously these claims are limited to a structure having an elongated ferrule or sleeve.

Claim 10 of the second patent was allowed without comment by the Patent Office. Other claims drawn to the construction of Figure 6 were rejected. The patent to Lard, Exhibit J-3, was not cited. The function of the washers in Lard and the bushing of the patent is the same, i. e., to exclude dirt from the socket. However the relative movement between the shaft and socket in the structure of the patent is not found in the Lard club. The patentee's problem was to provide a sealing means which was sufficiently flexible to permit this movement. The presumption of validity has not been rebutted and it is concluded that the claim is valid. It appears that the claim should be limited to the use of a sealing member in a structure where the shaft and socket are relatively moveable in the manner disclosed by the patent.

Defendant contends that the plaintiff has never made use of his patents and that it is to be inferred from this that the disclosures lack utility. *Henry vs. City of Los Angeles* 255 F. 769. The defendant's adoption of the features of the patents here in issue is a use which tends to strengthen the presumptions of novelty and utility. *Hallock vs. Davison* 107 F. 482. *Kelsey Heating Co. vs. James Spear etc. Co.* 155 F. 976.

INFRINGEMENT

Plaintiff in his bill of particulars charges infringement by the sale of certain clubs illustrated in defendant's catalogues for 1930, 1931, 1932 and 1933.

On page 4 of the 1930 catalogue, Exhibit 8-B, is an illustration showing the construction described by the defendant as "the no-shock" hosel. Exhibit 12, a club with a cut away portion, is similar to the club illustrated in the catalogue. The shaft is closely fitted in the lower part of the socket and held in place by a pin at about the middle part of the socket. The socket is flared outward at the upper end. This permits the shaft to flex above the closely fitted portion without bending over a sharp edge. A rubber bushing is fitted around the shaft, a portion of the bushing extending down between the shaft and hosel.

The catalogue claims that this construction reduces the amount of the shock of impact that is transmitted to the hands of the player. Herein evidence was offered to the effect that this was not true and that it was merely "sales talk". This is probably the fact, but inasmuch as neither patent claims such a function, it is immaterial.

Defendant further urges that it avoids infringement for the reason that the shaft is secured within the socket at a point about 2 inches from the end of the shaft, whereas the claims in issue specify that the shaft is secured at one end in the socket. In the club illustrated in the 1930 catalogue the shaft is pinned to the club head below the flared part of the socket at a point which is substan-

tially at the end of the club. Figure 4 of the drawings of the first patent shows a construction wherein the shaft is attached solidly within the socket from the restricted portion to the extreme end of the shaft. The use of a pin which was old in the art, is equivalent to the means of affixing the shaft which are specified in the patents.

Defendant's contention that the patents are limited to a structure wherein the elements of the claims in issue are used in combination with the undercut socket and slotted shaft does not appear to be well taken. The Patent Office allowed claims including all of the elements described as well as the claims in issue which do not include the undercut socket and the slotted shaft. Again referring to Figure 4 of the first patent, a construction is found wherein the undercut socket and slotted shaft are not used. Claims drawn to subcombinations of elements are good provided that invention is present in the combination. The claims, being valid, can not be limited by reading additional elements into them.

Claims 13 and 15 of the first patent are limited by the wording of the claims to a structure with a socket longer than the conventional type. The club illustrated in the 1930 catalogue and by Exhibit 12 has the conventional type of hosel. It is concluded that claims 13 and 15 are not infringed by this club. Claims 11 and 12 are not so limited and it is concluded that these claims are infringed. Claim 10 of the second patent reads directly on this structure and it is concluded that this claim is infringed.

The catalogues of 1931, 1932 and 1933 do not clearly show the features of construction with which this case is concerned. Exhibit 3, which the plaintiff offers as illustrating an alleged infringing structure differs from the club Exhibit 12 and the illustration in the 1930 catalogue. Instead of a gradually flaring taper at the upper end of the socket, this club has a portion cut away leaving a well defined shoulder below which the shaft is tightly fitted. There is little or no distribution of strain as the shaft is free to bend abruptly at this point. It is the function of the combination of the patent to avoid this action. It is concluded that none of the claims of the first patent in issue are infringed by clubs of the type of Exhibit 3. A rubber bushing is interposed between the shaft and the cut out portion of the socket. It is concluded that claim 10 of the second patent is not infringed in view of the previous finding that Claim 10 is limited to the use of a rubber bushing in combination with the particular hosel construction described in the patent.

CONCLUSIONS

1. That title to Letters Patent No. 1,639,547 and No. 1,639,548 is vested in the plaintiff.
2. That said Letters Patent are good and valid in law.
3. That the defendant by selling and offering for sale golf clubs embodying the invention of claims 11 and 12 of Letters Patent No. 1,639,547 and claim 10 of Letters

Patent No. 1,639,548 have infringed the said Letters Patent.

4. That the defendant has not infringed claims 13 and 15 of Letters Patent No. 1,639,547.

5. That the defendants have not infringed the Letters Patent in suit by the selling and offering for sale of golf clubs of the construction shown in Exhibit 3.

RECOMMENDATION

That a decree be entered in conformity with this report and that an injunction issue against further infringing acts and that an accounting of profits and damages be had.

A draft of this report was submitted to counsel. Each party excepted to unfavorable findings and conclusions. All exceptions are disallowed. Plaintiff contends in his exceptions that the rubber bushing in Exhibit 3 is equivalent to the tapered hosel of the first patent. While both may function to reduce strain at this point, they do not do so in the same manner. There is no equivalency in the sense the word is used in patent law.

Returned herewith is the file in the case together with the exhibits, transcript of testimony and other papers filed in connection with the proceeding on reference.

Respectfully submitted,

David B. Head

[Endorsed]: Filed Aug. 10, 1934 R. S. Zimmerman,
Clerk By L. Wayne Thomas, Deputy Clerk.

[TITLE OF COURT AND CAUSE.]

DEFENDANT'S EXCEPTIONS TO THE REPORT
OF THE SPECIAL MASTER

COMES now defendant, WILSON-WESTERN SPORTING GOODS COMPANY, a corporation, and pursuant to the provisions of Equity Rule 63, makes the following exceptions to the Report of the Special Master filed herein August 10, 1934.

1. Defendant excepts to the finding of the Special Master that Letters Patent No. 1,639,547 are good and valid in law.

2. Defendant excepts to the finding of the Special Master that Letters Patent No. 1,639,548 are good and valid in law.

3. Defendant excepts to the holding of the Special Master that defendant has sold, or offered for sale, clubs like that illustrated on page 4 of the 1930 Catalogue, Plaintiff's Exhibit 8-B.

4. Defendant excepts to the holding of the Special Master that defendant has sold, or offered for sale, golf clubs embodying the invention of claims 11 and 12 of Letters Patent No. 1,639,547.

5. Defendant excepts to the holding of the Special Master that defendant has sold, or offered for sale, golf clubs embodying the invention of claim 10 of Letters Patent No. 1,639,548.

6. Defendant excepts to the conclusion of the Special Master that defendant has infringed claim 11 or claim 12 of Letters Patent No. 1,639,547.

7. Defendant excepts to the conclusion of the Special Master that defendant has infringed claim 10 of Letters Patent No. 1,639,548.

WILSON-WESTERN SPORTING GOODS
COMPANY

Defendant

By Lyon & Lyon

Lewis E Lyon

Its Attorneys and Solicitors

[Endorsed]: Filed Aug. 15, 1934. R. S. Zimmerman,
Clerk By L. Wayne Thomas, Deputy Clerk

[TITLE OF COURT AND CAUSE.]

PLAINTIFFS EXCEPTIONS
To
MASTER'S FINAL REPORT.

NOW COMES Plaintiff and files his Exceptions to the Special Master's Final Report in the above entitled cause, pursuant to the provisions of the Equity Rules.

EXCEPTION NO. 1.

The Master erred in not finding claim 10 of patent No. 1,639,548 infringed by the club shown in Plaintiff's Exhibit 3.

Dated at Los Angeles, California this 28th day of August 1934.

Frank L A Graham
Attorney for Plaintiff.

[Endorsed]: Filed Aug 29, 1934. R. S. Zimmerman,
Clerk By L. Wayne Thomas, Deputy Clerk.

[TITLE OF COURT AND CAUSE.]

STIPULATION ADOPTING MASTER'S REPORT
as
FINDINGS OF FACT AND CONCLUSIONS OF
LAW.

It is stipulated and agreed by and between the parties to the above entitled cause through their respective attorneys that the Final Report of the Special Master filed herein be and the same is hereby adopted as Findings of Fact and Conclusions of Law in conformance with the requirements of the Equity Rules.

Dated at Los Angeles, California, this 21st day of September, 1934.

Frank L A Graham
Attorney for Plaintiff

Lyon & Lyon
Lewis E Lyon
Attorneys for Defendant

IT IS SO ORDERED.

Paul J. McCormick
Judge.

[Endorsed]: Filed Sep. 24, 1934 R. S. Zimmerman
Clerk By B. B. Hansen Deputy Clerk.

IN THE UNITED STATES DISTRICT COURT
SOUTHERN DISTRICT OF CALIFORNIA
CENTRAL DIVISION

—o0o—

GEORGE E. BARNHART,)	
	(
Plaintiff,)	
	(IN EQUITY
vs.)	
	(No. 26-M.
WILSON-WESTERN SPORTING)		
GOODS CO., a corporation,	(
)	
Defendant.	(

—o0o—

INTERLOCUTORY DECREE

THIS CAUSE having come on regularly to be heard upon exceptions to the Master's Report and upon the pleadings and proofs filed and produced on behalf of both parties, and the Court having considered the same and argument by both parties.

IT IS HEREBY ORDERED, ADJUDGED AND DECREED AS FOLLOWS:

1. That plaintiff GEORGE E. BARNHART is the rightful owner of United States Letters Patent No. 1,639,547 granted on the 16th day of August, 1927, en-

title "GOLF CLUBS," and that said Letters Patent No. 1,639,547 are good and valid in law, particularly as to claims 11 and 12 thereof.

2. That plaintiff GEORGE E. BARNHART is the rightful owner of United States Letters Patent No. 1,639,548 granted on the 16th day of August, 1927, entitled "GOLF CLUB," and that said Letters Patent No. 1,639,548 are good and valid in law, particularly as to claim 10 thereof.

3. That subsequent to the granting of the said Letters Patent No. 1,639,547 and No. 1,639,548 and within six (6) years prior to the filing of the Bill of Complaint herein, within the Southern District of California, Central Division, the defendant WILSON-WESTERN SPORTING GOODS CO., without the consent of the plaintiff, has infringed upon said Letters Patent No. 1,639,547 and particularly claims 11 and 12 thereof, and has infringed upon said Letters Patent No. 1,639,548 and particularly claim 10 thereof, by selling and offering for sale golf clubs constructed as illustrated on page 4 of defendant's 1930 catalogue, Exhibit 8-B and the club Exhibit 12, embodying the invention set forth in claims 11 and 12 of patent No. 1,639,547 and claim 10 of patent No. 1,639,548.

4. That defendant's golf clubs constructed as illustrated on page 4 of defendant's 1930 catalogue, Exhibit 8-B and the club Exhibit 12, do not infringe claims 13 and 15 of Letters Patent No. 1,639,547.

5. That the claims in issue of the Letters Patent in suit, to-wit, claims 11, 12, 13 and 15 of Letters Patent No. 1,639,547 and claim 10 of Letters Patent No. 1,639,548 are not infringed by defendant's golf clubs shown in Exhibit 3.

6. That plaintiff recover from the defendant the profits and gains which the defendant has derived or received, by reason of the aforesaid infringement of said Letters Patent No. 1,639,547 and No. 1,639,548, and plaintiff recover from said defendant any and all damages by plaintiff sustained by reason of the said infringement.

7. That this cause is hereby referred to DAVID B. HEAD, ESQ. as Special Master pro hac vice to ascertain, take, state and report an account of the said profits and gains, and to assess such damages and report thereon with all convenient speed; that the defendant, its officers, agents, servants, employees and attorneys are directed and required to attend before said Master from time to time as required and to produce before him such books, papers, vouchers and documents and to submit to oral examination as the Master may require.

8. That defendant WILSON-WESTERN SPORTING GOODS CO., its officers, agents, servants, employees and attorneys and those in active concert or participating with them, be and they are, and each of them is, hereby permanently enjoined and restrained from making or causing to be made, selling or causing to be sold and from using or causing to be used any golf club or golf clubs

embodying the inventions patented in any by said Letters Patent No. 1,639,547 particularly claims 11 and 12 thereof or embodying the invention patented in any by said Letters Patent No. 1,639,548 and particularly claim 10 thereof, and from infringing upon and from contributing to the infringement of the said Letters Patent or either of them; and that a permanent Writ of Injunction issue out of and under the seal of this Court commanding and enjoining said defendant, its officers, agents, servants, employees and attorneys and those in active concert or participating with them as aforesaid.

Dated this 24th day of September 1934.

Paul J. McCormick

United States District Judge.

APPROVED AS TO FORM:

Lyon & Lyon

Lewis E Lyon

Attorneys for Defendant.

Decree entered and recorded Sep. 24, 1934. R. S. Zimmerman, Clerk By B. B. Hansen, Deputy Clerk.

[Endorsed]: Filed Sep. 24, 1934 R. S. Zimmerman, Clerk By B. B. Hansen Deputy Clerk

IN THE UNITED STATES DISTRICT COURT
SOUTHERN DISTRICT OF CALIFORNIA
CENTRAL DIVISION

—0—

GEORGE E. BARNHART)	
)	
Plaintiff)	
)	IN EQUITY
vs.)	
)	NO. 26-M
WILSON-WESTERN SPORTING)	
GOODS CO., a corporation)	
)	
Defendant)	

PETITION FOR APPEAL.

TO THE HONORABLE PAUL J. McCORMICK,
United States District Judge:

The above named defendant, feeling aggrieved by the Decree rendered and entered in the above entitled cause on the 24th day of September, 1934, DOES HEREBY APPEAL from said Decree to the United States Circuit Court of Appeals for the Ninth Circuit for the reasons set forth in the Assignment of Errors filed herewith, AND PRAYS that the appeal be allowed, and that citation be issued as provided by law; AND THAT a transcript of the record, proceedings, papers and documents upon which said Decree was based, duly authenticated,

be sent to the United States Circuit Court of Appeals for the Ninth Circuit under the rules of such court in such cases made and provided;

AND YOUR PETITIONER FURTHER PRAYS that the proper order relating to security required by it be made.

DATED this 23rd day of October, 1934.

WILSON-WESTERN SPORTINGS GOODS
CO. a corporation

Defendant

By Lyon & Lyon

Solicitors for Defendant.

Lyon & Lyon

Lewis E. Lyon

Attorneys and Counsel for Defendant.

[Endorsed]: Filed Oct 23 1934 R. S. Zimmerman,
Clerk By Edmund L. Smith Deputy Clerk

[TITLE OF COURT AND CAUSE.]

ASSIGNMENT OF ERRORS.

NOW COMES the above named defendant, WILSON-WESTERN SPORTING GOODS CO., a corporation, and files the following Assignment of Errors upon which it will rely upon the prosecution of the appeal in the above entitled cause from the Interlocutory Decree entered and recorded September 24th, 1934, by this Honorable Court:

THAT the United States District Court for the Central Division of the Southern District of California erred:

(1) In failing to decree that the Bill of Complaint be dismissed;

(2) In finding and decreeing that United States Letters Patent No. 1,639,547 granted on the 16th day of August, 1927, for "GOLF CLUB" are good and valid in law;

(3) In finding and decreeing that United States Letters Patent No. 1,639,548 granted on the 16th day of August, 1927, for "GOLF CLUB" are good and valid in law;

(4) In failing to find and decree that United States Letters Patent No. 1,639,547 granted to plaintiff on the 16th day of August, 1927, for "GOLF CLUB" are void and invalid in law, particularly as to Claims 11 and 12 thereof;

(5) In failing to find and decree that United States Letters Patent No. 1,639,548 granted to plaintiff on the 16th day of August, 1927, for "GOLF CLUB" are void and invalid in law, particularly as to Claim 10 thereof;

(6) In finding and decreeing that defendant infringed Claims 11 and 12 of United States Letters Patent No. 1,639,547;

(7) In finding and decreeing that defendant infringed Claim 10 of United States Letters Patent No. 1,639,548;

(8) In failing to find and decree that defendant did not infringe Claims 11 and 12 of United States Letters Patent No. 1,639,547;

(9) In failing to find and decree that defendant did not infringe Claim 10 of United States Letters Patent No. 1,639,548;

(10) In finding and decreeing that defendant has sold or offered for sale clubs like that illustrated on page 4 of the 1930 catalogue, Plaintiff's Exhibit 8-B;

(11) In failing to find and decree that defendant has not sold or offered for sale clubs like that illustrated on page 4 of the 1930 catalogue, Plaintiff's Exhibit 8-B;

(12) In finding and decreeing that defendant has sold or offered for sale clubs like Plaintiff's Exhibit 12;

(13) In failing to find and decree that defendant has not sold or offered for sale clubs like Plaintiff's Exhibit 12;

(14) In failing to find and decree that defendant was entitled to the relief prayed for in its answer.

WHEREFORE, the appellant prays that said decree be reversed and that said District Court of the Central Division for the Southern District of California be ordered to enter a decree reversing the decision appealed from and entering a decree in favor of defendant in this cause as prayed in Defendant's Answer to the Bill of Complaint.

WILSON-WESTERN SPORTING GOODS CO.
a corporation

By Lyon & Lyon
Solicitor for said Defendant.

Lyon & Lyon
Lewis E. Lyon
Solicitors and Of Counsel
for said Defendant.

[Endorsed]: Filed Oct 23 1934 R. S. Zimmerman,
Clerk By Edmund L. Smith Deputy Clerk

[TITLE OF COURT AND CAUSE.]

ORDER ALLOWING APPEAL.

ON MOTION of Lewis E. Lyon, Esquire, one of the solicitors and counsel for the above named *plaintiff*.

IT IS HEREBY ORDERED that an Appeal to the United States Circuit Court of Appeals for the Ninth Circuit from the Decree heretofore filed and entered herein on the 24th day of September, 1934, MAY BE AND THE SAME IS HEREBY ALLOWED, and that a transcript of record, testimony, exhibits, stipulations and all proceedings be forthwith transmitted to the United States Circuit Court of Appeals for the Ninth Circuit.

IT IS FURTHER ORDERED that the bond on appeal be fixed in the sum of Two Hundred Fifty Dollars (\$250.00) to act as a bond for costs on appeal.

DATED this 23rd day of October, 1934.

Paul J. McCormick
United States District Judge

[Endorsed]: Filed Oct 23 1934 R. S. Zimmerman,
Clerk. By Edmund L. Smith Deputy Clerk.

[TITLE OF COURT AND CAUSE.]

NOTICE OF APPEAL.

To GEORGE E. BARNHART, Plaintiff; And
To FRANK L. A. GRAHAM, Counsel for Plaintiff, Los
Angeles, California.

COMES NOW the WILSON-WESTERN SPORT-
ING GOODS CO., a corporation, above named defendant,
by its counsel, and gives notice to plaintiff that an appeal
is hereby taken to the United States Circuit Court of
Appeals for the Ninth Circuit from the Decree of this
Court entered herein on September 24th, 1934, insofar as
said decree is adverse to the defendant.

DATED this 23rd day of October, 1934.

WILSON-WESTERN SPORTING GOODS CO.,
a corporation

By Lyon & Lyon

Lewis E. Lyon

Its Attorneys.

[Endorsed]: Filed Oct 24, 1934 R. S. Zimmerman,
Clerk By L. Wayne Thomas, Deputy Clerk

[TITLE OF COURT AND CAUSE.]

BOND ON APPEAL.

KNOW ALL MEN BY THESE PRESENTS:

THAT UNITED STATES FIDELITY & GUARANTY COMPANY, a corporation organized and existing under and by virtue of the laws of the State of Maryland, and duly licensed to transact business in the State of California, IS HELD AND FIRMLY BOUND to George E. Barnhart, plaintiff in the above entitled suit, in the penal sum of Two Hundred Fifty and no/100 Dollars (\$250.00), to be paid to the said George E. Barnhart, his heirs, executors, administrators and assigns, for which payment well and truly to be made, the United States Fidelity & Guaranty Company binds itself, its successors and assigns firmly by these presents.

SEALED with the corporate seal and dated this 23rd day of October, 1934.

THE CONDITION OF THE ABOVE OBLIGATION is such that, WHEREAS, Wilson-Western Sportings Goods Co., a corporation, defendant in the above entitled suit, is about to take an appeal to the United States Circuit Court of Appeals for the Ninth Circuit to reverse the decree in the aforesaid suit made and entered on September 24th, 1934, insofar as it sustains the validity of the Letters Patent in suit and finds infringement by said defendant of said Letters Patent in suit; AND,

WHEREAS, an Order has been made and entered in said cause dated October, 1934, that the bond of de-

defendant on said appeal be fixed at the sum of Two Hundred Fifty and No/100 Dollars (\$250.00);

NOW, THEREFORE, the condition of the above bond is such that if said defendant, Wilson-Western Sporting Goods Co., shall prosecute its appeal to effect and answer all costs if it fails to make good its appeal, then this obligation shall be void; otherwise to remain in full force and effect.

IN WITNESS WHEREOF, the corporate name of said surety is hereunto affixed and attested by its duly authorized attorney-in-fact and agent at Los Angeles, California, this 23rd day of October, 1934.

UNITED STATES FIDELITY & GUARANTY CO.

[Seal]

By O. D. Brick

Attorney-in-fact

EXAMINED AND RECOMMENDED for approval as provided in Rule 28.

Henry S. Richmond

Attorney for Defendant.

I HEREBY APPROVE the foregoing bond and the surety thereon.

Paul J. McCormick

U. S. District Judge.

STATE OF CALIFORNIA }
COUNTY OF Los Angeles } ss:

On this 23rd day of October in the year one thousand nine hundred and Thirty-four, before me, AGNES L. WHYTE, a Notary Public in and for said County and State, residing therein, duly commissioned and sworn, personally appeared O. D. BRICK, known to me to be the duly authorized Attorney-in-fact of the UNITED STATES FIDELITY AND GUARANTY COMPANY, and the same person whose name is subscribed to the within instrument as the Attorney-in-Fact of said Company and the said O. D. BRICK duly acknowledged to me that he subscribed the name of the UNITED STATES FIDELITY AND GUARANTY COMPANY thereto as Surety and his own name as Attorney-in-fact.

In Witness Whereof, I have hereunto set my hand and affixed my official seal the day and year in this certificate first above written.

[Seal]

Agnes L. Whyte

Notary Public in and for Los Angeles County, State of California.

My Commission Expires Feb. 26, 1937

[Endorsed]: Filed Oct 23, 1934 R. S. Zimmerman,
Clerk By Edmund L. Smith, Deputy Clerk.

IN THE UNITED STATES DISTRICT COURT
 SOUTHERN DISTRICT OF CALIFORNIA
 CENTRAL DIVISION

* * *

GEORGE E. BARNHART)	
	(
	Plaintiff)
	(
vs.)	IN EQUITY
	(NO. 26-M
WILSON-WESTERN SPORTING)	
GOODS CO., a corporation	(
)	
	Defendant	(
)

* * *

PETITION FOR CROSS-APPEAL

TO THE HONORABLE PAUL J. McCORMICK,
 United States District Judge:

WILSON-WESTERN SPORTING GOODS CO.,
 Defendant in the above entitled cause having obtained an
 allowance of an Appeal from the Interlocutory Decree
 entered herein on the 24th, day of September, 1934.

The above named Plaintiff GEORGE E. BARNHART,
 feeling *agrieved* by the Decree rendered and entered in the
 above entitled cause on the 24th day of September, 1934,
 insofar as the said Decree decrees that the golf club,
 Plaintiff's Exhibit No. 3 does not infringe claim 10 of
 Letters Patent No. 1,639,548 in suit, DOES HEREBY

PETITION FOR A CROSS-APPEAL from said Decree to the United States Circuit Court of Appeals for the Ninth Circuit for the reasons set forth in the Assignments of Error filed herewith, AND PRAYS that the cross-appeal be allowed, and that citation be issued as provided by law; AND THAT a transcript of the record, proceedings, papers and documents upon which said Decree was based, duly authenticated, be sent to the United States Circuit Court of Appeals for the Ninth Circuit under the rules of such court in such cases made and provided;

AND YOUR PETITIONER FURTHER PRAYS that the proper order relating to security required by it be made.

DATED this 24th day of October, 1934.

GEORGE E. BARNHART

By Frank L. A. Graham

His Attorney

Frank L. A. Graham

Solicitor and of Counsel

[Endorsed]: Filed Oct 24, 1934 R. S. Zimmerman,
Clerk By L. Wayne Thomas, Deputy Clerk

[TITLE OF COURT AND CAUSE.]

ASSIGNMENTS OF ERROR

NOW COMES the above named plaintiff GEORGE E. BARNHART, and files the following Assignments of Error upon which he will rely upon the prosecution of his cross-appeal in the above entitled cause from the Interlocutory Decree entered and recorded September 24th, 1934, by this Honorable Court:

THAT the United States District Court for the Southern District of California, Central Division, erred:

(1) In finding and decreeing that claim 10 of United States Letters Patent No. 1,639,548 is not infringed by defendant's golf clubs as shown in Plaintiff's Exhibit No. 3.

(2) In failing to find and decree that defendant's golf clubs as shown in Plaintiff's Exhibit No. 3 infringe claim 10 of Letters Patent No. 1,639,548.

GEORGE E. BARNHART

By Frank L. A. Graham

Attorney for Plaintiff

[Endorsed]: Filed Oct 24, 1934 R. S. Zimmerman,
Clerk By L. Wayne Thomas, Deputy Clerk

[TITLE OF COURT AND CAUSE.]

ORDER ALLOWING CROSS-APPEAL

ON MOTION of FRANK L. A. GRAHAM, attorney for the above named plaintiff,

IT IS HEREBY ORDERED that a cross-appeal to the United States Circuit Court of Appeals for the Ninth Circuit from the Decree heretofore filed and entered herein on the 24th day of September, 1934, BE AND THE SAME IS HEREBY ALLOWED.

IT IS FURTHER ORDERED, that the transcript of record heretofore ordered to be filed in connection with defendant's appeal is to be used for the consideration of this cross-appeal, the plaintiff herein being only required to print the papers pertaining to this cross-appeal, to be added to such transcript.

IT IS FURTHER ORDERED that the bond on cross-appeal be fixed in the sum of Two Hundred Fifty Dollars (\$250.00) to act as a bond for costs on cross-appeal.

DATED this 24th day of October, 1934.

Paul J. McCormick
United States District Judge

[Endorsed]: Filed Oct 24, 1934 R. S. Zimmerman,
Clerk By L. Wayne Thomas, Deputy Clerk

[TITLE OF COURT AND CAUSE.]

STIPULATION WAIVING BOND ON CROSS-
APPEAL

IT IS STIPULATED AND AGREED by and between the parties to the above entitled suit through their respective attorneys that the Cost Bond on Cross-Appeal be and the same is hereby waived.

DATED at Los Angeles, California, this 31st day of October, 1934.

Frank L. A. Graham
Attorney for Plaintiff

Lyon & Lyon
Lewis E. Lyon
Attorneys for Defendant.

IT IS SO ORDERED

Paul J. McCormick
Judge

[Endorsed]: Filed Nov. 1, 1934. R. S. Zimmerman,
Clerk By L. Wayne Thomas Deputy Clerk.

[TITLE OF COURT AND CAUSE.]

STIPULATION PROVIDING FOR THE FILING OF
ALL ORIGINAL EXHIBITS WITH THE
CLERK OF THE CIRCUIT COURT OF AP-
PEALS.

IT IS HEREBY STIPULATED AND AGREED by
and between the parties hereto that the Clerk of the Dis-
trict Court, at the expense of defendant-appellant, file all
of the original exhibits, both documentary and physical,
with the Clerk of the Circuit Court of Appeals for the
Ninth Circuit; said exhibits to be present in the Court of
Appeals at the time of the hearing of this appeal for the
use of both parties therein.

DATED this 27th day of February, 1935.

Frank L. A. Graham

Attorney for Plaintiff

Lyon & Lyon

Lewis E. Lyon

Henry S. Richmond

Attorneys for Defendant

[Endorsed]: Filed Mar 1—1935 R. S. Zimmerman,
Clerk By Edmund L. Smith Deputy Clerk

[TITLE OF COURT AND CAUSE.]

AMENDED PRAECIPE.

TO THE CLERK OF THE COURT:

WE HEREBY RESPECTFULLY REQUEST you to make a transcript of the record in the above entitled suit to be filed in the office of the Clerk of the United States Circuit Court of Appeals for the Ninth Circuit pursuant to Appeal heretofore allowed to defendant and include in such transcript of record the following:—

1. Bill of Complaint filed July 11, 1933.
2. Defendant's Motion for Bill of Particulars and extension of time for Answer, filed August 15, 1933.
3. Defendant's Notice of above Motion filed August 15, 1933.
4. Order extending time to answer entered August 15, 1933.
5. Bill of Particulars filed September 25, 1933.
6. Answer filed October 26, 1933.
7. Notice and Motion for reference to Special Master, filed March 28, 1934.
8. Affidavit of George E. Barnhart in support of Motion for Reference, filed March 28, 1934.
9. Order of Reference dated April 5, 1934.
10. Notice of setting for trial dated May 4, 1934.
11. Stipulation dated May 19, 1934.

12. Narrative Statement of Testimony lodged October 24, 1934, and as corrected and amended and agreed upon by the parties hereto.

13. Notice of Lodgment of Narrative Statement of Testimony filed October 23, 1934.

14. Report of Special Master, David B. Head, filed August 10, 1934.

15. Defendant's Exceptions to the report of the Special Master, filed August 15, 1934.

16. Plaintiff's Exceptions to Master's Report filed August 19, 1934.

17. Stipulation adopting Master's Report as Findings of Fact and Conclusions of Law, dated and filed September 21, 1934.

18. Interlocutory Decree entered September 23, 1934.

19. Petition for Appeal filed October 23, 1934.

20. Order allowing Appeal entered October 23, 1934.

21. Assignment of Errors filed October 23, 1934.

22. Notice of Appeal filed October 23, 1934.

23. Citation issued October 23, 1934.

24. Appeal Bond approved and filed October 23, 1934.

25. Defendant's Motion for Bill of Particulars (omitting the affidavit attached thereto.)

26. Stipulation re Book of Exhibits and physical exhibits.

27. Petition for Cross Appeal.

28. Order allowing Cross-Appeal.
29. Citation on Cross-Appeal.
30. Assignment of Errors on Cross-Appeal.
31. Stipulation waiving bond on Cross-Appeal.
32. This Amended Praecipe.

IT IS HEREBY STIPULATED by and between the parties hereto that plaintiff and defendant's praecipis heretofore filed herein be withdrawn, and that this Amended Praecipe be filed in place thereof and shall constitute the praecipe for the record in both the appeal and the cross-appeal.

DATED at Los Angeles, California, this 27th day of February, 1934.

Lyon & Lyon
Lewis E. Lyon
Henry S. Richmond
Attorneys for Defendant.

Frank L. A. Graham
Attorney for Plaintiff.

[Endorsed]: Filed Mar 1—1935 R. S. Zimmerman,
Clerk By Edmund L. Smith Deputy Clerk

[TITLE OF COURT AND CAUSE.]

CLERK'S CERTIFICATE.

I, R. S. Zimmerman, clerk of the United States District Court for the Southern District of California, do hereby certify the foregoing volume containing 186 pages, numbered from 1 to 186 inclusive, together with Volume II (Book of Exhibits), to be the Transcript of Record on Appeal in the above entitled cause, as printed by the appellant, and presented to me for comparison and certification, and that the same has been compared and corrected by me and contains a full, true and correct copy of the citation; citation on cross-appeal; bill of complaint; defendant's motion for bill of particulars and extension of time for answer; notice of motion for bill of particulars; order extending time to answer; bill of particulars; answer; notice and motion for reference to Special Master and affidavit of George E. Barnhart in support of motion for reference; order of reference; notice of setting; stipulation dated May 19, 1934; statement of evidence; notice of lodgment of statement of testimony; report of special master; defendant's exceptions to the report of the Special Master; plaintiff's exceptions to Master's Report; stipulation adopting Master's Report as findings of fact and conclusions of law; interlocutory decree; petition for appeal; assignment of errors; order allowing appeal; notice of appeal; bond on appeal; petition for cross-appeal; assignments of error on cross-appeal; order allowing cross-appeal; stipulation waiving bond on cross-appeal; stipulation providing for the

filing of all original exhibits with the clerk of the Circuit Court of Appeals; and amended praecipe.

I DO FURTHER CERTIFY that the amount paid for printing the foregoing record on appeal is \$ and that said amount has been paid the printer by the appellant herein and a receipted bill is herewith enclosed, also that the fees of the Clerk for comparing, correcting and certifying the foregoing Record on Appeal amount to..... and that said amount has been paid me by the appellant herein.

IN TESTIMONY WHEREOF, I have hereunto set my hand and affixed the Seal of the District Court of the United States of America, in and for the Southern District of California, Central Division, this..... day of March, in the year of Our Lord One Thousand Nine Hundred and Thirty-five and of our Independence the One Hundred and Fifty-ninth.

R. S. ZIMMERMAN,
Clerk of the District Court of the
United States of America, in
and for the Southern District
of California.

By

Deputy.

In the United States
Circuit Court of Appeals
For the Ninth Circuit.

Wilson-Western Sporting Goods Co.,
a corporation,

Appellant and Cross-Appellee,

vs.

George E. Barnhart,

Cross-Appellant and Appellee.

BRIEF FOR APPELLANT AND
CROSS-APPELLEE.

LYON & LYON, PAUL D. DANIEL

LEWIS E. LYON,

811 W. Seventh St., Los Angeles, California,

Attorneys for Appellant and Cross-Appellee.



SUBJECT INDEX.

	PAGE
Barnhart Patent No. 1,639,547.....	6
Barnhart Patent No. 1,639,548.....	9
The Barnhart Patents Nos. 1,639,547 and 1,639,548—Paper Patents	11
Defendant's Structures.....	18
Defendant's Second Structure.....	25
Prior Patented Art.....	28
Conclusion	49

TABLE OF AUTHORITIES CITED.

	PAGE
Atlantic Works v. Brady, 107 U. S. 192, 27 L. Ed. 438.....	40
Burt v. Savory, 133 U. S. 349.....	28
Chapman Dehydrater Co. v. Crenshaw, 65 Fed. (2d) 69	17
Donchian v. Kingston, 138 Fed. 895.....	33
Dowagiac Mfg. Co. v. Superior Drill Co., 115 Fed. 886.....	34
Eaid v. Twohy Bros. Co., 230 Fed. 444.....	48
Frederick R. Stearns & Co. v. Russell, 85 Fed. 218.....	42
George E. Lee Co. v. Fortified Mfg. Co., 284 Fed. 315.....	32
Great Western Co. v. Lowe, 13 Fed. (2d) 880.....	43
Hauser v. Simplex Window Co., 10 Fed. (2d) 457.....	34
Hennebique Const. Co. v. Urban Co., 182 Fed. 496.....	32
Henry v. City of Los Angeles, 230 Fed. 457.....	15
Heyl & Patterson v. M. A. Hanna Coal & Dock Co., 279 Fed. 862	24
I. T. S. Rubber Co. v. Essex Co., 272 U. S. 429, 443, 71 L. Ed. 335, 342.....	32
Knick v. Bowes Co., 25 Fed. (2d) 442.....	32
Lorraine v. Townsend, 290 Fed. 54.....	32
Murray Co. v. Sumner I. Works, 300 Fed. 911.....	41
Neva-Slip Shirt Waist Grip Co. v. Marcon Co., 215 Fed. 117....	33
Niblo Mfg. Co. v. Preston, 39 Fed. (2d) 604.....	33
Quick Action Ignition Co. v. Maytag Co., 39 Fed. (2d) 595.....	33
Riverside Heights Orange Growers Association v. Stebler, 240 Fed. 703	24
Smith v. Nichols, 21 Wall. 112, 119, 22 L. Ed. 566.....	41
Stuebing Truck Co. v. Olson, 291 Fed. 63.....	33
Warren Bros. Co. v. Thompson, 293 Fed. 745.....	32
Webster's New International Dictionary.....	45
White v. Dunbar, 119 U. S. 47.....	32
Wilson & Willard Mfg. Co. v. Union Tool Co., 249 Fed. 729, 735	32

No. 7807

In the United States
Circuit Court of Appeals
For the Ninth Circuit.

Wilson-Western Sporting Goods Co.,
a corporation,

Appellant and Cross-Appellee,

vs.

George E. Barnhart,

Cross-Appellant and Appellee.

BRIEF FOR APPELLANT AND
CROSS-APPELLEE.

This is an appeal from a decree holding claims 11 and 12 of the Barnhart Patent No. 1,639,547, and claim 10 of the Barnhart Patent No. 1,639,548, valid and infringed.

A cross-appeal is taken by Cross-Appellant and Appellee from the decree holding that claim 10 of Letters Patent No. 1,639,548 is not infringed by the construction of golf club illustrated by Plaintiff's Exhibit 3.

The patents in suit are for golf clubs, and of these patents it is said:

“At first glance it would appear that the flaring of the outer portion of the socket would be an obvious way in which to distribute the strain at the point of juncture of the shaft and hosel.”

[Report of Special Master,
Record, p. 154.]

This suit was tried before a Master in Chancery, David B. Head, under an order entered April 5, 1934, directing him to take and hear the evidence, make conclusions as to the facts in issue, and record the judgment to be entered thereon, reserving to the court the full power to review to which order of reference defendant-appellant and cross-appellee excepted. [Record, p. 27.]

Pursuant to the reference, the Special Master heard the testimony, arguments of counsel, and made his report [Record, pp. 149-159] to the judges of the District Court for the Southern District of California. Under Equity Rule 66 exceptions were taken by defendant-appellant and cross-appellee to the recommendations of the Special Master. [Record, pp. 160-161.]

Plaintiff cross-appellant and appellee filed exceptions to the Report of the Special Master with respect to the holding of non-infringement of claim 10 of Letters Patent No. 1,639,548 by the structure of the golf club as illustrated by Plaintiff's Exhibit 3. [Record, p. 162.]

A hearing was had before the Honorable Paul J. McCormick, District Judge, at which hearing the Honorable Paul J. McCormick overruled the exceptions taken by both plaintiff and defendant and confirmed the report of the Special Master.

Hereafter in this brief appellant and cross-appellee will refer to the parties as they were designated before the District Court, i. e., appellant and cross-appellee as "defendant", and cross-appellant and appellee as "plaintiff".

Defendant brings this appeal upon the assignment of errors [Record, p. 170], the substance of which assignment of errors presents to this Honorable Court for its

consideration defendant's contention that the District Court erred.

(1) In holding the Barnhart Patent No. 1,639,547, and claims 11 and 12 thereof, to be infringed by the defendant's structure as illustrated on page 4 of the 1930 catalogue, Plaintiff's Exhibit 8-B;

(2) In holding that the Barnhart Patent No. 1,639,548, and claim 10 thereof, to be infringed by the defendant's structure as illustrated on page 4 of the 1930 catalogue, Plaintiff's Exhibit 8-B;

(3) In holding the Barnhart Patent No. 1,639,547, and claims 11 and 12 thereof, to be valid;

(4) In holding that the Barnhart Patent No. 1,639,548, and claim 10 thereof, is valid;

(5) In not holding that the defendant's structure as illustrated on page 4 of the 1930 catalogue, Plaintiff's Exhibit 8-B, is not of the construction as illustrated in the Barnhart Patents Nos. 1,639,547 and 1,639,548, and does not have the mode of operation allegedly produced in the use of the golf clubs of the two Letters Patent in suit to infringe claims 11 and 12 of the Barnhart Patent No. 1,639,547, and claim 10 of the Barnhart Patent No. 1,639,548.

The cross-appeal taken by defendant in substance is that the District Court erred in not holding that claim 10 of the Letters Patent No. 1,639,548 is infringed by the structure of golf club illustrated by Plaintiff's Exhibit 3.

Barnhart Patent No. 1,639,547.

The Barnhart Patent No. 1,639,547 relates to a golf club and the manner of securing a golf club head to a steel shaft. The general object of the Barnhart Patent No. 1,639,547 is to secure a steel shaft to a golf club head in such a manner as to permit of greater freedom of torsional twist and longitudinal movement of the shaft within the ferrule or "hosel" of the club head. Barnhart says:

"Steel or other metal shafts, as heretofore constructed, provide less longitudinal flexibility than wooden shafts and very little torsional flexibility and resiliency." (Barnhart Patent No. 1,639,547, p. 1, lines 13-15.)

Barnhart attempted to overcome this alleged difficulty by

(1) taking an ordinary steel head 1 and shaft 3 and cutting off the outwardly diverging shank as illustrated in dotted lines in Figure 1, and securing in its place an *elongated ferrule 2*.

(2) By securing the *extreme end* of the shaft 3 to the club head within the interior of the ferrule 2.

(3) By providing within the ferrule 2 of the club head a *chamber 2^a* to permit the *free movement* of the shaft 3 within the interior of the ferrule 2; and

(4) By providing a restriction, 2^b, within the chamber several inches from the extreme end of the shaft 3 which *loosely engages* the shaft 3.

(5) By *weakening the section of the shaft 3* within the chamber 2^a, as by forming slots 3^a, to permit of greater torsional and longitudinal flexibility.

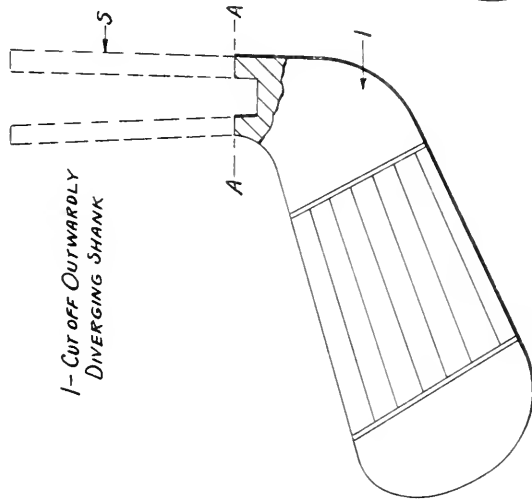
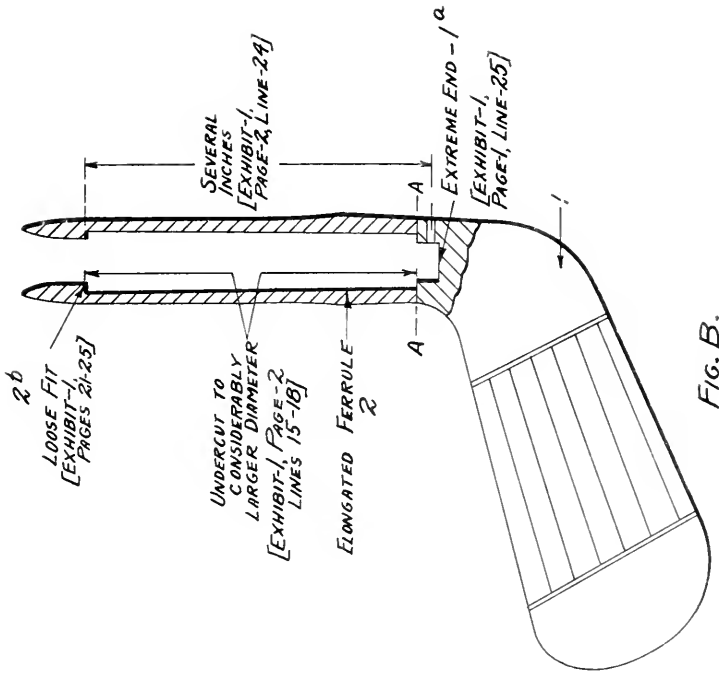



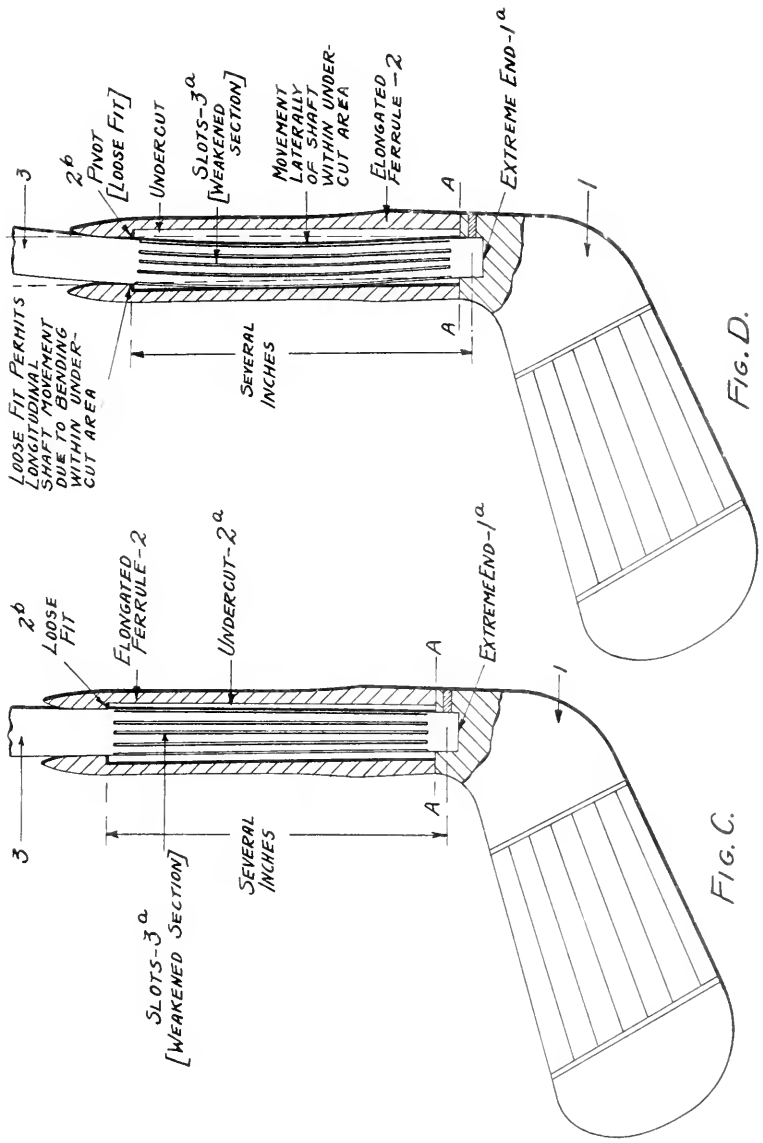



The Barnhart Patent No. 1,639,547 illustrates the manner of connection of the steel shaft 3 to the club head 1 as illustrated in the following figures A to D:

First: As illustrated in Figure A, the Barnhart Patent No. 1,639,547 states that the outwardly diverging shank S of the club head 1 is cut off at the line A in Figure A. (Barnhart Patent 1,639,547, p. 1, line 98; p. 2, line 11.)

Second: An elongated ferrule 2 is provided in the place of the outwardly diverging shank S. (a) The elongated ferrule 2 is undercut as illustrated at 2^a. (b) The elongated ferrule 2 is provided on its interior with a constricted portion 2^b which will loosely engage the shaft, as illustrated in Figure B.

“The upper end of the bore of the ferrule, indicated by 2^b, is considerably constricted and *loosely engages* the rod or shaft 3 several inches from its lower end for reinforcing the shaft.”

(Barnhart Patent No. 1,639,547, p. 2, lines 21-25.) (Italics ours.)

Third: (1) The shaft 3 is fitted to the ferrule 2 by securing the shaft 3 to the ferrule 2 at the *extreme end* 1^a of the shaft 3 as illustrated in Figure C.

“second, to provide a golf club having a steel shaft in which the shaft is secured at its *extreme end* to the head of club . . .”

(Barnhart Patent No. 1,639,547, p. 1, lines 23-26.) (Italics ours.)

The intended mode of operation of this assembly as stated by Barnhart, is as illustrated in Figure D.

(1) The shaft 3 is free to move torsionally and longitudinally within the undercut 2^a.

(2) The shaft is weakened by forming of the longitudinal slots 3^a in the portion of the shaft within the undercut 2^a of the ferrule 2.

(3) The shaft is secured at its *extreme end* to the head 1 or ferrule 2 “*several inches*” from the loosely fitting constriction 2^b.

When the head 1 strikes a golf ball, the weakened portion of the shaft 3 permits the shaft to turn at its weakened section. The weakened section of the shaft 3 likewise permits the shaft 3 to bend at its weakened section within the chamber 2^a. The elongated ferrule 2 is undercut to provide the chamber 2^a within which the shaft 3 bends above its extreme end. Several inches from the extreme end the constriction 2^b loosely engages the shaft 3 to permit the shaft 3 to move freely as it moves inwardly into the chamber 2^a due to the effects of bending and the effect of twisting. This action is testified to by the patentee, Barnhart, where he states:

“That is, the purpose of that weakening of the section of the shaft and the cutting out of that chamber or socket, as shown in Figure 3, is to permit the club shaft to bend somewhat in the manner you have sketched it in dotted lines on a copy of my patent; that in combination with torsioning effect.”

[Record, page 45.]

Defendant's expert, William A. Doble, defines this action:

“Therefore, in this club of Plaintiff's Exhibit 1, it necessarily requires, to carry out the teachings and disclosures of the patent, and it is so disclosed in the patent, that the shaft is only secured to the golf head, the club head I mean, at the extreme end of the shaft.

where it is inserted into the tapered chamber 1a' and is secured there by brazing or some similar means. The shaft above this point, in the weakened section, will therefore twist and allow the upper end of the hosel to rotate about and with respect to the shaft, and as the shaft is tapered and as this helical twisting takes place in the weakened section of the shaft, it tends to shorten the shaft and draw it within the upper end of the hosel, that is the portion 2^b; and therefore, as this shaft is tapered, there must be freedom of space between the shaft and the bore of the upper portion of the hosel. In other words, it must be a free, loose fit, or otherwise the shaft could not function as proposed, and the portion 2b' of the hosel is presumed to provide a fulcrum or pivot around which the shaft, acting as a lever, will turn."

[Record, pages 83-84.]

Barnhart Patent No. 1,639,548.

The Barnhart Patent No. 1,639,548 illustrates a golf club of a form similar to that illustrated in the Barnhart Patent No. 1,639,547. The differences are

(1) That in the place of the straight, longitudinal slots formed in the shaft 3 of the golf club of the Barnhart Patent No. 1,639,547, the second Barnhart Patent No. 1,639,548, illustrates the slots as formed helically in the shaft within the chamber 2^a of the hosel or elongated ferrule of the golf club, and

(2) In order to keep moisture, water and dirt from entering the chamber 2^a, there is illustrated in Figure 6 of the patent a flexible cap sleeve or band 5 which surrounds the outer portion of the ferrule 2 and the shaft 3

at the point where the shaft 3 emerges from the elongated ferrule 2.

With respect to this difference, Barnhart states:

“In Fig. 6 of the drawings, I have shown a flexible cap, sleeve, or band 5, around the joint between the outer end of the ferrule and the shaft for excluding dirt, dust and grit from entering the ferrule and lodging between the same and the shaft and thus preventing proper co-action between the same. The sleeve 5 is preferably made of rubber in tapered form and is positioned with its thick end around the end of the ferrule, and the thin or fin end around the shaft. Thus, the shaft is permitted to flex, twist and expand relative to the ferrule and still exclude dirt, dust and grit therefrom. It will be noted that a similar sleeve may be positioned around the joints of the ferrules and shafts shown in Figures 3, 4 and 5, or a cap, or washer may be positioned within the end of the ferrule around the shaft.”

(Barnhart Pat. No. 1,639,548, p. 2,
lines 101-119.)

As illustrated, the Barnhart Patent No. 1,639,548 differs only from the earlier Barnhart Patent No. 1,639,547 in the showing of helical slots and the showing of a rubber sleeve 5 between the end of the ferrule 2 and the shaft 3 for preventing dirt, moisture and grit from entering the chamber 2^a.

As to this second Barnhart Patent No. 1,639,548, the Special Master's Report states:

“It appears that the claim should be limited to the use of a sealing member in a structure where the shaft and socket are relatively moveable in the manner disclosed by the patent.” [Record, p. 155.]

**The Barnhart Patents Nos. 1,639,547 and
1,639,548—Paper Patents.**

The Barnhart Patents Nos. 1,639,547 and 1,639,548 are paper patents. This fact is established by the testimony of the patentee Barnhart who states:

“As to whether I ever manufactured any club for the market of the character as disclosed in either of my patents in suit, I made them for the purpose of demonstrating the principle only. I made some clubs. I never endeavored to sell any such clubs.

“I have endeavored to obtain some manufacturer of golf clubs or golf shafts who would take a license under my patents. As to whether any such party has ever taken any such license, the Wilson-Western Sporting Goods Company have tentatively opened up negotiations. They made the request to supply them with a price in the matter. They did not, however, take a license and no one else has taken any. As to whether I have submitted the matter in the same manner to Spaldings, Spaldings are probably affected quite differently than Wilson-Western.”

[Record, p. 46.]

Not only are the Barnhart patents in suit merely paper patents, but they do not teach the art any step forward in connection with the construction of a steel shaft club. The alleged problem, the Barnhart patents state, is to secure a steel shaft to a golf head in a manner to provide greater flexibility and resiliency, both longitudinally and torsionally, in such a manner as to eliminate the breakage of the shafts at the point of joinder of the shafts with the heads. Barnhart states:

“In golf clubs now in use, the shafts are made of wood as well as of steel tubing. Although the golf clubs with wooden handles provide greater flexibility and resiliency both longitudinally and torsionally, the same *break frequently* at the portions directly secured to the heads.”

(Barnhart Patent No. 1,639,547, p. 1,
lines 4-13.) (Italics ours.)

Further Barnhart states:

“second, to provide a golf club having a steel shaft in which the shaft is secured at its *extreme end* to the head of the club and reinforced intermediate its ends near its secured end in the form of a pivot means adapted to take the initial bending moment and considerably relieve the danger of breaking of the shaft from the head immediately at the secured portion;” (Barnhart Patent No. 1,639,547, p. 1,
lines 23-31.) (Italics ours.)

The second Barnhart Patent No. 1,639,548, states:

“and, tenth, to provide a means of this class which is simple and economical of construction, durable and which will not readily deteriorate.”

(Barnhart Patent No. 1,639,548, p. 1,
lines 61-64.)

That Barnhart did not solve the alleged problem he thus set out to solve is established. Barnhart states:

“I don't believe I have those clubs at the present time. I have had breakage of the shafts. As to whether there was considerable breakage with those shafts and those club heads, in the spiral there was quite a problem in overcoming breakage,”

[Record, p. 47.]

It is asserted by the plaintiff that the golf clubs of Plaintiff's Exhibit 3 and of the structure illustrated on page 4 of the 1930 catalogue, Plaintiff's Exhibit 8-B, infringe the patents in suit; therefore, that these clubs are constructed in accordance with, and have the same mode of operation as do the clubs constructed as illustrated in the two Barnhart patents in suit. The record shows that the structure of club illustrated on page 4 of the 1930 catalogue, Plaintiff's Exhibit 8-B, has been abandoned by defendant because the breakage of shafts was so great as to render the construction impractical; and secondly, that the breakage of the shafts of the clubs constructed as illustrated by Exhibit 3 is so great that defendant is now offering for sale a different club of an entirely different construction where the shaft is rigidly and positively secured to the head. The model of defendant's clubs as actually taken from the shelves of the Wilson-Western Sporting Goods Company is offered in evidence as Defendant's Exhibit "H". Horace E. Gillette, manager of the Wilson-Western Sporting Goods Company, Los Angeles Branch, testified:

"With this club Defendant's Exhibit H and of this same construction, the Wilson Company has some difficulty with shaft breakage. In most cases the shaft breaks about a quarter of an inch below the top of the hosel." [Record, p. 55.]

As between the clubs of defendant's construction those which have the rubber bushing between the hosel and the shaft break more frequently than the clubs which do not have the rubber, but where the shaft is merely a driven tapered fit.

Thomas J. Flynn, Assistant Branch Manager of the Wilson-Western Sporting Goods Company, Defendant's Los Angeles Branch, who controls the ordering of merchandise and the matter of adjustment with respect to defective merchandise, testified:

“The difference in the breakage between those clubs that do and those which do not have the rubber in there is that the ones with the rubber break more frequently, than those without it.”

[Record, pp. 67-68.]

It is therefore evident that the theoretical teachings of the patents in suit in so far as they relate to, if at all, defendant's structures, is that they have not taught the elimination, or even an improvement, in the condition of shaft breakage. The new club of the Wilson-Western Sporting Goods Company, defendant, that is, the Oggmented club, in order to overcome this problem of shaft breakage, has the shaft formed with a bulge at the point of joinder of the shaft and hosel of the club head so as to place a greater strength of material at this point of weakness and the shaft is sweated firmly into the hosel to produce substantially a solid metal construction.

“This Oggmented club that I have been testifying about really first appeared the latter part of last year, when we usually get our new golf club models for the ensuing year. At that time we had samples only. They really didn't have much sale until lately. In other words, it has just gone on the market this year. That high powered Croydon type that I have referred to is not a straight steel shaft. It is a shaft that is constructed in the same design of the original hickory shaft, that is to say, it is large at the top and tapers

down to its smallest diameter within three or four inches of where it enters the hosel; and at that point it enlarges until it gets to the hosel and then it tapers off small again to fit into the hosel of the head. In fact, it has quite a bulge right above the hosel. That is not a new feature this year. We had that last year but not in the Oggmented club. We had it in the professional Special.” [Record, p. 66.]

“In clubs made with those shafts, the shaft is sweated or soldered to the club head and then pinned.” [Record, p. 65.]

The patents in suit are mere paper patents. They are based upon a mere theory or idea and have never had any practical use whatsoever. Plaintiff has never marketed any of the clubs of the construction therein illustrated. The major club manufacturers have all turned the patents down as being for an impractical idea.

As this Honorable Court said in *Henry v. City of Los Angeles*, 230 Fed. 457 at 461; the patents under such circumstances are not entitled to a liberal application of the rule of equivalents but must be narrowly construed:

“The argument thus made by complainant concerning the patents in the prior art applies to the foregoing facts concerning the patent in suit and defendant’s device, notwithstanding that defendant’s machine has never been patented. The defendant has a successful machine; complainant has a patent on an idea or theory. Under such circumstances complainant is not entitled to that liberal application of the rule of equivalents that a patent is entitled to where the invention was the first to produce a new and useful result.”

The patents in suit and each of the claims thereof charged to be infringed, *i. e.*, each of claims 11 and 12 of the Barnhart Patent No. 1,639,547, and claim 10 of the Barnhart Patent No. 1,639,548, call for the shaft being secured to the club head at one end of the shaft. Claim 11 says:

“the latter being secured at its one end within the inner portion of the socket,”

Claim 12 says:

“the latter being secured at its one end within the inner portion of the socket,”

and claim 10 says:

“a shaft secured at one end within said socket.”

What is meant by “one end” is clearly set forth by Barnhart in the statement of his invention wherein he states:

“second, to provide a golf club having a steel shaft in which the shaft is secured at its extreme end to the head of the club.”

(Barnhart Patent No. 1,639,547, p. 1,
lines 23-26.)

This refers to the illustration contained in each of the Barnhart patents of the securing means 1^a in Figure 1 of the Barnhart Patent No. 1,639,548, and likewise in Figure 1 of the Barnhart Patent No. 1,639,547, wherein the extreme end of the shaft is brazed or otherwise secured to the club head. No contention is made that Barnhart has ever sold or offered for sale a club of this construction. Defendants never used a club wherein the extreme end of

the shaft is secured to the club head. The manner in which defendants secured their club shafts to the club head renders such securing impossible. Horace E. Gillette, manager of defendant's store in Los Angeles, testified:

"My attention being called to Defendant's Exhibit H and holes in the hosel, that is, what might be called a single hole extending from one side through to the other, that is to receive a rivet. It would make a difference in the function of the rivet if that hole for the rivet was a half an inch lower than it is here. It would crack the shaft if you put it any lower. I say that because we tried it. The factory tried quite a few of them that way. I know that of my own knowledge. I did not see them try it, but I have seen some clubs made that way and in nearly every instance the shaft cracked at the end because there was nothing to hold it." [Record, pp. 58-59.]

No use has been made of the allegedly novel conceptions or theories of the Barnhart patents in suit by either plaintiff or defendant. Plaintiff has abandoned the construction of the patents in suit and does not even contend that a club made in accordance with the theory of his patent will overcome the difficulties which he sought to solve. Barnhart's allegedly novel ideas and theories have never had a place in the practical art and have added nothing to golf club manufacture. Clearly therefore the claims sued upon are invalid.

In the case of *Chapman Dehydrater Co. v. Crenshaw*, 65 Fed. (2d) 69, at page 72, this Honorable Court was dealing with a similar circumstance and held:

"We have referred to the most recent dehydrating plants constructed by the parties merely for the pur-

poses of indicating that, if the patentee ever believed that there was any virtue in the patent claim with reference to the equal size of the dehydrating and furnace chambers, the owner of the Puccinelli patent has abandoned that construction, and the appellee and cross-appellant has not undertaken to use the idea. We conclude that claims 1 and 2 of the Puccinelli patent are not new or novel, do not constitute invention, and are anticipated by the prior patents hereinbefore referred to.”

Defendant's Structures.

The defendant's structures here involved are illustrated by page 4 of Defendant's 1930 catalogue, Plaintiff's Exhibit 8-B, and by Plaintiff's Exhibit 3, a further illustration of which is offered as Defendant's Exhibit H. A comparison of the structure of the Barnhart patents in suit with defendant's structure shows that defendant has not in any way followed any teaching or theory of either of the Barnhart patents in suit. *First*, there is no allegation of, or showing, that defendant has utilized the teaching of taking an ordinary steel head and cutting away the outwardly diverging shank and substituting therefor an elongated ferrule 2 as illustrated by Figures A and B hereof. *Second*, in defendant's structure the club shaft is not secured at its extreme end to the head 1 within the interior of the ferrule 2. *Third*, there is no loosely fitting constriction spaced several inches from the point of securing of the shaft to the club head providing a loose fit permitting movement of the shaft as it bends or twists within the interior of the shaft ferrule or hosel. *Fourth*. There is no weakening of the club shaft within the interior of the hosel to permit the shaft to have a greater torsional

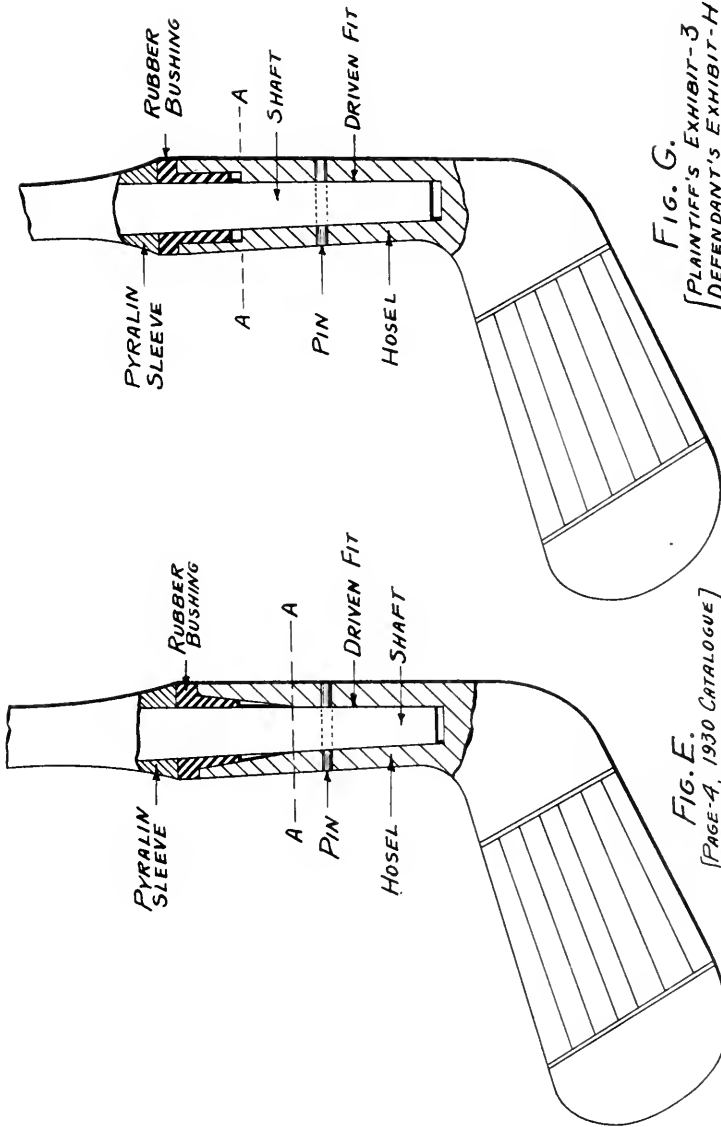

FIG. G.
[PLAINTIFF'S EXHIBIT-3]
[DEFENDANT'S EXHIBIT-H]

FIG. E.
[PAGE-4, 1930 CATALOGUE]
EXHIBIT - B.B.



or longitudinal flexibility as set forth in the Barnhart patents in suit.

Defendant does not use either the longitudinal slots of the Barnhart Patent No. 1,639,547 or the spiral slots of the Barnhart Patent No. 1,639,548. Within the interior of the hosel or ferrule of defendant's club there is no undercut providing a chamber within which the shaft is permitted to move to permit bending of the shaft or twisting thereof under a torsional strain. The construction of defendant's shaft as illustrated on page 4 of Plaintiff's Exhibit 8-B, Defendant's 1930 catalogue, shows that the hosel of the club is tapered from one end to the other: its smallest end being at the lower end of the tapered hole in the hosel or ferrule of the club head. The lower end of the shaft has a complementary taper. The shaft is driven into the hosel so that there is a tight fit maintained at all times between the hosel or ferrule of the club head and the shaft.

In order to insure the maintaining of this tight driven fit, a pin is driven through a hole positioned substantially midway between the ends of the ferrule of the club head, which pin passes through the shaft, tying the shaft in position and maintaining the driven metal to metal contact between the metal of the ferrule and metal of the shaft at all times. There can be no movement of the shaft within the hosel of the club head. The shaft is not secured at its extreme end to the ferrule or club head. No torsional twist of the shaft within the ferrule with relation to the shaft can occur in defendant's construction.

In order to ornament the club, a rubber bushing is inserted in a socket formed in the upper end of the ferrule and between the ferrule and the shaft. This rubber

bushing performs no function whatsoever in defendant's construction except possibly to protect the pyralin sleeve wrapped around the steel shaft at the lower end of this sleeve and likewise to ornament the appearance of the assembly. It does not reduce the breakage of the shafts and it has no other function. The shaft is secured tightly in position. Any bending of the shaft with relation to the ferrule occurs at the end of the driven fit between the tapered hosel and the tapered shaft. It is at this point where breakage occurs, except in cases of defective shaft construction.

The entire theory or principle upon which Barnhart predicates his claim to invention is lacking from defendant's structure as illustrated in Figure 4 of Defendant's 1930 catalogue, Plaintiff's Exhibit 8-B.

The Special Master's report, which was adopted by the District Court, is predicated upon an entirely erroneous theory of plaintiff's patents, their function and mode of operation, as set forth by Barnhart. The Special Master has construed in effect that the Barnhart patents in suit, both of them are for the flaring of the socket at the upper end of the hosel outwardly. With respect to this alleged feature of invention as construed by the Special Master, the Special Master in his report states:

“At first glance it would appear that the flaring of the outer portion of the socket would be an obvious way in which to distribute the strain at the point of juncture of the shaft and hosel.”

[Record, p. 154.]

With respect to the second patent in suit, and claim 10 thereof, the Special Master states:

“It appears that the claim should be limited to the use of a sealing member in a structure where the shaft and socket are relatively moveable in the manner disclosed by the patent.” [Record, p. 155.]

When thus construed, clearly this claim 10 is not infringed. The effect of the report of the Special Master is to construe both the Barnhart patents as directed toward the same purported invention, *i.e.*, the flaring of the socket at the upper end of the hosel outwardly.

In defendant's structure, and in both of defendant's structures, the shaft is a driven fit, a tapered shaft in a tapered hosel bore, wherein movement of the shaft with relation to the hosel is prevented. With the prevention of this movement of the shaft, the flaring of the upper end of the hosel can have no useful purpose as compared with the disclosure of the Barnhart patents in suit. In Figure F defendant endeavors to illustrate this fact. In one illustration of Figure F is shown the structure of the Barnhart patents. In the other illustration of Figure F defendant's club of the type shown on page 4 of defendant's 1930 catalogue, Plaintiff's Exhibit 8-B, is illustrated. The point here intended to be emphasized is that without the movement of that portion of the shaft within the hosel of the club head, the flaring of the outer end of the hosel or ferrule is of no effect. Without this freedom of movement of the shaft within the chamber formed in the interior of the elongated ferrule 2 of the Barnhart patent, there will always be a concentration of bending of the shaft at the point where the shaft fits tightly at the upper

end of the ferrule. In defendant's structure this point of concentrated movement of bending of the shaft is at the line marked "A" where the shaft emerges from the driven tapered fit. The flaring of the shaft above this line A can not and does not alter this fact. This fact is proven conclusively by the fact that defendant's clubs break at this point.

"With this club Defendant's Exhibit H and of this same construction, the Wilson Company has some difficulty with shaft breakage. In most cases the shaft breaks about a quarter of an inch below the top of the hosel. By the top of the hosel I mean the very uppermost end of the hosel, not the uppermost end of the undercut portion; the uppermost end of the hosel. That quarter of an inch would be just about down where that shoulder is; that is where it generally breaks." [Record, pp. 55-56.]

"* * * There can not be any movement of the end of that shaft as it is secured to the Defendant's Exhibit H or as secured in accordance with Plaintiff's Exhibit 3 within the hosel of the club to absorb that shock or any portion of it." [Record, p. 56.]

This point illustrated by the line A in the figure illustrating defendant's structure in Figure F, does not conform to, or in any way provide for, the function of the constricted portion 2^b of the Barnhart Patents Nos. 1,639,547 and 1,639,548 in suit. The point illustrated by the line A can not form, as does the constricted portion 2^b of the Barnhart patent, a pivot point over which the shaft has a gradual bend as that portion of the shaft within the hosel 2 bends as it does in the structures of the Barnhart patents in suit. Without the undercut open chamber 2^a as illustrated in the Barnhart patents in suit,

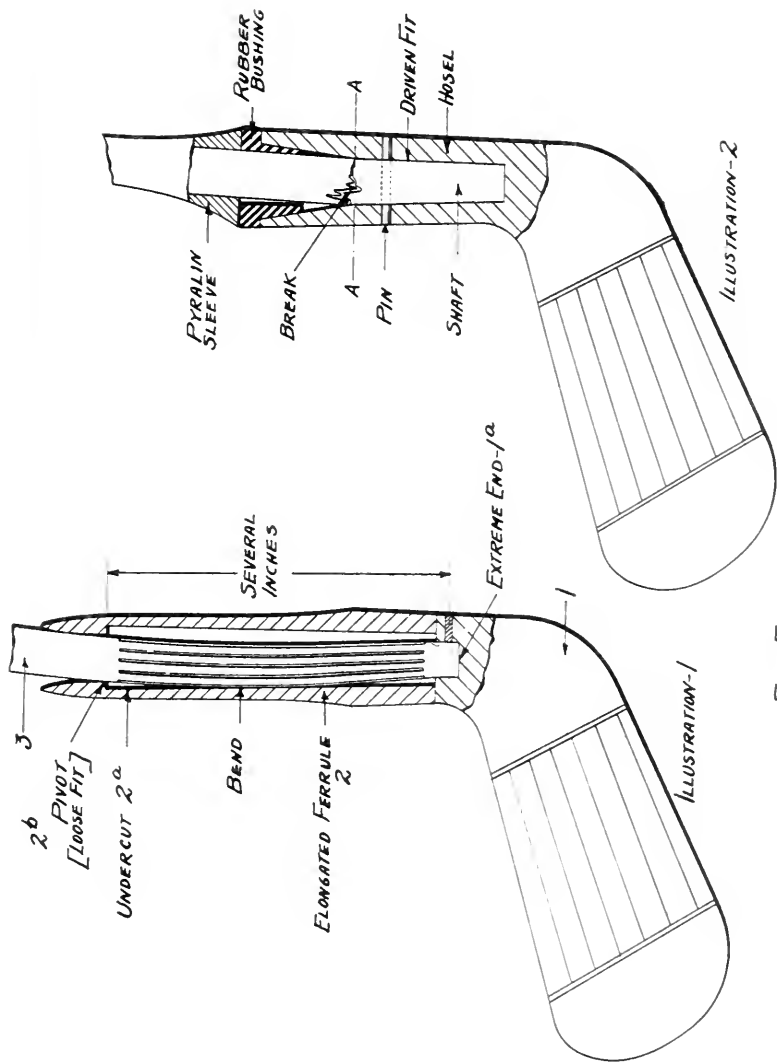

FIG. F.



the flaring of the upper end of the socket can be of no significance whatsoever. It is here that the Special Master erred in his construction of the Barnhart patents in suit. The Special Master erred in not realizing that without this undercut provision in the hosel or ferrule as illustrated in the Barnhart patent, there could be no pivotal movement of the shaft at the point illustrated at A or around a constricted portion of the hosel as called for in the Barnhart patents in suit. The Master erred in not seeing that a construction of the type utilized by defendant where there is a driven tapered fit could only result in concentration of bending of the shaft with relation to the ferrule of the golf club head at that point where the driven tapered fit between the tapered shaft and tapered bore of the hosel ends, that is, the point A. The Barnhart patent defines this constriction to be a means of providing a loose fit between the shaft and the ferrule for two purposes: one to provide a pivot point around which the shaft bends as the portion of the shaft within the interior of the hosel or long ferrule bends, and secondly, to provide a loose fit to permit the shaft to move inwardly into this chamber 2^a as the shaft in effect shortens due to the transverse bending or torsional twisting of the shaft within this chamber. It is evident from a consideration of defendant's structure that there can be no movement of the shaft within the tapered bore of the defendant's hosel. There is no loose fit provided for. There is no reason for such a loose fit. The entire function, purpose and mode of operation of defendant's structure is therefore the converse of the theoretical structure of the plaintiff's patents in suit.

Infringement is only made out where the supposed infringing structures operate through the same, or sub-

stantially the same, mode of operation; the same or substantially the same elements entering into that operation, and where those elements are combined or put together in the same manner. Identity of function, means and mode of operation is essential. Here there is no identity of means, identity of function, or identity of mode of operation. The essential element of the teaching of the Barnhart patents in suit is the constricted portion 2^b which provides a loose fit and a pivot over which the shaft bends with the freedom of movement of that portion of the shaft in the chamber 2^a of the elongated ferrule of the Barnhart patent in suit. This structure is entirely lacking in defendant's construction. In the case of *Heyl & Patterson v. M. A. Hanna Coal & Dock Co.*, 279 Fed. 862 at 864, the Court of Appeals for the Seventh Circuit said:

“We are of the view that a clamping device operating substantially in this manner is one of the essential and indispensable elements of the patented combination. This element we find wanting in appellee's device, in that the clamping action of the jaws is not effected by the weight there employed.”

As said by this court in *Riverside Heights Orange Grocers Association v. Stebler*, 240 Fed. 703. at 709-10, in holding non-infringement:

“But there is a further rule also applicable to this question, and that is:

“‘If the device of the respondents shows a substantially different mode of operation, even though the result of the operation of the machine remains the same, infringement is avoided.’ *Ciniotti Unhairing Co. v. American Fur Ref. Co.*, 198 U. S. 399, 414, 25 Sup. Ct. 697, 702 (49 L. Ed. 1100).”

Defendant's Second Structure.

Defendant's second structure is illustrated by Exhibit 3 and as to this structure, the Special Master found that it did not infringe any claim in suit of either of the Barnhart patents. As to this structure, the Master in his report stated:

“Exhibit 3, which the plaintiff offers as illustrating an alleged infringing structure differs from the club Exhibit 12 and the illustration in the 1930 catalogue. Instead of a gradually flaring taper at the upper end of the socket, this club has a portion cut away leaving a well defined shoulder below which the shaft is tightly fitted. There is little or no distribution of strain as the shaft is free to bend abruptly at this point. It is the function of the combination of the patent to avoid this action. It is concluded that none of the claims of the first patent in issue are infringed by clubs of the type of Exhibit 3. A rubber bushing is interposed between the shaft and the cut out portion of the socket. It is concluded that claim 10 of the second patent is not infringed in view of the previous finding that Claim 10 is limited to the use of a rubber bushing in combination with the particular hosel construction described in the patent.”

(Report of Special Master, Page 158.)

The construction of the club of Defendant's Exhibit 3 is illustrated by Figure G of this brief. As set forth by the Special Master, the construction of this club differs only from the club illustrated on page 4 of the 1930 catalogue, Exhibit 8-B, in that the recess at the upper end of the hosel has a straight wall W as illustrated in Figure G rather than the tapered wall illustrated in the construc-

tion of the club shown in Figure E. The club head has a hosel having a tapered bore into which the complementary tapered end section of the shaft is driven to form a driven fit. A pin P is driven through the shaft and the hosel to pin the shaft in position. A rubber bushing B is mounted in the recess in the upper end of the hosel between the hosel and the shaft. The function and purpose of this rubber bushing is to exclude dirt and moisture.

No appeal or cross appeal is taken with respect to the holding in the decree that this structure of Plaintiff's Exhibit 3 does not infringe any claim of the first Barnhart Patent No. 1,639,547. The cross appeal taken with respect to this structure seeks only a review of the Special Master's finding, and the court's decree, that this structure of club as illustrated by Plaintiff's Exhibit 3 does not infringe claim 10 of the second Barnhart Patent No. 1,639,548. The construction which plaintiff would place upon this claim 10 is that this claim 10 is a claim directed to use of a rubber bushing or washer for the purpose of excluding moisture and dirt. Any other construction placed upon claim 10 of the second Barnhart patent clearly shows that there is no infringement. With the claim construed as plaintiff desires to construe it, it is obvious that the claim defines no invention and is invalid. How at this stage of development of the art it can be considered by any one that invention resides in the use of a rubber washer to exclude moisture and dirt is beyond defendant's comprehension. Examination of the Barnhart Patent No. 1,639,548 shows that the Barnhart patent teaches that a wrapping or sleeve upon the outside of the hosel of the golf club and the outside of the shaft is equivalent to the use of a rubber washer within the recess formed between

the hosel and the shaft. In this Barnhart patent the illustration of the rubber moisture and dirt excluding member is of a sleeve 5 (Figure 6) which fits upon the exterior of the elongated ferrule 2 and around the shaft 3 at the point where the shaft 3 emerges from the elongated ferrule 2. This construction is particularly defined by Barnhart in his specification on page 2, lines 101-114, after which the specification of this second Barnhart patent includes the statement:

“It will be noted that a similar sleeve may be positioned around the joints of the ferrules and shafts shown in Figures 3, 4 and 5, or a cap, or washer may be positioned within the end of the ferrule around the shaft.”

(Barnhart Patent No. 1,639,548, p. 2, lines 116-119.)

The only function attributed to the rubber sleeve 5 is to exclude dirt, dust and grit from entering the ferrule and lodging between the same and the shaft, thus preventing proper coaction between the same. (Barnhart Patent No. 1,639,548, p. 2, lines 104-108.) What is meant in this portion of the specification by “coaction between the ferrule and the shaft” can only have reference to the movement permitted between the shaft and the hosel by the provision of the undercut chamber 2^a whereby freedom of movement of the portion of the shaft within this undercut chamber 2^a is provided for. Obviously if this chamber 2^a fills up with dirt, dust and grit it might so fill with these foreign matters as to prevent the free twisting of the shaft or the free bending of the shaft within this undercut chamber. If it was merely a driven fit as provided for in defendant’s structure, the

only result of admission of water, dirt or dust would be to prevent the free withdrawal of the shaft from the hosel when it is necessary or desirable to substitute a new shaft in the hosel of the club head. Even without any art which specifically illustrates the use of a rubber bushing for the exclusion of moisture, dust or grit, it is obvious that in the state of the arts as now developed that no invention could be involved. It was to these particular types of alleged changes that the Supreme Court of the United States referred when stating that "not every improvement in an article is patentable". *Burt v. Ivory*, 133 U. S. 349, 359.

Prior Patented Art.

The prior patented art relied upon by defendant shows conclusively that the Barnhart patents in suit are devoid of invention. These patents include the patents to

Robertson,	No. 206,264,	July 23, 1878,	Exhibit J-1
Kavanaugh,	No. 603,694,	May 10, 1898,	Exhibit J-2
Lard,	No. 1,249,127,	Dec. 4, 1917,	Exhibit J-3
Isham,	No. 1,435,851,	Nov. 14, 1922,	Exhibit J-4
Lagerblade,	No. 1,444,842,	Feb. 13, 1923,	Exhibit J-5
Treadway,	No. 1,531,632,	Mar. 31, 1925,	Exhibit J-6
Heller,	No. 1,551,563,	Sept. 1, 1925,	Exhibit J-7
Heller, Reissue	No. 16,808,	Dec. 6, 1927,	Exhibit J-8
Maas,	No. 1,553,867,	Sept. 15, 1925,	Exhibit J-9
Reach, et al.,	No. 1,601,770,	Oct. 5, 1926,	Exhibit J-10
Mattern,	No. 1,605,552,	Nov. 2, 1926,	Exhibit J-11
Pryde,	No. 1,615,232,	Jan. 25, 1927,	Exhibit J-12
British Pat. to	Saunders, No. 3288	of 1913,	Exhibit J-13

The claims alleged to be infringed are claims 11 and 12 of the Barnhart Patent No. 1,639,547, and claim 10

of the Barnhart Patent No. 1,639,548. These claims read:

11. In a golf club, a head member provided with a socket and with a shaft, the latter being secured at its one end within the inner portion of the socket, the portion of the shaft near the outer end of said socket being freely movable within and relative to and about the outer end portion of said socket to prevent buckling of said shaft at the outer end of the socket.

12. In a golf club, a head member provided with a socket and with a shaft, the latter being secured at its one end within the inner portion of the socket, the bore at the outer end of said socket being outwardly divergent forming a fulcrum about which said shaft is flexed longitudinally when striking a ball with the golf club.

10. In a golf club, a head having a socket, a shaft secured at one end within said socket, the portion of the shaft within the outer end of the socket being movable relative to the latter, and a flexible sealing member positioned at the joint between the outer end portion of said socket and said shaft.

The Barnhart patent in suit attempts to broadly cover a change which is not an improvement. Even if this change be considered to be an improvement, it is not an improvement rising to the dignity of invention. The Master in his report shows that he did not consider the question of invention, but considered this entire matter as a matter of abstract research without regard to the question of what is invention. The Master found that merely because the feature of flaring the upper end of the elongated ferrule is not in its identical shape shown in the prior art patents in its minutia, the patents and both

of them must be addressed to this feature, and that invention was therein embodied. In making this finding the Master of necessity did not consider the wording of the claims alleged to be infringed, the mode of operation ascribed to the structures disclosed in the patents in suit or whether or not that mode of operation was common to the defendant's structure.

Although neither claim 11 or 12 of the first Barnhart patent, nor claim 10 of the second Barnhart patent, is in any way directed to the flaring of the upper portion of the elongated ferrule, the Master concluded that this was the invention defined in these claims. The Master in his report states:

“At first glance it would appear that the flaring of the outer portion of the socket would be an obvious way in which to distribute the strain at the point of juncture of the shaft and hosel. However, an examination of the prior art patents does not disclose any suggestion of such a construction.”

[Report of Special Master, p. 154.]

In order to properly construe these claims asserted to be infringed both with reference to the showings made by the prior patented art and as to the question of infringement, it is necessary to consider these claims in the light of the specification of the Barnhart patents and likewise with respect to the representations made to the Patent Office with reference to these claims.

In the first Barnhart Patent No. 1,639,547, claims 11 and 12 were first submitted to the Examiner for his consideration in the amendment, Paper 3, dated January 14, 1927, Defendant's Exhibit D. These claims were sub-

mitted to the Commissioner of Patents as claims 16 and 17. With respect to these claims as they were added to the specification, Barnhart made the following representations to the Patent Office:

“The added claims 16 to 21, inclusive, have been drawn specifically to the construction of the ferrule, namely, to the pivot portion, or outwardly divergent portion at the outer end of the ferrule, and also to the under cut portion to permit flexion of the portion of the shaft within the ferrule.”

“Claim 16 defines the club as having a head member provided with a socket and with a shaft, the latter being secured at its one end and within the inner portion of the socket, the portion of the shaft near the outer end of the socket being freely movable within and relative to and about the outer end portion of the socket to prevent buckling of the shaft at the outer end of the socket. This is not shown, nor remotely suggested by the art cited.

“Claim 17 defines the ferrule as being outwardly divergent forming a fulcrum for the shaft. This also is not shown by the art of record.”

(Defendant's Exhibit D, Paper 3,
Amendment A, dated
January 14, 1927.)

As these claims were added, it is therefore represented to the Patent Office that the claims were directed to the combination of the pivot portion provided by the pivot 2^b and the undercut portion 2^a of the elongated ferrule 2

“to permit flexion of the portion of the shaft within the ferrule.”

(File wrapper, Exhibit D, *supra*.)

A fulcrum, the term applied to the pivot 2^b by Barnhart in this explanation of his invention, is an intermediate point on a lever around which the two opposing portions of the lever on opposite sides of the fulcrum may rotate. The intermediate rest of the board of a teeter-toter is such a fulcrum. A fulcrum as thus defined of necessity implies that the shaft 3 of the Barnhart patent has freedom of movement upon each side of the fulcrum. These representations made to the Patent Office and upon which the Patent Office granted the claims here involved can not be disregarded. The asserted mode of operation set forth to the Patent Office and upon which the allowance of these claims by the Patent Office was based can not be disregarded in the present construction of the claims in order that these claims may be interpreted to be infringed by the structure which does not employ said mode of operation.

Lorraine v. Townsend, 290 Fed. 54 (C. C. A. 9th Cir.);

Wilson & Willard Mfg. Co. v. Union Tool Co., 249 Fed. 729, 735 (C. C. A. 9th Cir.);

Warren Bros. Co. v. Thompson, 293 Fed. 745 (C. C. A. 9th Cir.);

Knick v. Bowes Co., 25 Fed. (2d) 442 (C. C. A. 8th Cir.);

White v. Dunbar, 119 U. S. 47, 52;

Hennebique Const. Co. v. Urban Co., 182 Fed. 496, 498 (C. C. A. 8th Cir.);

George E. Lee Co. v. Fortified Mfg. Co., 284 Fed. 315, (C. C. A. 8th Cir.);

I. T. S. Rubber Co. v. Essex Co., 272 U. S. 429, 443, 71 L. Ed. 335, 342;

Niblo Mfg. Co. v. Prcston, 39 Fed. (2d) 604 (C. C. A. 2nd Cir.);

Quick Action Ignition Co. v. Maytag Co., 39 Fed. (2d) 595, 597 (C. C. A. 8th Cir.).

“* * * an express statement in a claim, which is in accord with the specifications and drawings, can not be construed to mean something different, nor can it be reconstructed so as to eliminate the limitations indicated in the specifications and drawings and shown by the literal meaning of the claim * * *.”

Newa-Slip Shirt Waist Grip Co. v. Marcon Co., 215 Fed. 117.

In *Stuebing Truck Co. v. Olson*, 291 Fed. 63, at 66 (C. C. A. 7th Cir.), the court says:

“The patent was obtained upon the representation that the structure was so constructed as to ‘force the operator to gain control of the load at all times, before raising or lowering the load.’ We have not deemed it necessary to refer to the prior art to confirm this conclusion, because the patent and the file wrapper are so conclusive as to require no such corroboration.”

In *Douchian v. Kingston*, 138 Fed. 895, it is said:

“It would be unjust to the public, and to all the parties involved in the construction of the patent if a patentee were allowed to ‘understandingly and deliberately’ limit the scope of his patent while he is obtaining it, and were afterwards allowed to escape from his limitation when the patent is construed. He ought not to be heard to demand one rule of interpretation in the Patent Office and another in the

courts. The ordinary principles relating to the interpretation of a contract are the principles which prevail in construing a patent. The understanding of parties to an agreement at the time it is made is always held to be of importance in the construction of such agreement. Courts often find aid in construing a contract by considering what the parties have said and what they have done when the contract was made.”

As said by the Circuit Court of Appeals of the Sixth Circuit in *Dowagiac Mfg. Co. v. Superior Drill Co.*, 115 Fed. 886, at end of 896:

“* * * whatever doubt there might have been as to whether the claim was limited in the construction of its language by the specification, *it was removed by the limitation which he put upon it by his explanation*, the consequence of which was the allowance of his patent; *and the claim must be read as limited in this respect* in the same way as are the other claims.” (Italics ours.)

As said by this Court in *Hauser v. Simplex Window Co.*, 10 Fed. (2d) 457, at 460:

“The art is quite old, and it was to avoid references that the applicant limited the claim to a structure with a friction shoe contiguous to the corner of the sash; and, having limited his claim in order to obtain his patent, he is not now in a position to claim a construction that he might have had if limitations and restrictions were not in the claims. *Computing Scale Co. v. Automatic Scale Co.*, 27 S. Ct. 307, 204 U. S. 609, 51 L. Ed. 645; *Fullerton Walnut Growers' Association v. Anderson-Barngrover Mfg. Co.*, 166

F. 443, 92 C. C. A. 295; *Selectasine Patents v. Prest-o-graph Co. (C. C. A.)*, 282 F. 223. We must, therefore, look upon claim 1 as limited to a structure wherein the frictional element is a yieldably mounted shoe placed in the upper end of the sash contiguous to the corner thereof, and engaging slidably the guide in the upper part of the frame. Nor do we regard Hauser's pivot as equivalent to Soule's friction shoe. While the two devices use frictional means in obtaining the ultimate result, they do not operate in substantially the same manner."

Barnhart did not invent the use of a steel shaft in a golf club. This was not invention, but even if it were, Barnhart admits that this was old prior to his alleged inventions. The first Barnhart Patent No. 1,639,547, says:

"In golf clubs now in use, the shafts are made of wood as well as of steel tubing."

(Barnhart Patent No. 1,639,547, p. 1, lines 4-5.)

Barnhart did not invent the placing of the shaft end into a bore formed in the hosel or ferrule of the club head. The patents to Lard, No. 1,249,127, Exhibit J-3, Book of Exhibits, page 38; Robertson, No. 206,264, Exhibit J-1, Book of Exhibits, page 31, and each of Exhibits J-5 to J-13, inclusive, illustrate this method of inserting the shaft end into the bore of the club head hosel.

Barnhart did not invent the making of the shaft movable at the outer end of the socket into which the club head is fitted. The patent to Lard, No. 1,249,127, Exhibit J-3, Book of Exhibits, pages 37 to 42, discloses this movability of the shaft at the outer end of the socket for

the purpose of absorbing strains and reducing localization of the strain in the shaft at this point. As said by Lard in his specification, page 2, lines 83-93:

“A neck constructed by the use of washers or the like absorbs, to a certain extent, or degree, any tendency for the shaft to break at its point of entrance into the tubular socket member. Furthermore, such washers tend in a great measure, to prevent moisture from getting into and around the socket. When rubbed down and shellacked, the leather washers become substantially water-proof, and in fact they may be waterproofed before being positioned.”

The patent to Isham, No. 1,435,851, Exhibit J-4, Book of Exhibits, pages 44-47, inclusive, illustrates the manner of securing a handle or shaft 2 to a head 1 by interposing between the shaft 2 and the head 1 a rubber sleeve 4^a so that a yielding movement is permitted between the shaft 2 and the head 1 within the rubber lined socket.

The patents to Heller, No. 1,551,563, Exhibit J-7, and the Reissue patent to Heller, No. 16,808, Exhibit J-8, Book of Exhibits, pages 57-63, inclusive, illustrate the connection of a tapered golf shaft 4 and the hosel 5 of the club 3 by forcing the tapered shaft through a sleeve of rubber 7, which rubber 7 fills the cavity or chamber provided between the bore of the hosel 5 and the exterior of the shaft 4. The rubber sleeve 7 extends above the flared upper end of the hosel of the golf club head 3 and as set forth particularly in the Reissue Patent No. 16,808, this construction provides for the desired vertical torsional or horizontal displacement under impact of the shaft 4 with reference to the club head 3. Heller in his Reissue Patent No. 16,808, page 1, lines 31-43, states:

“The improved construction and mounting of the head upon the shaft thus afforded provides for additional resiliency at the region of the lower end of the shaft and is particularly desirable in its association with a hollow steel shaft as illustrated. In the latter use there is introduced an advantageous elastic rebound of the head portion relative to the shaft from both vertical and torsional or horizontal displacement under impact, this torsional resiliency being to a large degree lacking in steel shaft clubs at present used.”

The sleeve 7 is of rubber as set forth by Heller :

“In the preferred embodiment of my invention, the resilient or rubber sleeve 7 is of suitable thickness to provide, upon forcing of the shaft within the bore,
* * *” (Heller Reissue Patent No. 16,808,
p. 1, lines 88-91.)

The sleeve 7 extends beyond the upper end of the flared portion of the hosel and when thus extended, prevents the admission of water, dirt, grit, dust, or other foreign matter into the hosel 5 of the club head 3.

“The resilient sleeve is here illustrated at 7 and extends from the lower end of the bore upwardly for the full length of the bore and projects for a small distance therebeyond.”

(Heller Reissue Patent No. 16,808,
p. 1, lines 77-81.)

The patent to Pryde, *et al.*, No. 1,615,232, Exhibit J-12, Book of Exhibits, pages 79-81, inclusive, illustrates the securing of a tapered shaft into the tapered bore of the hosel of a golf club head 18 by means of pins or rivets 19 passed through the hosel and through the tapered shaft 10.

Interposed between the tapered shaft 10 and the inner bore of the hosel is a rubber sleeve 11 which, as set forth by Pryde, may extend the entire length of the shaft 10 or not, as desired. Pryde's object, as set forth in his specification, is:

“Our invention is designed to overcome these and other objections to the metal shaft golf club. This desirable end is accomplished by encircling the tubular metal shaft with an outer shell of vulcanized rubber which has a less degree of flexibility than the tubular metal shaft. Thus we have found by experiment, that in a shaft constructed in the manner indicated that the force of the blow or impact against the ball is absorbed in the shaft and does not reach the hands of the player but is mellowed or blended in very much the same manner as in a shaft constructed of wood.”

(Pryde, *et al.*, Patent No. 1,615,232,
p. 1, lines 41-49.)

The rubber sleeve illustrated by Pryde, *et al.*, likewise eliminates the necessity of windings at the joint between the hosel of the club head and the shaft, and obviously acts to prevent the admission of moisture, dust, dirt or grit into the hosel of the club head. Pryde, *et al.*, state:

“The shell 11 is also enlarged at 20 to form a shoulder 21, which abuts against the upper face of the metal head and forms a rigid joint therebetween, thus obviating the necessity of a wooden shell, as heretofore, and the necessary waxed winding cord therefor, thus a very strong joint is made between the shaft and the head without adding any material weight to the club.”

(Pryde, *et al.*, Patent No. 1,615,232,
p. 2, lines 7-15.)

The Robertson Patent No. 206,264, of July 23, 1878, Exhibit J-1, Book of Exhibits, pages 31-33, inclusive, illustrates the manner of securing a shaft A to a head or handle B in such a manner as to distribute the strain and prevent localization of the strain of bending or twisting at the point of emergence of the shaft A from the head B. As is true of the Barnhart patents, Robertson illustrates his head as undercut at C and provides a yieldable fulcrum means at G. The shaft A is secured to the head B at its extreme end E. Thus the strains of bending and twisting are distributed over the length of the shaft and not concentrated at the point of emergence of the shaft A from the head B. The yieldable member G as illustrated by Robertson is formed of India rubber and of the characteristics of bending of the shaft A, Robertson states:

“The bore or inclosure *c* is of larger diameter in its center than at its ends—that is to say, is elliptical in shape—in order that when the piece *a* is bent into a curved form by the strain upon the rod this curve shall extend from end to end, as the bore of the handle *b* is sufficiently large to permit of this.”

(Robertson Patent No. 206,264, p. 1,
last paragraph of column 1.)

The prior art patents illustrate that each and every claimed feature of the Barnhart patents was old and common in the art long prior to Barnhart's alleged invention, and unless therefore we disregard, (as is necessary in order to construe these claims to be infringed by defendant's structures, or either of them,) the necessary limitations of the claims asserted to be infringed, these claims are invalid. Even considering these claims in their most limited character, they are clearly devoid of inven-

tion in view of the teachings of these prior art patents of the same manner of mounting a club head and shaft to obtain the same results asserted to be obtained by Barnhart through the use of his theoretical structure disclosed in the patents in suit.

Barnhart did not invent, as is shown by these prior art patents, the connecting of a club shaft and head by a driven fit where the club head is pinned to the shaft to prevent the driven fit loosening. He did not invent the provision of a means such as a rubber washer or sleeve at the point of the emergence of the club shaft from the hosel of the club head to either absorb shock, distribute the strain, or to prevent the admission of moisture, dirt, dust or grit into the hosel of the club head around the shaft. Both the patents to Lard, No. 1,249,127, Exhibit J-3, and the patent to Robertson, No. 206,264, Exhibit J-1, illustrate each of these features in a single construction. As set forth by the Supreme Court in *Atlantic Works v. Brady*, 107 U. S. 192, 27 L. Ed. 438, 440:

“The process of development in manufactures creates a constant demand for new appliances, which the skill of ordinary head workmen and engineers is generally adequate to devise, and which, indeed, are the natural and proper outgrowth of such development. Each step forward prepares the way for the next, and each is usually taken by spontaneous trials and attempts in a hundred different places. To grant to a single party a monopoly of every slight advance made, except where the exercise of invention, somewhat above ordinary mechanical or engineering skill, is distinctly shown, is unjust in principle and injurious in its consequences.

“The design of the patent laws is to reward those who make some substantial discovery or invention, which adds to our knowledge and makes a step in advance in the useful arts. Such inventors are worthy of all favor. It was never the object of those laws to grant a monopoly for every trifling device, every shadow of a shade of an idea, which would naturally and spontaneously occur to any skilled mechanic or operator in the ordinary progress of manufactures. Such an indiscriminate creation of exclusive privileges tends rather to obstruct than to stimulate invention. It creates a class of speculative schemers who make it their business to watch the advancing wave of improvement, and gather its foam in the form of patented monopolies, which enable them to lay a heavy tax upon the industry of the country, without contributing anything to the real advancement of the arts. It embarrasses the honest pursuit of business with fears and apprehensions of concealed liens and unknown liabilities to lawsuits and vexatious accountings for profits made in good faith.”

As said in *Smith v. Nichols*, 21 Wall. 112, 119, 22 L. Ed. 566, and cited with approval by this Court in *D. J. Murray Co. v. Sumner I. Works*, 300 Fed. 911, 912:

“But a mere carrying forward or new or more extended application of the original thought, a change only in form, proportions, or degree, the substitution of equivalents, doing substantially the same thing in the same way by substantially the same means with better results, is not such invention as will sustain a patent.”

Defendant's clubs do not infringe. Claims 11 and 12 of the Barnhart Patent No. 1,639,547, even if construed to be valid, can not be construed to be infringed by defendant's club of the form illustrated on page 4 of Plaintiff's Exhibit 8-B, or as illustrated in Figure F hereto. A claim of a patent must be construed as found and it is contrary to the settled rule of Patent Law to imply as elements of a claim parts not therein designated for the purpose of according novelty to the claims or for the purpose of construing the claims to be infringed. Chief Justice Taft, while Circuit Judge, in speaking for the Court of Appeals for the Sixth Circuit in *Frederick R. Stearns & Co. v. Russell*, 85 Fed. 218, 224, says:

“To imply as elements of a claim parts not named therein for the purpose of limiting its scope, so that it may be accorded novelty, is contrary to a well-settled rule of the patent law. It was proposed to limit a claim thus in *McCarty v. Railroad Co.*, 160 U. S. 110, 116, 16 Sup. Ct. 240. The patent there under consideration was for a car truck bolster. Mr. Justice Brown, in delivering judgment for the supreme court, said (page 116):

“There is no suggestion in either of these claims that the ends of the bolster rest upon springs in the side trusses, although they are described in the specification and exhibited in the drawings. It is suggested, however, that this feature may be read into the claims for the purpose of sustaining the patent. While this may be done with a view of showing the connection in which a device is used, and proving that it is an operative device, we know of no principle of law which would authorize us to read into a claim an element which is not present, for the purpose of making out a case of novelty or infringe-

ment. The difficulty is that if we once begin to include elements not mentioned in the claim in order to limit such claim, and avoid a defense of anticipation, we should never know where to stop. If, for example, a prior device were produced exhibiting the combination of these claims plus the springs, the patentee might insist upon reading some other element into the claims, such, for instance, as the side frames and all the other operative portions of the mechanism constituting the car truck, to prove that the prior device was not an anticipation. It might also require us to read into the fourth claim the flanges and pillars described in the third. This doctrine is too obviously untenable to require argument.’”

As said in *Great Western Co. v. Lowe*, 13 Fed. (2d) 880, at 884, in applying this rule that a patentee is bound by his claims as written, and the court cannot read limitations into them to save them from anticipation:

“If an inventor were permitted to obtain broad claims, and thereafter write in such limitations as are necessary to avoid the prior art, but still cover an alleged infringing structure, the public would never be certain as to the meaning of a claim, and endless confusion and litigation would result.”

The Special Master, contrary to this established rule, read into claim 11 of the first Barnhart Patent No. 1,639,547, and claim 10 of the second Barnhart Patent No. 1,639,548, the limitations that the upper end of the socket is flared outwardly:

“As before noted the claims of the first patent in issue are limited to the flared end portion of the

socket which functions to lessen the strain on the shaft at the point of juncture with the hosel. * * * The claim of the second patent in issue is directed to the combination of a flexible bushing and the flared socket without regard to the slotted shaft.”

[Report of Special Master, p. 154.]

Claim 11 does not in any of its terms call for the socket being flared outwardly. Claim 10 does not in any of its terms call for the socket being flared outwardly. The Special Master correctly construes these claims as being anticipated without this limitation, and even with the limitation, states that it is doubtful as to whether these claims define patentable novelty. [Special Master’s Report, Record, p. 154.]

Claims 11 and 12 of the first patent as heretofore pointed out were allowed by the Commissioner of Patents upon the argument made by Barnhart that these claims were limited to the securing of the shaft at its one end within the socket formed in the hosel of the club, and the provision of the pivot or fulcrum means at the opposite end of the hosel wherein the shaft is permitted to bend in the undercut portion 2^a of the elongated ferrule 2. The Special Master disregarded the positive limitations of claims 11 and 12 in this respect in order to construe the claims to be infringed by defendant’s structure as illustrated in Figure E hereof, and as illustrated on page 4 of the catalogue, Plaintiff’s Exhibit 8-B. Claim 11 calls for the shaft being secured at its one end within the inner portion of the socket. As set forth in the specifications of the Barnhart patent, this means the extreme end. The extreme end is in some point positioned several inches up the length of the shaft away from the extreme end. It

was pointed out to the Examiner in the allowance of this claim that the word "socket" as employed in this claim referred to the under cut portion 2^a as illustrated in the drawings of this Barnhart patent. When these claims were presented to the Patent Office they were presented with the statement that they were drawn specifically to the construction of the ferrule and

"also to the under cut portion to permit flexion of the portion of the shaft within the ferrule."

The Special Master in construing this claim to be infringed, entirely disregarded this express limitation of claim 11. Further, the Special Master in construing claim 11 to be infringed disregarded that latter portion of the claim which requires that the shaft is so movable about the pivot or restricted portion of the socket as to prevent buckling of the shaft at the outer end of the socket. The evidence clearly establishes that this is the particular point where the shafts of defendant's clubs broke. The defendant's structure, therefore, does not have that mode of operation as required by claim 11 of preventing buckling of the shaft at the outer end of the socket.

Claim 12, in addition to including the limitations set forth in connection with claim 11, defines that the structure of the Barnhart patent includes a fulcrum about which the shaft is flexed when striking a ball with a golf club. A fulcrum is defined:

"2. mech. The support, as a wedge-shaped piece or a hinge, about which a lever turns."

(Webster's New International
Dictionary.)

Its simple illustration is, as hereinabove set forth, the support upon which the board of a teeter-toter rotates. As used in connection with claim 12, and in connection with the disclosure made in the Barnhart patent, it means the point around which the shaft rotates as the portion of the shaft within the undercut 2^a bends as illustrated in the illustration of this Barnhart structure in Figure F. It has no significance whatsoever unless it is construed in connection with the illustration of the bending of the shaft 3 within the under cut 2^a. Further than this, the claim 12 specifically calls for the fulcrum being the point about which the shaft 3 flexes when the club head strikes a ball. It is necessary to totally disregard this limitation of claim 12 as well as the representations made to the Patent Office with respect to what claim 12 was intended to define in order to hold that claim 12 is infringed by the structure of club illustrated on page 4 of the 1930 catalogue, Plaintiff's Exhibit 8-B.

Claim 10 of the second Barnhart patent defines that the shaft is secured at its end within the socket. It is necessary to disregard this definite limitation of this claim in order to conclude that this claim is infringed by defendant's structure. It is necessary to disregard what is meant by these terms as set forth in the specification of the Barnhart patent in order to conclude that the defendant's structure of Plaintiff's Exhibit 3 infringes this claim. The specifications of the second Barnhart Patent No. 1,639,548, leave no room to question what is meant by this expression wherein the specification states:

“The small end of the shaft is positioned within the ferrule and the extreme end of the reduced portion is secured to the shank end of the head to which the ferrule is connected.”

(Barnhart Patent No. 1,649,548, p. 1,
line 110, to p. 2, line 2.)

It will be impossible to more definitely define this point of connection of the shaft and head than was done by Barnhart. The extreme end of the shaft not only means the absolute shaft end, but is also set forth as being the point at which the elongated ferrule 2 is secured to the club head 1, *i. e.*, the extreme end of the ferrule 2. As illustrated in Figure 4, this is the point beyond the undercut 2^a of the ferrule 2 and below the weakened portion of the shaft formed by the formation of the helical or spiral slots 3^a.

Contrary to the limitations of the claims as hereinabove set forth, the defendant's structures include a tapered shaft driven into a tapered bore and pinned into position, forming one of the most positive forms of connection known to mechanics. No movement is permitted or can take place between the shaft and the hosel of the club head within such a tapered driven fit. As is common to all clubs, the shaft therefore bends at the point where the shaft emerges from the tapered fit. The strain of bending is localized at this point with the result that breakage of the shafts in defendant's structures occurs at this point. There is therefore no similarity in means or the instrumentalities used in making the connections between the

shaft and the club head and as compared between the illustration of plaintiff's patent and defendant's structures. There is no fulcruming or bending of a lever over a fulcrum; there is no free movement of the shaft within the undercut chamber of a hosel; the shaft is not weakened within the hosel to permit of greater torsional or longitudinal flexibility of the shaft, and the shaft is not secured at its one end to the club head in order to permit of this bending or flexing of the club to distribute the strain at the point of emergence of the shaft from the hosel of the club head. The mode of operation set forth for the club of the Barnhart patent is not found in the defendant's structures, or either of them. The asserted function performed through the use of the instrumentality set out in connection with the Barnhart patent is not attained through the use of defendant's clubs.

The rule of law applicable to the question of infringement as applied by this Honorable Court in *Eaid v. Trovohy Bros. Co.*, 230 Fed. 444, is:

“Being a mere improvement on the prior art, McConnell is only entitled to the precise devices described and claimed in his patent, and if the devices embodied in the Chandler patent can be differentiated, it is clear that the charge of infringement cannot be maintained. Such is the well-established law. *Kokomo Fence Machine Co. v. Kitzelman*, 189 U. S. 8, 23 Sup. Ct. 521, 47 L. Ed. 689; *Boyd v. Janesville Hay Toll Co.*, 158 U. S. 260, 15 Sup. Ct. 837, 39 L. Ed. 973; *Railway Co. v. Sayles*, 97 U. S. 554, 24 L. Ed. 1053; *McCormick v. Talcott*, 20 How. 402, 15 L. Ed. 930.”

Conclusion.

Appellant and cross-appellee therefore submits:

1. That the respective claims of the Barnhart patents in suit relied upon are void because each of them is anticipated.
2. That the respective claims of the Barnhart patents in suit relied upon are void as not defining invention.
3. That there is no infringement. The defendant's clubs do not embody the same combination of elements having the same mode of operation or functioning in the same manner as is inherent in the structures disclosed in the Barnhart patents in suit, and therefore there can be no infringement.

Appellant and cross-appellee therefore submits that this Court should pronounce the claims of the Barnhart patents in suit to be void and that the structures of the golf clubs as manufactured by defendant do not infringe.

Respectfully submitted,

LYON & LYON,

LEWIS E. LYON,

Attorneys for Appellant and Cross-Appellee



In the United States
Circuit Court of Appeals
For the Ninth Circuit.

Wilson-Western Sporting Goods Co.,
a corporation,

Appellant and Cross-Appellee,

vs.

George E. Barnhart,

Cross-Appellant and Appellee.

CROSS-APPELLANT'S BRIEF.

FRANK L. A. GRAHAM,
Subway Terminal Bldg. 417 S. Hill St., L. A.,
Attorney for Plaintiff, Cross-Appellant.



TOPICAL INDEX.

	PAGE
Statement of the Case.....	3
Assignments of Error.....	5
Patents in Suit.....	5
Validity	8
Argument	9
Point I. It is plaintiff's contention that the golf club exemplified by Plaintiff's Exhibit No. 3 is an infringement of Claim 10 of the Barnhart Patent No. 1,639,548.....	9
Diagram	12
Conclusion	15



No. 7807.

In the United States
Circuit Court of Appeals
For the Ninth Circuit.

Wilson-Western Sporting Goods Co.,
a corporation,

Appellant and Cross-Appellee,

vs.

George E. Barnhart,

Cross-Appellant and Appellee.

CROSS-APPELLANT'S BRIEF.

STATEMENT OF THE CASE.

This is a suit in Equity brought for infringement of Letters Patent No. 1,639,547 and No. 1,639,548, both issued on the 16th day of August, 1927. Both patents concern inventions in golf clubs and particularly with the manner of attaching a tapered hollow steel shaft to the head of the club.

Plaintiff in the suit is George E. Barnhart, of Pasadena, California, who, while not in the business of manufacturing and selling golf clubs, has been engaged for a number of years in the production of improvements relating to tapered drawn steel shafts and the manner of securing such shafts to the heads of golf clubs.

The defendant, Wilson-Western Sporting Goods Co., is a corporation of the state of Maine and is one of the largest manufacturers and distributors of golf clubs and sporting goods in the United States.

The suit was referred to David B. Head, as Special Master, who, in his report [Tr. p. 148] found both of the Letters Patent in suit good and valid in law and claims 11 and 12 of Letters Patent No. 1,639,547 and claim 10 of Letters Patent No. 1,639,548, infringed by defendant by the sale and offering for sale of one type of golf club shown in defendant's 1930 Catalogue and Exhibit 12.

The Master also found that the defendant had not infringed either of the Letters Patents in suit by the selling and offering for sale of another type of golf clubs of the construction shown in Exhibit 3.

Both plaintiff and defendant took exceptions to the Master's report and after oral argument the report was confirmed by the Hon. Paul J. McCormick, District Judge for the Southern District of California, Central Division.

By stipulation the Master's report was adopted as Findings of Fact and Conclusions of Law. [Tr. p. 163.]

Defendant presented a motion for a Bill of Particulars and before filing its Bill of Particulars the defendant, upon written request of plaintiff (Book of Exhibits p. 22), furnished plaintiff with copies of its catalogues entitled "The Gateway to Golf" for the years 1929 to 1933 inclusive.

Upon being furnished with the catalogues, just referred to, plaintiff filed its Bill of Particulars [Tr. p. 13] and among other things charged infringement of the patents in suit by the golf club illustrated on page 4 of the 1930 edition of the "Gateway to Golf," (Book of Exhibits p. 17), the golf club illustrated on page 5 of the 1931 issue of the "Gateway to Golf," (Book of Exhibits p. 19) and also the golf clubs illustrated on certain designated pages of the 1932 and 1933 issue of the "Gateway to Golf."

The clubs found to infringe claims 11 and 12 of the first patent and claim 10 of the second patent are those illustrated in the 1930 issue of the "Gateway to Golf" just referred to. (Exhibit 8-B, Book of Exhibits p. 17 and Exhibit 12.)

Assignments of Error.

The assignments of error relied on by plaintiff in its Cross-Appeal [Tr. p. 180], read as follows:

"(1) In finding and decreeing that claim 10 of United States Letters Patent No. 1,639,548 is not infringed by defendant's golf clubs as shown in Plaintiff's Exhibit No. 3.

(2) In failing to find and decree that defendant's golf clubs as shown in Plaintiff's Exhibit No. 3 infringe claim 10 of Letters Patent No. 1,639,548."

Patents in Suit.

Patent No. 1,639,547, herein referred to as the first patent in suit, points out that at the time of the application, to-wit, October 14, 1926, the golf clubs then in use were provided with either wooden shafts or those made of

steel tubing, that although the golf clubs with wooden shafts provided flexibility and resiliency both longitudinally and torsionally, the shafts of such clubs break frequently at the portions where the shaft enters the head and that although the steel shafts were more durable such shafts also break frequently at the portions secured to the heads.

In the form of the invention illustrated in this patent [Tr. p. 2] it is to be noted that the bore of the upper end of the hosel or socket (referred to in the patent as a ferrule) is flared outwardly so that the extreme upper end of the hosel does not fit tightly about the shaft and it is this particular feature which permits the shaft at the outer end of the hosel or socket to move within the end of the hosel. It is also this feature which permits a gradual bending of the shaft within the end of the hosel, as distinguished from the common form in which the shaft bends over a sharp end of the hosel, and to which claims 11 and 12 of this patent are directed. These claims read as follows:

“11. In a golf club, a head member provided with a socket and with a shaft, the latter being secured at its one end within the inner portion of the socket, the portion of the shaft near the outer end of said socket being freely movable within and relative to and about the outer end portion of said socket to prevent buckling of said shaft at the outer end of the socket.

12. In a golf club, a head member provided with a socket and with a shaft, the latter being secured at its one end within the inner portion of the socket, the bore at the outer end of said socket being outwardly divergent forming a fulcrum about which said shaft is flexed longitudinally when striking a ball with the golf club.”

In the second patent in suit, to-wit, No. 1,639,548, claim 10 held to be infringed by the club illustrated in the 1930 edition of the "Gateway to Golf" is drawn to the same general features as claims 11 and 12 in the first patent but with the additional feature of the inclusion of a bushing placed within the outer end of the hosel and between the hosel and the shaft.

Claim 10 of the second patent reads as follows:

"10. In a golf club, a head having a socket, a shaft secured at one end within said socket, the portion of the shaft within the outer end of the socket being movable relative to the latter, and a flexible sealing member positioned at the joint between the outer end portion of said socket and said shaft."

On page 2 of the second patent (Book of Exhibits, p. 10, line 101), a flexible cap such as shown in Fig. 6 of the drawings (Book of Exhibits p. 8) is described as for the purpose of—

"excluding dirt, dust and grit from entering the ferrule and lodging between the same and the shaft and thus preventing proper co-action between the same."

also—

"Thus, the shaft is permitted to flex, twist and expand relative to the ferrule and still exclude dirt, dust and grit therefrom. It will be noted that a similar sleeve may be positioned around the joints of the ferrules and shafts shown in Figures 3, 4 and 5, *or a cap, or washer may be positioned within the end of the ferrule around the shaft.*" (Italics ours.)

It is this particular construction of a hosel having a flared or wide mouth which permits the shaft to bend within the end of the hosel against a resilient member or cushion to which claim 10 of the second patent is directed.

Validity.

The Master, in his Findings [Tr. p. 154), stated that—
“the claims of the first patent in issue are limited to the flared end portion of the socket which functions to lessen the strain on the shaft at the point of juncture with the hosel.”

and that—

“The claim of the second patent in issue is directed to the combination of a flexible bushing and the flared socket without regard to the slotted shaft.”

He also stated:

“At first glance it would appear that the flaring of the outer portion of the socket would be an obvious way in which to distribute the strain at the point of juncture of the shaft and hosel. However, an examination of the prior art patents does not disclose any suggestion of such a construction. This tends to strengthen the presumption of invention.”

The Master then concluded that claims 11 and 12 of the first patent, together with claims 13 and 15 of that patent were valid. With respect to claim 10 of the second patent the Master stated as follows [Tr. p. 155]:

“Claim 10 of the second patent was allowed without comment by the Patent Office: Other claims drawn to the construction of Figure 6 were rejected. The patent to Lard, Exhibit J-3, was not cited. The function of the washers in Lard and the bushing of the patent is the same, *i. e.*, to exclude dirt from the socket. However, the relative movement between the shaft and socket in the structure of the patent is not found in the Lard club. The patentee’s problem was to provide a sealing means which was sufficiently

flexible to permit this movement. The presumption of validity has not been rebutted and it is concluded that the claim is valid. It appears that the claim should be limited to the use of a sealing member in a structure where the shaft and socket are relatively movable in the manner disclosed by the patent.”

It is this claim 10 of the second patent that is involved in this Cross-Appeal, insofar as the Master found this claim not infringed by the particular golf club marketed by defendant, shown by Exhibit 3.

ARGUMENT.

POINT I.

It Is Plaintiff's Contention That the Golf Club Exemplified by Plaintiff's Exhibit No. 3, Is an Infringement of Claim 10 of the Barnhart Patent No. 1,639,548.

The particular question before this Court on the Cross-Appeal can best be illustrated by comparing the construction of the club found not to infringe claim 10 of the second patent with the structure illustrated in Exhibit 8-B (Book of Exhibits p. 17) found to infringe that claim.

The illustration on this page shows the upper portion of the hosel cut away thereby illustrating the internal structure of the hosel at that point. It will be noted that the steel shaft extends into the hosel and that the lower end engages the inner walls of the hosel at that portion marked "close frictional fit" from that point upwardly the inner walls of the hosel flare outwardly forming a space between the shaft and the flared walls

of the hosel, marked on the illustration "chamber." Seated on the upper end of the hosel and extending downwardly into the chamber is a bushing formed of specially treated rubber, marked on the illustration "rubber bushing." The shaft is further secured in the hosel by means of a rivet marked on the illustration "anchoring."

The only difference between this structure which the lower court held to infringe claims 11 and 12 of the first patent and claim 10 of the second patent is in the shape of the inner wall of the hosel at the part marked "chamber" in the illustration. In the club held not to infringe (Plaintiff's Exhibit 3) the inner wall of the hosel is not flared outwardly as shown in the illustration in the Book of Exhibits p. 17, but the "close frictional fit" extends upwardly to the lower end of the rubber bushing, at which point a shoulder is formed leaving a space between the hosel and shaft in which the rubber bushing is seated.

The record shows that there was evidence, pro and con, about the advantages of the patented construction but while the defendants lavishly praised the prior art patents the reading matter opposite the illustrations on page 17 of the Book of Exhibits is a record made by the defendant of what it thought of the invention as long ago as the year 1930. This printed statement by defendant reads as follows:

"Outstanding among Wilson features for golf club improvement is the new 'no shock' development. This feature forstalls any possibility of shock, at the

time of impact, being transmitted from the club head through the shaft. This invention is so ingeniously worked out that it is possible to obtain this freedom from shock and still have the shaft actually anchored to the club head. This makes it absolutely impossible for the club head to turn upon the shaft. The illustration clearly gives you the story of this scientific improvement. Note that the lower end of the shaft is secured to the hosel not only by a frictional contact but also by a metal rivet running clear through the shaft and hosel, which prevents all possibility of turning. Then note that the hosel spreads out in a manner similar to the type of hosel used for wooden shafts and that into the space thus created between the shaft and upper hosel is inserted a bushing of specially treated rubber. This rubber bushing acts as a shock insulator and also allows a slight independence of movement between the hosel and shaft which results in the much desired effect of torsion found in the finest wooden shafts.

These improvements are unique and will be found in clubs built by no other manufacturer. Experts have acclaimed them as being the most valued improvement ever brought to steel shafted irons."

At the trial of this case defendant offered evidence to show that its structure did not include "a shaft secured at one end within said socket," that by reason of the fact that the rivet passing through the hosel or socket in the shaft therein part way up the socket that shaft was not secured at one end. In this connection the reading matter in the catalogue above referred to was contrary

to defendant's contention at the trial as it plainly states that—

“the *lower end* of the shaft is secured to the hosel not only by a frictional contact but also by a metal rivet running clear through the shaft and hosel, which prevents all possibility of turning.” (Italics ours.)

It may be true that Fig. 5 of the second patent in suit (Book of Exhibits p. 8) shows a rivet closer to the lower end of the shaft than defendant places its rivet, but in both instances the *lower end* of the shaft is secured by such means in the hosel.

It is plaintiff's contention that whether the inner wall of the hosel is flared outwardly at the top, which form was held to infringe claim 10, or whether the hosel has a shoulder formed therein near the top as in Exhibit 3, that in both forms the shaft within the outer end of the socket is movable relative to the socket, that the rubber cushion or bushing prevents the shaft from bending too abruptly over the shoulder whereby the common breaking of the shaft is minimized, and that both forms infringe claim 10 of the second patent in suit.

On the following page herein is illustrated the construction of the club shown on page 17 of the Book of Exhibits held to infringe claim 10 of the second patent in suit, and the construction of the club typified by Exhibit 3 held not to infringe that claim. Plaintiff submits that these illustrations demonstrate that both constructions infringe claim 10 of the second patent in suit.

CLAIM 10.

In a golf club,

- (a) a head having a socket,
- (b) a shaft
- (c) secured at one end within said socket,
- (d) the portion of the shaft within the outer end of the socket being movable relative to the latter, and
- (e) a flexible sealing member positioned at the joint between the outer end portion of said socket and said shaft.

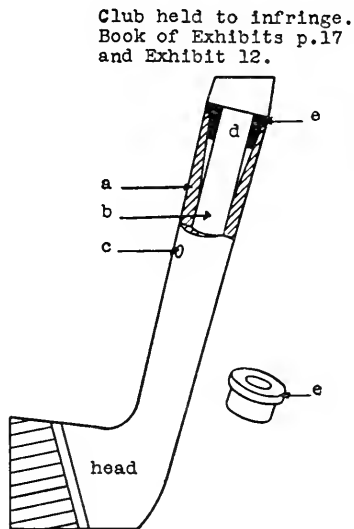

CLAIM 10.

In a golf club,

- (a) a head having a socket,
- (b) a shaft
- (c) secured at one end within said socket,
- (d) the portion of the shaft within the outer end of the socket being movable relative to the latter, and
- (e) a flexible sealing member positioned at the joint between the outer end portion of said socket and said shaft.

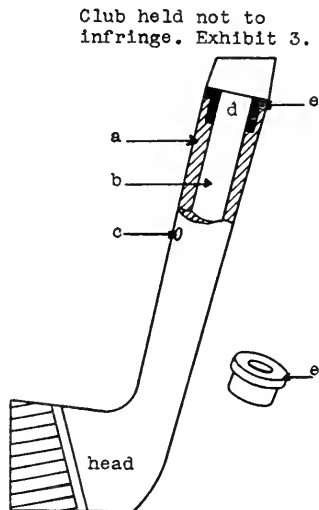



In both forms shown on the preceding page the end of the socket is cut away on the inside to permit "the portion of the shaft within the outer end of the socket" to be "movable relative to the latter."

Each construction includes the "flexible sealing member positioned in the joint between the outer end portion of said socket and said shaft" as called for in the claim.

The Master in his report [Tr. p. 155] stated:

"It appears that the claim should be limited to the use of a sealing member in a structure where the shaft and socket are relatively moveable in the manner disclosed by the patent."

It is true that the patent shows the inner bore of the hosel or socket as flared outwardly, but it is plaintiff's contention that whether the inner bore is flared outwardly identically as shown in the patent or whether it is formed with a step as shown in Exhibit 3, both the flared inner bore and the stepped inner bore provide a space between the hosel and the shaft which permits "the shaft within the outer end of the socket being moveable relative to the latter" as called for in claim 10, and that the flexible bushing interposed in the end of the hosel between the hosel and the shaft performs the same function in both cases.

It needs no citation of authority to show that Exhibit 3 is an infringement of the claim and this court is well aware of the rule that the simplicity or obviousness of a thing does not negative invention.

Claim 10 reads directly on Exhibit 3 and it is plaintiff's contention that the structure of the club, Exhibit 3, is clearly an equivalent of the structure of the patent and of the structure of the club held to infringe. Mr. Justice Clifford in *Union Paper Bag Machine Co. v. Murphy*, 97 U. S. 120, 125, 24 L. Ed. 935, stated as follows:

“Except where form is of the essence of the invention, it has but little weight in the decision of such an issue, the correct rule being that, in determining the question of infringement, the court or jury, as the case may be, are not to judge about similarities or differences by the names of things, but are to look at the machines or their several devices or elements in the light of what they do, or what office or function they perform, and how they perform it, and to find that one thing is substantially the same as another, if it performs substantially the same function in substantially the same way to obtain the same result; always bearing in mind that devices in a patented machine are different in the sense of the patent law when they perform different functions or in a different way, or produce a substantially different result.”

The question of novelty and utility may well be disposed of in the words of the Special Master [Tr. p. 155]:

“The defendant's adoption of the features of the patents here in issue is a use which tends to strengthen the presumptions of novelty and utility. *Hallock v. Davison*, 107 F. 482; *Kelsey Heating Co. v. James Spear etc. Co.*, 155 F. 976.”

Conclusion.

It is finally submitted that the golf club, Exhibit 3, is an infringement of claim 10 of Letters Patent No. 1,639,548 and that the interlocutory decree heretofore entered herein should be modified to so decree.

Respectfully submitted,

FRANK L. A. GRAHAM,
Attorney for Plaintiff, Cross-Appellant.



In the United States
Circuit Court of Appeals
For the Ninth Circuit.

Wilson-Western Sporting Goods Co.,
a corporation,

Appellant and Cross-Appellee,

vs.

George E. Barnhart,

Cross-Appellant and Appellee.

BRIEF FOR APPELLEE AND CROSS-
APPELLANT.

FRANK L. A. GRAHAM,

Subway Terminal Bldg., 417 S. Hill St., L. A.,

Attorney for Appellee, Cross-Appellant.

FILED
OCT 21 1935



TOPICAL INDEX.

	PAGE
Statement of the Case.....	3
Argument	6
Point I. The claim in issue of each of the patents in suit are valid as embracing patentable inventions.....	6
Point II. Defendant's type of club exemplified by the illustration in the 1930 edition of "The Gateway to Golf" (Book of Exhibits, p. 17, also Exhibit 12) infringe claims 11 and 12 of the first Barnhart patent and claim 10 of the second Barnhart patent.....	16
Conclusion	20

TABLE OF AUTHORITIES CITED.

CASES.

General Electric Co. v. Wagner Electric Mfg. Co., 130 Fed. 772	14
Griswold v. Harker, 62 Fed. 389.....	15
Hallock v. Davidson, 107 Fed. 482.....	13
Kelsey Heating Co. v. James Spear Stove & Heating Co., 155 Fed. 976.....	14
Sandy MacGregor v. Vaco Grip Co., 2 Fed. (2d) 655.....	19



No. 7807.

In the United States
Circuit Court of Appeals
For the Ninth Circuit.

Wilson-Western Sporting Goods Co.,
a corporation,

Appellant and Cross-Appellee,

vs.

George E. Barnhart,

Cross-Appellant and Appellee.

**BRIEF FOR APPELLEE AND CROSS-
APPELLANT.**

STATEMENT OF THE CASE.

In this brief plaintiff-appellee will attempt to limit the discussion to matters pertinent to defendant's appeal and not the cross-appeal.

The facts relating to the proceedings in this suit have been fully stated at the beginning of our brief, filed on behalf of cross-appellant, but an abbreviated statement may be made as follows:

This is a suit in equity brought for infringement of Letters Patent No. 1,639,547 and No. 1,639,548, both

issued on the 16th day of August, 1927, to George E. Barnhart. Both patents relate to golf clubs and the claims involved in this appeal particularly refer to the manner of attaching a tapered hollow steel shaft to the head of the club.

The suit was referred to David B. Head as Special Master, who, in his report [Tr. 149] found both of the Letters Patent in suit good and valid in law and claims 11 and 12 of Letters Patent No. 1,639,547 and claim 10 of Letters Patent No. 1,639,548 infringed by defendant, by the sale and offering for sale of one type of golf club shown in defendant's 1930 catalogue, Exhibit 8-B and Exhibit 12. The Master also found that a certain Exhibit 3, did not infringe the said claims.

Exceptions were taken by both plaintiff and defendant to the Master's report and after oral argument the report was confirmed by the Hon. Paul J. McCormick, District Judge for the Southern District of California, Central Division. By stipulation the Master's report was adopted as Findings of Fact and Conclusions of Law. [Tr. 163.]

Defendant presented a motion for a bill of particulars and before filing its bill of particulars the defendant, upon written request of plaintiff (Book of Exhibits, p. 22), furnished plaintiff with copies of its catalogues entitled "The Gateway to Golf" for the years 1929 to 1933, inclusive.

Upon being furnished with the catalogues, just referred to, plaintiff filed its bill of particulars [Tr. p. 13] and

among other things charged infringement of the patents in suit by the golf club illustrated on page 4 of the 1930 edition of "The Gateway to Golf" (Book of Exhibits, p. 17), the golf club illustrated on page 5 of the 1931 issue of "The Gateway to Golf," (Book of Exhibits p. 19) and also the golf clubs illustrated on certain designated pages of the 1932 and 1933 issue of "The Gateway to Golf".

The clubs found to infringe claims 11 and 12 of the first patent and claim 10 of the second patent are those illustrated in the 1930 issue of "The Gateway to Golf" just referred to (Exhibit 8-B, Book of Exhibits, p. 17, and Exhibit 12).

The cross-appeal, by plaintiff, is from the finding of non-infringement of claim 10 of Letters Patent No. 1,639,548, by the golf club exemplified by Exhibit 3.

Appellant's brief is written in such a manner that it is not clear as to just what points the argument is directed, but by a reference to appellant's "conclusion" on page 49 of its brief, it appears that generally, appellant is asking this court to pronounce the claims of the Barnhart patent in suit to be void, first, because they are "anticipated," second, "as not defining invention," and, third, "that there is no infringement" for the reason that "defendant's clubs do not embody the same combination of elements having the same mode of operation or functioning in the same manner as is inherent in the structures disclosed in the Barnhart patents in suit."

ARGUMENT.

POINT I.

The Claim in Issue of Each of the Patents in Suit Are Valid as Embracing Patentable Inventions.

Appellant in its discussion of the patents in suit, beginning with page 6 of its brief, attempts to cloud the issues by repeatedly referring to disclosures in the patents which are not pertinent to an understanding of the invention covered by the respective claims herein involved. We particularly refer to the many references made by appellant in those portions of appellant's brief which discuss the matters particularly illustrated on pages 6a and 6b of that brief, particularly the slotted portion of the shaft and its associated parts including the chamber referred to on the two pages as the "under cut" portion of the hosel. It is a well known rule of patent law that each claim of a patent is considered as setting forth a complete and independent invention. The Master in his report [Tr. p. 157] clearly states the rule in the following words:

"Defendant's contention that the patents are limited to a structure wherein the elements of the claims in issue are used in combination with the undercut socket and slotted shaft does not appear to be well taken. The Patent Office allowed claims including all of the elements described as well as the claims in issue which do not include the undercut socket and the slotted shaft. Again referring to Figure 4 of the first patent, a construction is found wherein the undercut socket and slotted shaft are not used. Claims drawn to subcombinations of elements are

good provided that invention is present in the combination. The claims, being valid, can not be limited by reading additional elements into them.”

The court’s attention is called to claims 11 and 12 of patent No. 1,639,547 held to be infringed, which claims read as follows:

“11. In a golf club, a head member provided with a socket and with a shaft, the latter being secured at its one end within the inner portion of the socket, the portion of the shaft near the outer end of said socket being freely movable within and relative to and about the outer end portion of said socket to prevent buckling of said shaft at the outer end of the socket.

12. In a golf club, a head member provided with a socket and with a shaft, the latter being secured at its one end within the inner portion of the socket, the bore at the outer end of said socket being outwardly divergent forming a fulcrum about which said shaft is flexed longitudinally when striking a ball with the golf club.”

The physical elements in claim 11 are a “head member” having a socket, a shaft secured at “its one end”, the portion of the shaft near the outer end of the socket being “freely movable within and relative to and about the end portion of the socket.” Claim 12 is similar to claim 11 except that the claim defines the outer end of the socket as “being outwardly divergent.”

It will therefore be noted that these claims are not directed to that portion of the disclosures of the patent relating to a shaft that is slotted or to a hosel that is under cut to form a chamber in the hosel coincident with

the slotted portion of the shaft. In other words, these claims are each directed to inventions separate and distinct from those inventions defined in other claims. Several of the other claims refer particularly to these other features, as an example, claim 5, which is particularly directed to the slotted shaft feature.

A reference to Figure 4 of patent No. 1,639,457, hereinafter referred to as the "first patent," shows that this slotted feature so much emphasized by appellant is lacking in the form there illustrated but in both forms illustrated the internal bore at the upper end of the socket is flared outwardly to permit the shaft near the outer end of the socket to be freely movable therein as stated in claim 11 and is particularly that portion of the invention referred to in claim 12 wherein it states that "the outer end of the socket is outwardly divergent."

Appellant in its brief lays great emphasis on that portion of the first patent referring to the objects sought by the inventor and to the use therein of language stating that the shaft is secured at its "extreme end" to the head of the shaft. Attention is called to the fact that the claims do not say "extreme end" but state that the shaft is secured "at its one end." In the first patent on page 2, beginning with line 79, the inventor states with reference to Figure 4, that

"the inner end of the shaft may be secured, if desired, to the head member in any suitable manner."

and later says, beginning with line 102 on the same page, that he does not

"wish to be limited to this particular construction, combination and arrangement, nor to the modifications, but desire to include in the scope of my in-

vention the construction, combination and arrangement substantially as set forth in the appended claims.”

Consequently, in view of the fact that the claim does not say “at the extreme end” but says at “one end” the limitation sought by appellant cannot properly be read in the claim.

In both of defendant’s structures, charged to infringe, the shaft is secured in the head by means of a rivet such as disclosed in Fig. 5 of patent No. 1,639,548, hereinafter referred to as the “second patent,” and in connection with the point at which this rivet is placed in the shaft plaintiff’s own witness [Tr. p. 59], Mr. Horace E. Gillette, stated:

“The function of the rivet in holding the hosel on the shaft is the same whether it was in the identical spot shown in Defendant’s Exhibit H or whether it was lower or higher on the shaft.”

The exhibit just referred to was one produced by defendant and apparently taken from the shelves of the defendant company at the time of the hearing, being substantially like plaintiff’s Exhibit 3.

Mr. William A. Doble, defendant’s expert witness [Tr. p. 108, beginning on the last line], stated:

“Of course, to put a pin through you have to come back far enough to have metal to get it through.”

In other words, the rivet would be through “one end” of the shaft as called for in the claims. The same remarks apply with equal force to the claim involved in the second Barnhart patent, which reads as follows:

“10. In a golf club, a head having a socket, a shaft secured at one end within said socket, the portion of the shaft within the outer end of the socket being movable relative to the latter, and a flexible sealing member positioned at the joint between the outer end portion of said socket and said shaft.”

The reference in the claim to securing the shaft at “one end” according to the specification may be done in any manner to suit conditions. This is stated in the specification, beginning at line 3, on page 2, where it is stated:

“The method of securing the end of the shaft to the head may vary to suit conditions.”

That portion of the claim referring to the shaft within the outer end of the socket being movable relative to the socket is particularly explained on page 2, beginning with line 75, where it states:

“The bores at the outer ends of the ferrules, in Figs. 3 and 4, are tapered outwardly in curved form so as to permit greater longitudinal flexion of the shaft relative to the ferrule.”

(The ferrule referred to in the patent has been referred to throughout the case as the hosel.) Reference to this structure of the hosel, is also found on page 2 of the second patent, beginning with line 93.

The other elements in this claim, that is, the “flexible sealing member,” is particularly referred to, beginning with line 112, on page 2 of the second patent in suit, and particularly lines 117 to 119, where it states:

“or a cap, or washer may be positioned within the end of the ferrule around the shaft.”

Referring to page 1 of the second Barnhart patent among the objects pointed out by the inventor this feature of the shaft being movable in the end of the hosel is particularly referred to beginning with line 45 in the following words:

“seventh, to provide a golf club having a shaft-positioning socket, on its head and a shaft mounted with one end within the socket and shiftable relative to the outer end of the latter, said socket being so constructed as to prevent buckling of the shaft at or near the outer end of the socket,”

The invention to which claim 10 in this patent is directed is to a structure wherein the slots are included or *not included*.

With reference to the “flexible sealing member” in claim 10 which has been referred to throughout the case as a rubber gasket or bushing, appellant, beginning with the third from the last line on page 19 of its brief, states that the rubber bushing is merely for the purpose of ornamenting the club. This statement reads as follows:

“In order to ornament the club, a rubber bushing is inserted in a socket formed in the upper end of the ferrule, and between the ferrule and the shaft. This rubber bushing performs no function whatsoever in defendant’s construction except possibly to protect the pyralin sleeve wrapped around the steel shaft at the lower end of this sleeve and likewise to ornament the appearance of the assembly.”

Regardless of whether appellant did in fact consider a rubber bushing ornamental, plaintiff’s expert, Doble [Tr. p. 103], in discussing the prior art patents, particularly Exhibit J-10, admitted that a bushing made of

“fiberloid” would have the effect of “reducing shock,” and with reference to a rubber sleeve, disclosed in defendant’s Exhibits J-7 and J-8 that it would be “More so, as it is much more resilient than is the fiberloid.” In the quotation from appellant’s brief, just above, appellant also claims that the bushing “performs no function whatsoever in defendant’s construction except possibly to protect the pyralin sleeve.” Mr. Gillette, plaintiff’s own witness, states on page 59 of the transcript: “I don’t think the portion of the rubber that extends down between the hosel and the shaft protects the pyrolyene collar.” Mr. Gillette goes on to say that he did not think that the rubber extending down between the shaft and hosel performs any function, and then immediately after states:

“If we left the rubber out of there, the shaft would bend directly over that edge, without any resistance in the end of the hosel.”

In plaintiff’s brief on cross-appeal, beginning near the end of page 10, is quoted at length a statement appearing on page 17 of the Book of Exhibits, made by appellant in its yearly catalogue called “The Gateway to Golf” for the year 1930. In this statement appellant gives its own definition of the structure of its club and not only states, that

“this invention is so ingeniously worked out that it is possible to obtain this freedom from shock and still have the shaft actually anchored to the club head.”

but also places appellant’s own interpretation on what is meant by the “lower end” of the shaft, when it states

“note that the lower end of the shaft is secured to the hosel not only by a frictional contact but also by

a metal rivet running clear through the shaft and hosel.”

This statement also refers to the upper end of the hosel being shaped to receive “a bushing of specially treated rubber,” and gives the functioning of the rubber bushing in the following words:

“This rubber bushing acts as a shock insulator and also allows a slight independence of movement between the hosel and shaft which results in the much desired effect of torsion found in the finest wooden shafts.”;

in other words, the particular thing that Barnhart, the patentee, was seeking as pointed out on page 1 of the first patent in suit, lines 18 to 23. The full statement, in the catalogue referred to appears in plaintiff’s Exhibit 8-B (Book of Exhibits, p. 17).

The fact that defendant (appellant) adopted and is using the invention set forth in the claims in issue is sufficient in itself to overcome any attacks which may be made by defendant on the patentability of the inventions covered by such claims. Many cases have considered this question, among which are the following:

In the case of *Hallock v. Davidson*, 107 F. 482, the court stated as follows:

“The defendants have themselves contributed to the cogent testimony establishing the excellence of the weeder by copying it in every essential detail. This being the general situation the court is naturally disinclined to relax the rule which makes the patent prima facie evidence of its validity and casts the burden of showing the contrary upon the defendants. *Cantrell v. Wallick*, 117 U. S. 689, 695. 6 Sup. Ct. 970, 29 L. Ed. 1017.”

In the case of *Kelsey Heating Co. v. James Spear Stove & Heating Co.*, 155 F. 976-979, it is stated:

“* * * Affirming as they thus do, in the most pronounced way possible, to its superior merits and their own inability to do better, they cannot well complain if the inventive originality which is claimed for it is held to sufficiently appear.”

At this point it may be mentioned that appellants produced in evidence some 13 prior patents but with respect to these patents the Master stated as follows [Tr. 154]:

“At first glance it would appear that the flaring of the outer portion of the socket would be an obvious way in which to distribute the strain at the point of juncture of the shaft and hosel. However, an examination of the prior art patents does not disclose any suggestion of such a construction. This tends to strengthen the presumption of invention.”

It is this portion of the Master's report that appellant on the first page of its brief only quotes in part. The finding of the Master, just above quoted, is amply supported by appellant's own expert, Doble, as appears on pages 114 and 115 of the transcript.

As stated in the case of *General Electric Co. v. Wagner Electric Mfg. Co.*, 130 F. 772-778:

“The failure of defendants to avail themselves of said earlier devices or improve them, and their bodily appropriation of the patented construction, is most persuasive upon the question of invention.”

Also in the case of *Griswold v. Harker*, 62 F. 389-393, it is stated:

“Actions often speak louder, and frequently more truthfully, than words. It is not impossible that the reason why the appellees are not using the old devices they plead is that the improvements described in this patent have made them useless and unmerchantable. If this is not so, they can abandon the improvements of Selden and Griswold, and go back to the devices they plead.”

Appellant would have us believe that the defendant (appellant) has discontinued clubs like those shown in plaintiff's Exhibit 8-B (1930 catalogue) and Exhibit 3 and gives as an excuse that the breakage was so great as to render the construction impractical, but the evidence clearly shows that the defendant is still selling clubs having the infringing construction referred to, even in what has been referred to as the “Oggmented” club which was first introduced the latter part of 1933 and which was on the market in 1934. Defendant, however, since the suit was brought in its endeavor to find something to take the place of the invention of the claims in suit is also now selling a club having what is called a Croyden shaft, an expensive shaft formed with a bulge in the shaft right above the end of the hosel. However, appellant admitted by its witness Flynn [Tr. p. 67] that the “rubber no-shock” (the infringing club) sold at a higher price than the old style club and that, “The no-shock that I refer to is the rubber collar that is inserted on the shaft.”

POINT II.

Defendant's Type of Club Exemplified by the Illustration in the 1930 Edition of "The Gateway to Golf" (Book of Exhibits, p. 17, Also Exhibit 12) Infringe Claims 11 and 12 of the First Barnhart Patent and Claim 10 of the Second Barnhart Patent.

In view of the fact that plaintiff's (appellee's) charge of infringement of the club designated with plaintiff's Exhibit 3 is fully discussed in the brief filed on behalf of the cross-appellant (plaintiff) herein, appellee will confine the discussion to the question of infringement insofar as it concerns the type of club shown in the 1930 catalogue and Exhibit 12.

As the club shown in the 1930 catalogue is of the same construction as Exhibit 12 we will refer to page 17, of the Book of Exhibits, as illustrating the structure held to infringe. The Master, in his report which has been adopted as findings of fact [Tr. p. 156] describes the infringing club in the following language:

"The shaft is closely fitted in the lower part of the socket and held in place by a pin at about the middle part of the socket. The socket is flared outward at the upper end. This permits the shaft to flex above the closely fitted portion without bending over a sharp edge. A rubber bushing is fitted around the shaft, a portion of the bushing extending down between the shaft and hosel."

The Master then found claims 11 and 12 of the first patent and claim 10 of the second patent infringed by this construction, just above referred to.

Claims 11 and 12 of the first Barnhart patent read as follows:

“11. In a golf club, a head member provided with a socket and with a shaft, the latter being secured at its one end within the inner portion of the socket, the portion of the shaft near the outer end of said socket being freely movable within and relative to and about the outer end portion of said socket to prevent buckling of said shaft at the outer end of the socket.

12. In a golf club, a head member provided with a socket and with a shaft, the latter being secured at its one end within the inner portion of the socket, the bore at the outer end of said socket being outwardly divergent forming a fulcrum about which said shaft is flexed longitudinally when striking a ball with the golf club.”

By reference to the illustration on page 17 of the Book of Exhibits, it will be noticed that the club is provided with a head member having a socket with a shaft in the socket, that the shaft is secured “at its one end” within the inner portion of the socket (see the rivet marked “anchoring” in the illustration) that the shaft near the outer end of the socket is freely movable within and relative to and about the outer end portion of the socket (part in the illustration marked “chamber” permits this movement). Claim 12 is substantially the same except it is limited by describing the outer end of the socket as being outwardly divergent which appears in the illustration as within the walls of the socket forming the “chamber.” In discussing these claims the rubber bushing may be disregarded. Not only is the structure the same as called for in the claims but the function of the parts

is also the same. Not only can this be seen from the illustration but the descriptive matter beside the illustration clearly removes any doubt on these questions. In view of the length of the argument by appellant offering that the shaft is not secured "at one end," the descriptive matter by the illustration states "Note that the *lower end of the shaft* is secured to the hosel," etc. (Italics ours.)

Certainly it is not necessary to quote law to this court in a case where infringement is as clear as here, particularly when the claims read directly on the infringing structure and the infringing structure accomplishes the same purpose and performs the same function in doing so.

Claim 10 of the second Barnhart patent reads as follows:

"10. In a golf club, a head having a socket, a shaft secured at one end within said socket, the portion of the shaft within the outer end of the socket being movable relative to the latter, and a flexible, sealing member positioned at the joint between the outer end portion of said socket and said shaft."

With respect to claim 10, of the second patent in suit, and using the same illustration on page 17, of the Book of Exhibits, the additional feature in the claim over claims 11 and 12, of the first patent, is "a flexible sealing member positioned at the joint between the outer end portion of said socket and said shaft." this is the part marked "rubber bushing" in the illustration which is the identical thing called for in the claim.

Attention is called to the fact that the patents in suit both issued on the same day and that the invention covered by claim 10 of the second patent in suit in fact is the addition of one element, to-wit, the rubber bushing to the

combination set forth in claims 11 and 12 of the first patent. This situation was passed on by the Circuit Court of Appeals for the Second Circuit in the case of *Sandy MacGregor v. Vaco Grip Co.*, 2 F. 2nd. 655 (which case referred to a golf practicing and exercising device), in the following language:

“It seems to us to be beyond dispute, upon the principles involved, that, if the combination a b c when first made by the patentee was invention, and if the addition of the element d adds utility, even though of itself it would not involve invention if compared with the earlier invention of a b c by some one else, yet the patentee is entitled to claims upon a b c and upon a b c d, and the validity of the second claim may rest, in part, upon its inclusion of the invention more broadly stated in a b c. Most naturally these claims would appear as generic and specific in the same patent: but, if the rules of the Patent Office require, or if the patentee desires and the rules of the Patent Office permit, the issue of separate patents to the same inventor, and they are issued the same day, it cannot be said that the one which bears the earlier application date or issue number is part of the prior art as against the other one always assuming that “prior art” is a matter not touching dedication or double patenting. This was the conclusion we reached upon a discussion of the authorities in *Higgin Co. v. Watson*, 263 F. 378, 385.”

This claim 10 of the second Barnhart patent is clearly infringed for the same reasons as pointed out in connection with claims 11 and 12 of the first Barnhart patent.

Conclusion.

The appellee (plaintiff) insofar as defendant's appeal is concerned, submits:

(1) That claims 11 and 12 of the first patent in suit and claim 10 of the second patent in suit are valid as for a patentable invention, and

(2) That such claims are infringed by the structure of defendant's club illustrated in "The Gateway to Golf", Plaintiff's Exhibit 8-B and Exhibit 12.

It is therefore submitted that this court should find infringement of claims 11 and 12 of the first Barnhart patent and claim 10 of the second Barnhart patent and affirm the interlocutory decree herein in that respect, and that with respect to plaintiff's cross-appeal separately submitted by cross-appellant's brief, filed herein, the decree be modified by finding infringement of the said claims by defendant's golf club, Exhibit 3.

Respectfully submitted,

FRANK L. A. GRAHAM,
Attorney for Appellee, Cross-Appellant.

In the United States
Circuit Court of Appeals
For the Ninth Circuit.

Wilson-Western Sporting Goods Co.,
a corporation,

Appellant and Cross-Appellee,

vs.

George E. Barnhart,

Cross-Appellant and Appellee.

PETITION FOR REHEARING.

FRANK L. A. GRAHAM,
Subway Terminal Bldg., 417 S. Hill St., L. A.,

Attorney for Appellee.

FILED

1938

PAUL P. GIBBEN

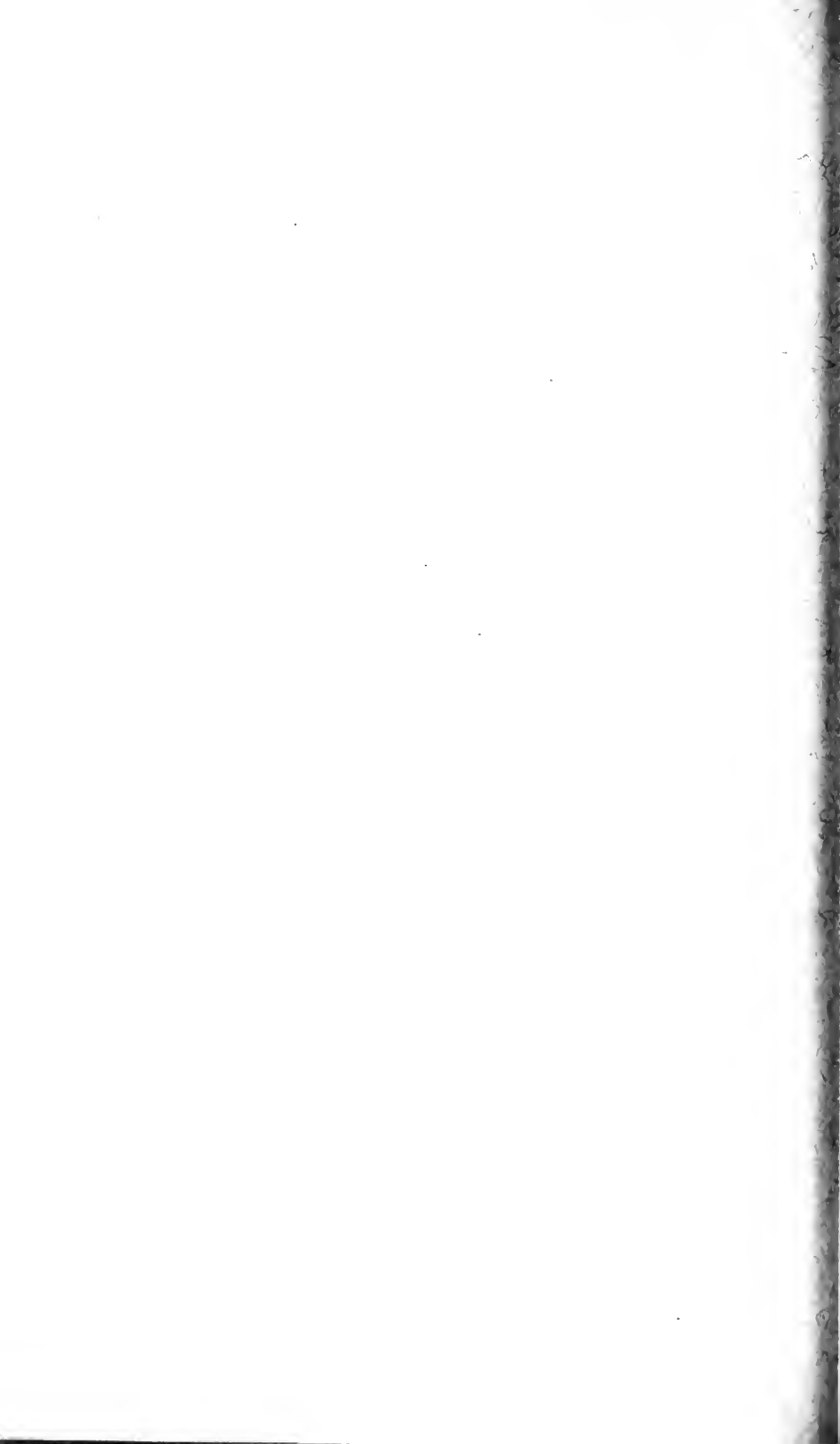

No. 7807.

In the United States
Circuit Court of Appeals
For the Ninth Circuit.

Wilson-Western Sporting Goods Co.,
a corporation,
Appellant and Cross-Appellee,
vs.
George E. Barnhart,
Cross-Appellant and Appellee.

PETITION FOR REHEARING.

*To the Honorable Judges of the United States Circuit
Court of Appeals:*

Now comes the appellee, George E. Barnhart, by his attorney and moves this Honorable Court for a rehearing herein, first, on the ground that this Court, in conflict with its own prior decisions of *Smith v. Howland*, 11 F. (2d) pp. 9-13, *Stoody v. Mills Alloys*, 67 F. (2d) 807, and the Supreme Court cases of *Furrer v. Ferris*, 145 U. S. p. 133, 36 L. Ed. pp. 649-651, and *Davis v. Schwartz*, 155 U. S. 631, 39 L. Ed. 289-293, found that with respect to the Master's Findings that "the report of the Master is entitled to little if any weight in this court," and

Secondly, on the ground that this Court erroneously found claims 11 and 12 of the first Barnhart patent and

claim 10 of the second Barnhart patent void as lacking invention.

With respect to the first point, mentioned above, this Court quoted at length from the case of *Kimberly v. Arms*, 129 U. S. 512, 523-524. In the instant case the Order of Reference [Tr. pp. 27-28] provided that the Master—

“take and hear the evidence offered by the respective parties and to make his conclusions as to the facts in issue and recommend the judgment to be entered thereon; the said Special Master DAVID B. HEAD is authorized and empowered to do all things and to make such orders as may be required to accomplish a full hearing on all matters of fact and law in issue in this cause, reserving to the Court the full right and power to review and determine all questions of fact and law upon exceptions to the report of said Special Master by the respective parties, as fully and completely had this reference not been made and as though this cause had been tried before the Court; the objection of counsel for the defendant to the making of this order referring the cause to the Master is hereby noted, and an exception is allowed in favor of the defendant.”

After the Master filed his report, both plaintiff and defendant filed exceptions to the Master's report. [Tr. pp. 160-162.] It is true that the Master's report by stipulation was adopted as Findings of Fact and Conclusions of Law, but this was done only after the Court heard the case upon the exceptions to the Master's report and after the Court had considered the pleadings and proof and argument by both parties as appears in the preamble to the decree on page 164 of the transcript. In other words

the District Court in this case, as pointed out on page 4, of appellant's brief, overruled the exceptions taken by both parties and confirmed the report of the Special Master.

In the quotation from the *Kimberly v. Arms* case, found in the opinion of this Court, is the following:

"It is not within the general province of a master to pass upon all the issues in an equity case, nor is it competent for the court to refer the entire decision of a case to him without the consent of the parties."

In that case the order of reference stated in part:

"Richard D. Harrison be and is hereby appointed a special master herein to hear the evidence and *decide all the issues* between the parties," etc. (Italics ours.)

In the instant case, the order provided that the Master "take and hear the evidence offered by the respective parties and make his conclusion as to the facts in issue and recommend the judgment to be entered thereon" * * * "reserving to the Court the full right and power to review and determine all questions of fact and law upon exceptions to the report of said Special Master by the respective parties, as fully and completely had this reference not been made and as though this cause had been tried before the Court;"

Under the terms of the reference, just quoted, the Court did not "of its own motion, or upon the request of one party abdicate its duty to determine by its own judgment the controversy presented." as stated in the *Kimberly v. Arms* case, but on the contrary specifically ordered and reserved to the District Court the full right and power to review and determine all questions of fact and law upon exceptions to the Master's report. This Court, in the

case of *Smith v. Howland*, 11 F. (2d) pp. 9-13, in an opinion written by Hunt, Circuit Judge, stated:

“(2) To enter upon an extended statement of the evidence upon the merits would greatly lengthen this opinion, and is unnecessary. The findings of fact, having been approved by the District Court after a review of the evidence, are to be taken as presumptively correct, and unless obvious error has intervened in applying some principle of law or some important mistake has occurred in weighing the evidence, the decree will not be reversed. *Furrer v. Ferris*, 12 S. Ct. 821, 145 U. S. 132, 36 L. Ed. 649; *Road Imp. Dist. v. Wilkerson* (C. C. A.) 5 F. (2d) 416.”

The Supreme Court in the case of *Furrer v. Ferris*, 145 U. S. p. 133, 36 L. Ed. pp. 649-651, stated:

“Upon the testimony, both the Master and the Circuit Court found that there was no negligence, and while such determination is not conclusive, it is very persuasive in this Court. In *Crawford v. Neal*, 144 U. S. 585 (36:552), it was said:

“The cause was referred to a Master to take testimony therein, “and to report to this court his findings of fact and his conclusions of law thereon.” This he did, and the court, after a review of the evidence, concurred in his finding and conclusions. Clearly, then, they are to be taken as presumptively correct, and unless some obvious error has intervened in the application of the law, or some serious or important mistake has been made in the consideration of the evidence, the decree should be permitted to stand. *Tilghman v. Proctor*, 125 U. S. 136 (31:664); *Kimberly v. Arms*, 129 U. S. 512 (32:764); *Evans v. State Bank*, 141 U. S. 107 (35:654).”

In the case of *Stoody Co. v. Mills Alloys*, 67 F. (2d) 807 (C. C. A. 9th Circuit), the wording of the Order of Reference was in substance the same as in the instant case, the Court reserving "the full right and power to review and determine all questions of fact and law," and while in that case both sides agreed to the reference it was not an agreement to permit the Master to dispose of the case without a review by the Court. In that case this Court then inquired into the degree of weight to be given to the Master's Findings of Fact concurred in and approved by the District Court, in a general reference made "as above set forth", and in arriving at its conclusions followed the law in *Smith v. Howland*, *supra*.

In the case of *Davis v. Schwartz*, 155 U. S. 631, 39 L. Ed. 289-293, the Court stated as follows:

"1. As the case was referred by the court to a master to report, not the evidence merely, but the facts of the case, and his conclusions of law thereon, we think that his finding, so far as it involves questions of fact, is attended by a presumption of correctness similar to that in the case of a finding by a referee, the special verdict of a jury, the findings of a circuit court in a case tried by the court under Revised Statutes, 649, or in an admiralty cause appealed to this court."

As stated in the *Stoody Co. v. Mills Alloys* case, referred to above, "the matter of invention is one of fact", and it is our contention that the Master having found invention, and after argument on exceptions to the Master's report, the District Court confirmed that report, that while this finding is not conclusive it should have great weight before this Court, and not be set aside unless clearly erroneous.

It is further our contention that it was not intended by the Supreme Court in the *Kimberly v. Arms* case, cited in this Court's opinion, to pronounce a rule substantially nullifying the Master's report or as stated by this Court in its opinion, that

“Under such circumstances, the report of the Master is entitled to little if any weight in this Court.”

Had the reference, in this case, been to the Master with full power to “decide all the issues” as in the *Kimberly v. Arms* case, the objection by one of the parties to such reference would have the effect quoted by this Court. But if where, as in this case, the Court reserved full power to review and where the case was fully argued on exceptions to the Master's report and the Court found the same as the Master, the same ruling is applied, then the objection of one party to a reference simply means that by such objection the work of the Master in his consideration of the evidence taken before him and the writing of his report is of little or no value.

On the second proposition, it is appellee's contention that the Master found correctly on the question of invention and that as such finding was adopted by the District Court, the findings, by both the Master and District Court, should have great weight on the question of invention before this Court.

On this proposition, to-wit, that the structure in issue involved invention, it is our contention that the Court has misconstrued the teachings of the patents in the art and their application on the question of invention to the patents in suit.

In the *Stoody Co. v. Mills Alloys* case, above referred to, this Court found that “the matter of invention is one of fact”.

Taking up first the patent to Heller and the reissue of that patent, this Court states, that the—

“mobility between socket and shaft or rod is not new. It is disclosed in the patents to Heller”.

A reference to these patents, Book of Exhibits, pp. 57-61, disclose that there is no contact between the shaft and the head of the club other than through a rubber sleeve which, as stated in the Heller patents, is the full length of the bore, in other words, the shaft is cushioned *throughout its length* and extending entirely through the head of the club, which is a different problem from that of the Barnhart patents where there is a metal to metal contact between the hosel and the shaft. The “mobility between socket and shaft” in the Barnhart patent, in so far as the claims in issue are involved, relates only to “the portion of the shaft within the outer end of the socket being movable relative to the latter” as stated in claim 10, in the second Barnhart patent and “the portion of the shaft near the outer end of said socket being freely movable within and relative to and about the outer end portion of said socket” as stated in claim 11 of the first Barnhart patent. From this it will appear that there is nothing in the Heller patent that teaches the solving of Barnhart’s problem and must have been so considered by the Patent Office; which is likewise true of the Robertson patent.

With reference to the Robertson patent, referred to by this Court, that patent, even granted that it may be considered analogous art, relates to a *handle* of a fishing rod.

Barnhart's inventions are directed to the *head* of the club and not to the handle portion where the problem is again entirely different from that of Robertson. To understand this merely consider casting with a fishing rod held by the *handle* and then the striking of a golf ball by the *head* of a golf club thirty inches from the handle of the club. This Court has quoted from the Robertson patent relating to the elasticity of the rod and consequently the bending of the rod from the tip of the rod to the "extreme end of the butt" which has to do particularly with the hollow handle of the Robertson rod *which permits the rod to bend within the handle*. Attention is called to the fact that the claims in issue do not refer to any structure relating to this feature which among others is disclosed in the Barnhart patent.

In the Lard patent referred to by this court the shaft fits the "tubular socket member 4" throughout the full length of the socket member, entirely unlike Barnhart.

The Barnhart patents issued in 1927, two years before the adoption of the Barnhart invention by the defendant. We believe that the Court, on this question of invention, should also taken into consideration the admission of the defendant in its catalogue as appears on page 17. of the Book of Exhibits, where it states "that these improvements are unique" and "this invention is so ingeniously worked out", etc., and the further fact that it was only after Barnhart published his invention that the defendant, the manufacturer, saw the advantages of such a construction and adopted it.

In our brief, before this Court on appeal, at pages 13 and 14, we have quoted from leading cases that the adoption and use by the defendant of the invention in issue

is sufficient to overcome attacks which may be made by defendant on the patentability of the invention of the patent. In this case there is the presumption of validity which attaches to the issuance of the patent by the Patent Office followed by the finding of the Master after hearing the evidence and argument, and the confirmance of the Master's finding by the Court after argument on exceptions, filed by defendant excepting particularly to the Master's finding that the Barnhart patents were "good and valid in law". [Tr. p. 160.]

It is noted that the Court has deemed the means of distributing the strain at the junction of shaft and hosel as "obvious" but the record, in this case, shows that it was not "obvious" until Barnhart made his invention, as for instance, the Robertson patent, issued in 1878, given the credit ascribed to it by this Court, did not affect golf club construction until the Barnhart patents in 1927. In this connection the Supreme Court, in the case of *Diamond Rubber Co. v. Consolidated Rubber Tire Co.*, 220 U. S. 435, 55 L. Ed. 531, stated as follows:

"Many things, and the patent law abounds in illustrations, seem obvious after they have been done, and, 'in the light of the accomplished result,' it is often a matter of wonder how they so long 'eluded the search of the discoverer and set at defiance the speculations of inventive genius.' *Pearl v. Ocean Mills*, 2 Bann. & Ard. 469, Fed. Cas. No. 10,876, 11 Off. Gaz. 2. *Knowledge after the event is always easy*, and problems once solved present no difficulties, indeed, may be represented as never having had any, and expert witnesses may be brought forward to show that the new thing which seemed to have eluded the search of the world was always ready at hand and easy to be seen by a merely skillful attention. But

the law has other tests of the invention than subtle conjectures of what might have been seen and yet was not. It regards a change as evidence of novelty, the acceptance and utility of change as a further evidence, even as demonstration. And it recognizes degrees of change, dividing inventions into primary and secondary, and as they are, one or the other, gives a proportionate dominion to its patent grant." (Italics ours.)

In conclusion, it is submitted that this Court should give substantial weight to the findings of fact by the Master, concurred in by the District Court and not set such findings aside unless clearly erroneous; and that the patents of the prior art referred to and discussed by this Court in its opinion do not deprive the claims in issue, of the Barnhart patent, of invention.

Respectfully submitted,

GEORGE E. BARNHART,

By FRANK L. A. GRAHAM,

His Attorney.

I hereby certify that the above petition is well grounded in law and proper to be filed and is not interposed for the purpose of delay.

FRANK L. A. GRAHAM,

Attorney for Appellee.

Los Angeles, California, February 3, 1936.

Copies of this petition for rehearing have been mailed to Counsel for appellant.

In the United States
Circuit Court of Appeals
For the Ninth Circuit.

THE REPUBLIC SUPPLY COMPANY OF CALIFORNIA, a corporation,

Complainant,

vs.

RICHFIELD OIL COMPANY OF CALIFORNIA, a corporation,

Defendant.

SECURITY-FIRST NATIONAL BANK OF LOS ANGELES, as Trustee, GEORGE ARMSBY, F. S. BAER, HARRY J. BAUER, STANTON GRIFFIS, ROBERT E. HUNTER and ALBERT E. VAN COURT, known and designated as Richfield Bondholders' Committee,

Appellants and Cross-Appellees,

vs.

UNIVERSAL CONSOLIDATED OIL COMPANY, a California corporation,

Intervenor, Appellee and Cross-Appellant.

THE CHASE NATIONAL BANK OF THE CITY OF NEW YORK, BANK OF AMERICA, a corporation, PAN AMERICAN PETROLEUM COMPANY, a corporation, WILLIAM C. McDUFFIE, as Receiver for Pan American Petroleum Company, a corporation, RICHFIELD OIL COMPANY OF CALIFORNIA, a corporation, UNITED STATES OF AMERICA, THE REPUBLIC SUPPLY COMPANY OF CALIFORNIA, a corporation, CITIES SERVICE COMPANY, a corporation, ROBERT C. ADAMS, THOMAS B. EASTLAND, EDWARD F. HAYES and RICHARD

(Continued on Inside Cover.)

Transcript of Record.

Upon Appeal from the District Court of the United States for the Southern District of California, Central Division.



W. MILLAR, known and designated as Pan American Bondholders' Committee, G. PARKER TOMS, ROBERT C. ADAMS, F. S. BAER, ROBERT E. HUNTER, HENRY S. McKEE and RICHARD W. MILLAR, known and designated as Richfield Pan American Reorganization Committee, WILLIAM C. McDUFFIE, as Receiver of Richfield Oil Company of California, SECURITY-FIRST NATIONAL BANK OF LOS ANGELES, a national banking association, PACIFIC AMERICAN COMPANY, a corporation, AMERICAN COMPANY, a corporation, MANUFACTURERS TRUST COMPANY OF NEW YORK, a corporation, CITIZENS NATIONAL TRUST & SAVINGS BANK OF LOS ANGELES, a national banking association, FIRST NATIONAL BANK AND TRUST COMPANY OF SEATTLE, a national banking association, CONTINENTAL ILLINOIS BANK AND TRUST COMPANY, a corporation, THE FIRST NATIONAL BANK OF CHICAGO, a national banking association, CHEMICAL NATIONAL BANK AND TRUST COMPANY, a national banking association, and CALIFORNIA BANK, a corporation, M. W. LOWERY, HENRY S. McKEE, O. C. FIELD, R. R. TEMPLETON, known and designated as Richfield Unsecured Creditors' Committee,

Appellees.



In the United States
Circuit Court of Appeals
For the Ninth Circuit.

THE REPUBLIC SUPPLY COMPANY OF CALIFORNIA, a corporation,
Complainant,
vs.
RICHFIELD OIL COMPANY OF CALIFORNIA, a corporation,
Defendant.

SECURITY-FIRST NATIONAL BANK OF LOS ANGELES, as
Trustee, GEORGE ARMSBY, F. S. BAER, HARRY J. BAUER,
STANTON GRIFFIS, ROBERT E. HUNTER and ALBERT E.
VAN COURT, known and designated as Richfield Bondholders'
Committee,
Appellants and Cross-Appellants,
vs.
UNIVERSAL CONSOLIDATED OIL COMPANY, a California corporation,
Intervenor, Appellee and Cross-Appellant.

THE CHASE NATIONAL BANK OF THE CITY OF NEW YORK,
BANK OF AMERICA, a corporation, PAN AMERICAN PETROLEUM COMPANY, a corporation, WILLIAM C. McDUFFIE, as Receiver for Pan American Petroleum Company, a corporation, RICHFIELD OIL COMPANY OF CALIFORNIA, a corporation, UNITED STATES OF AMERICA, THE REPUBLIC SUPPLY COMPANY OF CALIFORNIA, a corporation, CITIES SERVICE COMPANY, a corporation, ROBERT C. ADAMS, THOMAS B. EASTLAND, EDWARD F. HAYES and RICHARD

(Continued on following page.)

Transcript of Record.

Upon Appeal from the District Court of the United States for the Southern District of California, Central Division.



W. MILLAR, known and designated as Pan American Bondholders' Committee, G. PARKER TOMS, ROBERT C. ADAMS, F. S. BAER, ROBERT E. HUNTER, HENRY S. McKEE and RICHARD W. MILLAR, known and designated as Richfield Pan American Reorganization Committee, WILLIAM C. McDUFFIE, as Receiver of Richfield Oil Company of California, SECURITY-FIRST NATIONAL BANK OF LOS ANGELES, a national banking association, PACIFIC AMERICAN COMPANY, a corporation, AMERICAN COMPANY, a corporation, MANUFACTURERS TRUST COMPANY OF NEW YORK, a corporation, CITIZENS NATIONAL TRUST & SAVINGS BANK OF LOS ANGELES, a national banking association, FIRST NATIONAL BANK AND TRUST COMPANY OF SEATTLE, a national banking association, CONTINENTAL ILLINOIS BANK AND TRUST COMPANY, a corporation, THE FIRST NATIONAL BANK OF CHICAGO, a national banking association, CHEMICAL NATIONAL BANK AND TRUST COMPANY, a national banking association, and CALIFORNIA BANK, a corporation, M. W. LOWERY, HENRY S. McKEE, O. C. FIELD, R. R. TEMPLETON, known and designated as Richfield Unsecured Creditors' Committee,

Appellees.



INDEX.

[Clerk's Note: When deemed likely to be of an important nature, errors or doubtful matters appearing in the original record are printed literally in italics; and, likewise, cancelled matter appearing in the original record is printed and cancelled herein accordingly. When possible, an omission from the text is indicated by printing in italics the two words between which the omission seems to occur.]

	PAGE
Acknowledgment of service of citation on appeal from order of September 17, 1934 and of assignment of errors thereon.....	12
Acknowledgment of service of citation on appeal from order of September 26, 1934 and of assignment of errors thereon.....	22
Acknowledgment of service of citation on cross-appeal from order of September 26, 1934 and of assignment of errors thereon.....	31
Agreed statement of the case.....	47
Appointment of special master to hear the issues presented by bill in intervention.....	96
Bill in intervention of Universal Consolidated Oil Company and answers.....	66
Answer of Richfield Oil Company, et al., to bill in intervention.....	87
Answer of Security-First National Bank of Los Angeles, as trustee, to bill in intervention.....	83
Bill in intervention of Universal Consolidated Oil Company	67
Bill of complaint of Security-First National Bank of Los Angeles to foreclose trust indenture.....	65
Claim of Universal Consolidated Oil Company.....	53

	PAGE
Creditor's action for appointment of receiver.....	50
Exceptions to reports of the special master.....	208
Exceptions of Security-First National Bank, et al.	208
Exceptions of Universal Consolidated Oil Com- pany	214
Exceptions to conclusions of law.....	223
Order appointing receiver.....	51
Order approving agreed statement of case.....	232
Order directing creditors to file claims.....	52
Orders and decrees of the United States District Court	226
Orders appointing special master to hear claims.....	64
Statement of evidence.....	96
Schedule A—Summarization of the evidence.....	102
Schedule B—Description of properties upon which liens are claimed by Universal.....	106
Findings and conclusions of special master.....	109
I. Report on claim.....	109
Conclusions	109
Findings	109
II. Report on bill in intervention.....	115
Findings and conclusions.....	115
Findings of fact.....	118
I. On the question of misappropriation or loan.....	118
II. The tracing of the money.....	143
Summary	159
Conclusions	163
I. Character of the transaction.....	163
II. Effect of the transaction.....	172

	PAGE
III. Tracing the trust money into property	173
IV. Interest	201
V. Counterclaim of receiver for payments on properties.....	203
VI. Status of the bond trustee.....	204
VII. Recommendation	205

Assignment of errors of Security-First National Bank, et al., on appeal from order of September 17, 1934..236

Assignment of errors of Security-First National Bank, et al., on appeal from order of September 26, 1934...251

Assignment of errors of Universal Consolidated Oil Company on appeal from order of September 26, 1934

266

Bond of Security-First National Bank, et al., on appeal from order of September 17, 1934.....244

Bond of Universal Consolidated Oil Company on appeal from order of September 26, 1934.....272

Bond on appeal of Security-First National Bank, et al., from order of September 26, 1934.....259

Clerk's certificate.....286

Citation on appeal from order of September 17, 1934.. 8

Citation on appeal from order of September 26, 1934.. 18

Citation on cross-appeal from order of September 26, 1934

28

Decree dated September 17, 1934..... 36

Decree dated September 26, 1934..... 41

	PAGE
Minutes of the court—September 26, 1934—order confirming report of special master and overruling exceptions, etc.....	41
Minutes of the court—December 17, 1934—order allowing appeal of Security-First National Bank, et al., from order of September 17, 1934, and fixing bond	40
Minutes of the court—December 26, 1934—order allowing appeal of Security-First National Bank, et al., from order of September 26, 1934, and fixing bond	45
Names and addresses of attorneys.....	1
Order, September 17, 1934, adopting findings and recommendations of special master.....	36
Order, September 26, 1934, confirming report of special master and overruling exceptions, etc.....	41
Order, December 17, 1934, allowing appeal of Security-First National Bank, et al., and fixing bond.....	40
Order, December 26, 1934, allowing appeal of Security-First National Bank, et al., from order of September 26, 1934, and fixing bond.....	45
Order allowing appeal of Security-First National Bank, et al., from order of September 17, 1934, and fixing bond	242
Order allowing appeal of Security-First National Bank, et al., from order of September 26, 1934, and fixing bond	257
Order allowing appeal of Universal Consolidated Oil Company from order of September 26, 1934, and fixing bond.....	264

Order approving bond on appeal of Security-First National Bank, et al., from order of September 17, 1934	246
Order approving bond of Security-First National Bank, et al., on appeal from order of September 26, 1934....	261
Order approving bond of Universal Consolidated Oil Company on appeal from order of September 26, 1934	274
Order fixing bond on appeal by Security-First National Bank, et al., from order of September 17, 1934.....	242
Order fixing bond on appeal of Security-First National Bank, et al., from order of September 26, 1934.....	257
Order fixing bond on appeal of Universal Consolidated Oil Company from order of September 26, 1934.....	265
Petition of Security-First National Bank, et al., for appeal from order of September 17, 1934.....	233
Petition of Security-First National Bank, et al., for appeal from order of September 26, 1934.....	248
Petition of Universal Consolidated Oil Company for appeal from order of September 26, 1934.....	263
Statement of the case (see agreed statement of the case).	
Stipulation as to contents of transcript of record on appeals from orders of September 17, 1934 and September 26, 1934.....	276



Names and Addresses of Attorneys.

For Appellant and Cross-Appellee Security-First National
Bank of Los Angeles, as Trustee:

O'MELVENEY, TULLER & MYERS, Esqs.,

WALTER K. TULLER, Esq.,

HARRY L. DUNN, Esq.,

PIERCE WORKS, Esq.,

CLINTON LA TOURRETTE, Esq.,

900 Title Insurance Building,

Los Angeles, California.

For Appellants and Cross-Appellees George Arbsby, F. S.
Baer, Harry J. Bauer, Stanton Griffis, Robert E. Hunter
and Albert E. Van Court, constituting the Richfield
Bondholders' Committee:

BAUER, MACDONALD, SCHULTHEIS &
PETTIT, Esqs.,

ALEXANDER MACDONALD, Esq.,

A. S. HALSTED, JR., Esq.,

621 South Spring Street,

Los Angeles, California.

For Appellee and Cross-Appellant Universal Consolidated
Oil Company:

A. L. WEIL, Esq.,

MARTIN WEIL, Esq.,

108 West Second Street,

Los Angeles, California.

LE ROY M. EDWARDS, Esq.,

810 South Flower Street,

Los Angeles, California.

For Appellees M. W. Lowery, Henry S. McKee, O. C.
Field and R. R. Templeton, constituting Unsecured
Creditors' Committee—Richfield Oil Company of Cali-
fornia:

CHANDLER, WRIGHT & WARD, Esqs.,

LEO S. CHANDLER, Esq.,

JOHN F. GILBERT, Esq.,

631 Van Nays Building,

Los Angeles, California.

CALL & MURPHEY, Esqs.,

ROBERT B. MURPHEY, Esq.,

ALEXANDER DAVIS, Esq.,

514 Pacific Mutual Building,

Los Angeles, California.

For Appellee The Chase National Bank of the City of
New York:

MUDGE, STERN, WILLIAMS & TUCKER,
Esqs.,

J. V. KLINE, Esq.,

20 Pine Street,

New York, New York.

FRESTON & FILES, Esqs.,

CLARENCE M. HANSON, Esq.,

650 South Spring Street,

Los Angeles, California.

For Appellee Bank of America:

MUDGE, STERN, WILLIAMS & TUCKER,
Esqs.,

J. V. KLINE, Esq.,

20 Pine Street,

New York, New York.

FRESTON & FILES, Esqs.,

CLARENCE M. HANSON, Esq.,

650 South Spring Street,

Los Angeles, California.

For Appellee Pan American Petroleum Company:

CLAYTON T. COCHRAN, Esq.,

741 Richfield Building,

Los Angeles, California.

For Appellee William C. McDuffie, as Receiver for Pan American Petroleum Company:

MORTIMER A. KLINE, Esq.,
Union Oil Building,
Los Angeles, California.

GIBSON, DUNN & CRUTCHER, Esqs.,
HOMER D. CROTTY, Esq.,
HERBERT F. STURDY, Esq.,
634 South Spring Street,
Los Angeles, California.

For Appellee Richfield Oil Company of California:

WILLIAM J. deMARTINI, Esq.,
306 Richfield Building,
Los Angeles, California.

For Appellee United States of America:

ATLEE POMERENE, Esq.,
H. J. CRAWFORD, Esq.,
FRANK HARRISON, Esq.,
Special Assistants to the Attorney General of
the United States,

Union Trust Building,
Cleveland, Ohio.

PEIRSON M. HALL, Esq.,
United States Attorney,
508 Federal Building,
Los Angeles, California.

JOHN R. LAYNG, Esq.,
Special Assistant United States Attorney,
1018 Board of Trade Building,
Los Angeles, California.

For Appellee The Republic Supply Company of California :

CHANDLER, WRIGHT & WARD, Esqs.,

LEO S. CHANDLER, Esq.,

JOHN F. GILBERT, Esq.,

631 Van Nuys Building,

Los Angeles, California.

For Appellee Cities Service Company :

HILL, MORGAN & BLEDSOE, Esqs.,

BENJAMIN F. BLEDSOE, Esq.,

639 Roosevelt Building,

Los Angeles, California.

ELVON MUSICK, Esq.,

GEORGE MARTINSON, Esq.,

1175 Subway Terminal Building,

Los Angeles, California.

For Appellees Robert C. Adams, Thomas B. Eastland,
Edward F. Hayes and Richard W. Millar, constituting
Pan American Bondholders' Committee :

CRAVATH, deGERSDORFF, SWAINE &
WOOD, Esqs.,

15 Broad Street,

New York, New York.

COLIN C. IVES, Esq.,

621 South Spring Street,

Los Angeles, California.

For Appellees G. Parker Toms, Robert C. Adams, F. S. Baer, Robert E. Hunter, Henry S. McKee and Richard W. Millar, constituting Richfield Pan American Re-organization Committee:

BAUER, MACDONALD, SCHULTHEIS &
PETTIT, Esqs.,

ALEXANDER MACDONALD, Esq.,

A. S. HALSTED, JR., Esq.,

621 South Spring Street,

Los Angeles, California.

CRAVATH, deGERSDORFF, SWAINE &
WOOD, Esqs.,

15 Broad Street,

New York, New York.

COLIN C. IVES, Esq.,

621 South Spring Street,

Los Angeles, California.

CHANDLER, WRIGHT & WARD, Esqs.,

LEO S. CHANDLER, Esq.,

JOHN F. GILBERT, Esq.,

631 Van Nuys Building,

Los Angeles, California.

CALL & MURPHEY, Esqs.,

ROBERT B. MURPHEY, Esq.,

ALEXANDER DAVIS, Esq.,

514 Pacific Mutual Building,

Los Angeles, California.

For Appellee William C. McDuffie, as Receiver of Rich-
field Oil Company of California:

GIBSON, DUNN & CRUTCHER, Esqs.,

HOMER D. CROTTY, Esq.,

HERBERT F. STURDY, Esq.,

634 South Spring Street,

Los Angeles, California.

For Appellees Pacific American Company, American Com-
pany, Manufacturers Trust Company of New York, Cit-
izens National Trust & Savings Bank of Los Angeles,
First National Bank and Trust Company of Seattle,
Continental Illinois Bank and Trust Company, Security-
First National Bank of Los Angeles, The First National
Bank of Chicago, Chemical National Bank and Trust
Company, and California Bank:

CALL & MURPHEY, Esqs.,

ROBERT B. MURPHEY, Esq.,

ALEXANDER DAVIS, Esq.,

514 Pacific Mutual Building,

Los Angeles, California.

IN THE DISTRICT COURT OF THE UNITED STATES FOR THE SOUTHERN DISTRICT OF CALIFORNIA CENTRAL DIVISION.

THE REPUBLIC SUPPLY COM-)
PANY OF CALIFORNIA, a cor-)
poration,)
Complainant,)

vs.)

RICHFIELD OIL COMPANY OF)
CALIFORNIA, a corporation,)
Defendant.)

SECURITY-FIRST NATIONAL)
BANK OF LOS ANGELES, a na-)
tional banking association, as trustee,)
Plaintiff,)

vs.)

RICHFIELD OIL COMPANY OF)
CALIFORNIA, a corporation, and)
WILLIAM McDUFFIE, as Re-)
ceiver of Richfield Oil Company of)
California, a corporation,)
Defendants.)

IN EQUITY
CONSOLIDATED
CAUSE
NO. S-125-J
CITATION ON
APPEAL.

)

UNIVERSAL CONSOLIDATED)
 OIL COMPANY, a California cor-)
 poration,)
 Intervenor.)
)

UNITED STATES OF AMERICA)
 (SS.
 NINTH JUDICIAL CIRCUIT)

To The Chase National Bank of the City of New York, a national banking association, Bank of America, a corporation, Pan American Petroleum Company, a corporation, William C. McDuffie, as Receiver of Richfield Oil Company of California, a corporation, William C. McDuffie, as Receiver of Pan American Petroleum Company, a corporation, Richfield Oil Company of California, a corporation, The United States of America, The Republic Supply Company of California, a corporation, Cities Service Company, a corporation, Universal Consolidated Oil Company, a corporation, M. W. Lowery, Henry S. McKee, O. C. Field and R. R. Templeton (known and designated as Richfield Unsecured Creditors' Committee), Robert C. Adams, Thomas B. Eastland, Edward F. Hayes and Richard W. Millar (known and designated as Pan American Bondholders' Committee), G. Parker Toms, Robert C. Adams, F. S. Baer, Robert E. Hunter, Henry S. McKee and Richard W. Millar (known and designated as Richfield-Pan American Reorganization Committee), Security-First National Bank of Los Angeles, a national

banking association, Pacific American Company, a corporation, American Company, a corporation, Manufacturers Trust Company of New York, a corporation, Citizens National Trust & Savings Bank of Los Angeles, a national banking association, First National Bank and Trust Company of Seattle, a national banking association, Continental Illinois Bank and Trust Company, a corporation, The First National Bank of Chicago, a national banking association, Chemical National Bank and Trust Company, a national banking association, and California Bank, a corporation, appellees, GREETING:

You, and each of you, are hereby cited and admonished to appear at a Session of the United States Circuit Court of Appeals for the Ninth Circuit to be held in the City of San Francisco, State of California, in said Circuit within thirty (30) days of the date of this writ, pursuant to an order filed in the office of the Clerk of the United States District Court for the Southern District of California, Central Division, allowing an appeal by Security-First National Bank of Los Angeles, a national banking association, as trustee, plaintiff herein, George Armsby, F. S. Baer, Harry J. Bauer, Stanton Griffis, Robert E. Hunter and Albert E. Van Court constituting the Richfield Bondholders' Committee, a committee formerly and at the time of the filing of the claim of Richfield Bondholders' Committee herein referred to constituted of Nion R. Tucker, George Armsby, Stanton Griffis, Robert E. Hunter and Harry J. Bauer, interveners herein, petitioners and appellants in the above entitled cause (designated as In Equity, Consolidated Cause No. S-125-J), from that

certain order, judgment and decree made and entered by said United States District Court in said cause on September 17, 1934, adjudicating each, all and sundry the exceptions filed to the Report of the Honorable William A. Bowen, Special Master in said cause, with reference to the bill in intervention of Universal Consolidated Oil Company, which Report was filed on May 26, 1933, in which appeal you, the parties first above mentioned, are appellees, and the said Security-First National Bank of Los Angeles, a national banking association, as trustee, plaintiff herein, George Armsby, F. S. Baer, Harry J. Bauer, Stanton Griffis, Robert E. Hunter and Albert E. Van Court constituting the Richfield Bondholders' Committee, a committee formerly and at the time of the filing of the claim of Richfield Bondholders' Committee herein referred to constituted of Nion R. Tucker, George Armsby, Stanton Griffis, Robert E. Hunter and Harry J. Bauer, interveners herein, are appellants, to show cause, if any there be, why said order, Judgment and decree of said United States District Court above mentioned should not be corrected and speedy justice should not be done to the parties in that behalf.

WITNESS the Honorable William P. James, United States District Judge of the Southern District of California, Ninth Judicial Circuit, this 17 day of December, 1934.

Wm. P. James

United States District Judge.

[Endorsed]: Filed Dec. 31, 1934. R. S. Zimmerman, Clerk. By Edmund L. Smith, Deputy Clerk.

[TITLE OF COURT AND CAUSE.]

ACKNOWLEDGMENT OF SERVICE OF CITATION ON APPEAL AND ASSIGNMENT OF ERRORS

Due service and receipt of the copy of Citation on Appeal and the Assignment of Errors, copies of which are attached hereto marked Exhibits A and B, respectively, are acknowledged by the undersigned on the dates set opposite their respective names.

Mudge, Stern, Williams & Tucker,
20 Pine Street,
New York, New York.

Freston & Files,
650 South Spring Street,
Los Angeles, California.

Dec. 21st, 1934. By Clarence M. Hanson

As attorneys of record for The Chase National Bank of the City of New York, a national banking association.

Mudge, Stern, Williams & Tucker,
20 Pine Street,
New York, New York,

Freston & Files,
650 South Spring Street,
Los Angeles, California.

Dec. 21st, 1934. By Clarence M. Hanson

As attorneys of record for Bank of America, a corporation.

Clayton T. Cochran,
704 Richfield Building,
Los Angeles, California.

Dec. 21st, 1934. By Clayton T. Cochran

As attorney of record for Pan American
Petroleum Company, a corporation.

Gibson, Dunn & Crutcher,
634 South Spring Street,
Los Angeles, California.

Mortimer A. Kline,
Union Oil Building,
Los Angeles, California.

Dec. 21, 1934. By Gibson, Dunn & Crutcher M K

As attorneys of record for William C. Mc-
Duffie, as Receiver of Pan American Pe-
troleum Company.

Gibson, Dunn & Crutcher,
634 South Spring Street,
Los Angeles, California.

Dec. 21, 1934. By Gibson, Dunn & Crutcher M K

As attorneys of record for William C. Mc-
Duffie as Receiver of Richfield Oil Company
of California, a corporation.

William J. De Martini,
306 Richfield Building,
Los Angeles, California.

Dec. 21, 1934. By Wm J De Martini H S

As attorney of record for Richfield Oil Com-
pany of California, a corporation.

Atlee Pomerene, H. J. Crawford,
Frank Harrison,
Union Trust Building,
Cleveland Ohio.

Pierson M. Hall,
508 Federal Building,
Los Angeles, California.

John R. Layng,
1018 Board of Trade Building,
Los Angeles, California.

Dec. 21st, 1934. By John R Layng S S

As attorneys of record for The United
States of America.

Chandler, Wright & Ward,
631 Van Nuys Building,
Los Angeles, California.

Dec. 21, 1934. By Leo S. Chandler F

As attorneys of record for The Republic
Supply Company of California, a corpora-
tion.

Hill, Morgan & Bledsoe,
639 Roosevelt Building,
Los Angeles, California.

Elvon Musick,
Subway Terminal Building,
Los Angeles, California.

Dec. 21, 1934. By Hill, Morgan & Bledsoe and

As attorneys of record for Cities Service
Company, a corporation.

A. L. Weil,
108 West Second Street,
Los Angeles, California.

LeRoy M. Edwards,
810 South Flower Street,
Los Angeles, California.

Frankley & Spray,
727 West Seventh Street,
Los Angeles, California.

Dec. 21, 1934. By LeRoy M. Edwards M D

As attorneys of record for Universal Consolidated Oil Company, a corporation.

Chandler, Wright & Ward,
631 Van Nuys Building,
Los Angeles, California.

Call & Murphey,
Pacific Mutual Building,
Los Angeles, California.

Dec. 21, 1934. By Leo S. Chandler F

As attorneys of record for M. W. Lowery, Henry S. McKee, O. C. Field and R. R. Templeton (known and designated as Richfield Unsecured Creditors' Committee)

Colin C. Ives,
621 South Spring Street,
Los Angeles, California,

or

Cravath, deGersdorff, Swaine & Wood,
15 Broad Street,
New York, New York.

Dec. 31, 1934. By Colin C. Ives

As attorneys of record for Robert C. Adams, Thomas B. Eastland, Edward F. Hayes and Richard W. Millar (known and designated as Pan American Bondholders' Committee)

Bauer, Macdonald, Schultheis & Pettit,
621 South Spring Street,
Los Angeles, California.

Cravath, deGersdorff, Swaine & Wood,
15 Broad Street,
New York, New York.

Chandler, Wright & Ward,
631 Van Nuys Building,
Los Angeles, California.

Call & Murphey,
Pacific Mutual Building,
Los Angeles, California.

Dec. 21, 1934. By Leo S. Chandler F

As attorneys of record for G. Parker Toms, Robert C. Adams, F. S. Baer, Robert E. Hunter, Henry S. McKee and Richard W. Millar (known and designated as Richfield-Pan American Reorganization Committee).

Call & Murphey,
514 Pacific Mutual Building,
Los Angeles, California.

Dec. 21, 1934. By Call & Murphey L R

As attorneys of record for Security-First National Bank of Los Angeles, a national banking association, Pacific American Company, a corporation, American Company, a corporation, Manufacturers Trust Company of New York, a corporation, Citizens National Trust & Savings Bank of Los Angeles, a national banking association, First National Bank and Trust Company of Seattle, a national banking association, Continental Illinois Bank and Trust Company, a corporation, The First National Bank of Chicago, a national banking association, Chemical National Bank and Trust Company, a national banking association, and California Bank, a corporation.

[Endorsed]: Filed Dec. 31, 1934. R. S. Zimmerman,
Clerk By Edmund L. Smith, Deputy Clerk.

IN THE DISTRICT COURT OF THE UNITED STATES FOR THE SOUTHERN DISTRICT OF CALIFORNIA CENTRAL DIVISION

THE REPUBLIC SUPPLY COM-)
 PANY OF CALIFORNIA, a cor-)
 poration,)

Complainant,)

vs.)

RICHFIELD OIL COMPANY OF)
 CALIFORNIA, a corporation,)

Defendant.)

SECURITY-FIRST NATIONAL)
 BANK OF LOS ANGELES, a na-)
 tional banking association, as trustee,)

Plaintiff,)

vs.)

IN EQUITY)
 CONSOLIDATED)
 CAUSE)

RICHFIELD OIL COMPANY OF)
 CALIFORNIA, a corporation, and)
 WILLIAM McDUFFIE, as Re-)
 ceiver of Richfield Oil Company of)
 California, a corporation,)

NO. S-125-J)
 CITATION ON)
 APPEAL)
 (Order of Septem-)
 ber 26, 1934))

Defendants.)

)

UNIVERSAL CONSOLIDATED)
 OIL COMPANY, a California cor-)
 poration,)
 Intervenor.)
)

UNITED STATES OF AMERICA)
) SS.
 NINTH JUDICIAL CIRCUIT)

To The Chase National Bank of the City of New York, a national banking association, Bank of America, a corporation, Pan American Petroleum Company, a corporation, William C. McDuffie, as Receiver of Richfield Oil Company of California, a corporation, William C. McDuffie, as Receiver of Pan American Petroleum Company, a corporation, Richfield Oil Company of California, a corporation, The United States of America, The Republic Supply Company of California, a corporation, Cities Service Company, a corporation, Universal Consolidated Oil Company, a corporation, M. W. Lowery, Henry S. McKee, O. C. Field and R. R. Templeton (known and designated as Richfield Unsecured Creditors' Committee), Robert C. Adams, Thomas B. Eastland, Edward F. Hayes and Richard W. Millar (known and designated as Pan American Bondholders' Committee), G. Parker Toms, Robert C. Adams, F. S. Baer, Robert E. Hunter, Henry S. McKee and Richard W. Millar (known and designated as Richfield-Pan American Reorganization Committee), Security-First National Bank of Los Angeles, a national banking association, Pacific American Company, a corporation, American Company, a corporation, Manufac-

turers Trust Company of New York, a corporation, Citizens National Trust & Savings Bank of Los Angeles, a national banking association, First National Bank and Trust Company of Seattle, a national banking association, Continental Illinois Bank and Trust Company, a corporation, The First National Bank of Chicago, a national banking association, Chemical National Bank and Trust Company, a national banking association, and California Bank, a corporation, appellees, GREETING:

You, and each of you, are hereby cited and admonished to appear at a Session of the United States Circuit Court of Appeals for the Ninth Circuit to be held in the City of San Francisco, State of California, in said Circuit within thirty (30) days of the date of this writ, pursuant to an order filed in the office of the Clerk of the United States District Court for the Southern District of California, Central Division, allowing an appeal by Security-First National Bank of Los Angeles, a national banking association, as trustee, plaintiff herein, George Armsby, F. S. Baer, Harry J. Bauer, Stanton Griffis, Robert E. Hunter and Albert E. Van Court constituting the Richfield Bondholders' Committee, a committee formerly and at the time of the filing of the claim of Richfield Bondholders' Committee herein constituted of Nion R. Tucker, George Armsby, Stanton Griffis, Robert E. Hunter and Harry J. Bauer, interveners herein, petitioners and appellants in the above entitled cause (designated as In Equity, Consolidated Cause No. S-125-J), from that certain order, judgment and decree made and entered by said United States District Court in said cause on September 26, 1934, adjudicating each, all and sundry the exceptions filed to

the Report of the Honorable William A. Bowen, Special Master in said cause, with reference to the bill in intervention of Universal Consolidated Oil Company, which Report was filed on May 26, 1933, in which appeal you, the parties first above mentioned, are appellees, and the said Security-First National Bank of Los Angeles, a national banking association, as trustee, plaintiff herein, George Armsby, F. S. Baer, Harry J. Bauer, Stanton Griffis, Robert E. Hunter and Albert E. Van Court constituting the Richfield Bondholders' Committee, a committee formerly and at the time of the filing of the claim of Richfield Bondholders' Committee herein referred to constituted of Nion R. Tucker, George Armsby, Stanton Griffis, Robert E. Hunter and Harry J. Bauer, interveners herein, are appellants, to show cause, if any there be, why said order, judgment and decree of said United States District Court above mentioned should not be corrected and speedy justice should not be done to the parties in that behalf.

WITNESS the Honorable William P. James, United States District Judge of the Southern District of California, Ninth Judicial Circuit, this 26th day of December, 1934.

Wm. P. James

United States District Judge.

[Endorsed]: Filed Jan. 10, 1935. R. S. Zimmerman,
Clerk By L. Wayne Thomas, Deputy Clerk.

[TITLE OF COURT AND CAUSE.]

ACKNOWLEDGMENT OF SERVICE OF CITATION ON APPEAL AND ASSIGNMENT OF ERRORS.

(Order of September 26, 1934)

Due service and receipt of the copy of Citation on Appeal and the Assignment of Errors, copies of which are attached hereto marked Exhibits A and B, respectively, are acknowledged by the undersigned on the dates set opposite their respective names.

Mudge, Stern, Williams & Tucker,
20 Pine Street,
New York, New York.

Freston & Files,
650 South Spring Street,
Los Angeles, California.

Jan. 4, 1935. By Clarence M. Hanson

As attorneys of record for The Chase National Bank of the City of New York, a national banking association.

Mudge, Stern, Williams & Tucker,
20 Pine Street,
New York, New York,

Freston & Files,
650 South Spring Street,
Los Angeles, California.

Jan. 4, 1935. By Clarence M. Hanson

As attorneys of record for Bank of America, a corporation.

Clayton T. Cochran,
704 Richfield Building,
Los Angeles, California.

Jan. 4, 1935.

By Clayton T. Cochran

As attorney of record for Pan American
Petroleum Company, a corporation.

Gibson, Dunn & Crutcher,
634 South Spring Street,
Los Angeles, California.

Mortimer A. Kline,
Union Oil Building,
Los Angeles, California.

Jan. 4th, 1935.

By Gibson Dunn & Crutcher

As attorneys of record for William C. Mc-
Duffie, as Receiver of Pan American Pe-
troleum Company.

Gibson, Dunn & Crutcher,
634 South Spring Street,
Los Angeles, California.

Jan. 4th, 1935

By Gibson Dunn & Crutcher

As attorneys of record for William C. Mc-
Duffie, as Receiver of Richfield Oil Company
of California, a corporation.

William J. De Martini,
306 Richfield Building,
Los Angeles, California.

Jan. 4th, 1935.

By WmJ De Martini H. S.

As attorney of record for Richfield Oil Com-
pany of California, a corp.

Atlee Pomerene, H. J. Crawford,
Frank Harrison,
Union Trust Building,
Cleveland, Ohio.

Pierson M. Hall,
508 Federal Building,
Los Angeles, California.

John R. Layng,
1018 Board of Trade Building,
Los Angeles, California.

Jan. 4, 1935. By John R Layng By S. S.

As attorneys of record for The United
States of America.

Chandler, Wright & Ward,
631 Van Nuys Building,
Los Angeles, California.

Jan. 4th, 1935. By Leo S. Chandler

As attorneys of record for The Republic
Supply Company of California, a corpora-
tion.

Hill, Morgan & Bledsoe,
639 Roosevelt Building,
Los Angeles, California.

Elvon Musick,
Subway Terminal Building,
Los Angeles, California.

Jan. 4, 1935. By Chas P. McCarthy M

As attorneys of record for Cities Service
Company, a corporation.

A. L. Weil,
108 West Second Street,
Los Angeles, California.

LeRoy M. Edwards,
810 South Flower Street,
Los Angeles, California.

Frankley & Spray,
727 West Seventh Street,
Los Angeles, California.

A L Weil

Jan. 4th, 1935. By LeRoy M Edwards by M. D.

As attorneys of record for Universal Consolidated Oil Company a corporation.

Chandler, Wright & Ward,
631 Van Nuys Building,
Los Angeles, California.

Call & Murphey,
Pacific Mutual Building,
Los Angeles, California.

Jan. 4, 1935. Call & Murphey L. R.

As attorneys of record for M. W. Lowery, Henry S. McKee, O. C. Field and R. R. Templeton (known and designated as Richfield Unsecured Creditors' Committee)

Colin C. Ives,
621 South Spring Street,
Los Angeles, California,

or

Cravath, deGersdorff, Swaine & Wood,
15 Broad Street,
New York, New York.

Jan. 4, 1935. By Colin C. Ives

As attorneys of record for Robert C. Adams, Thomas B. Eastland, Edward F. Hayes and Richard W. Millar (known and designated as Pan American Bondholders' Committee)

Bauer, Macdonald, Schultheis & Pettit,
621 South Spring Street,
Los Angeles, California.

Cravath, deGersdorff, Swaine & Wood,
15 Broad Street,
New York, New York.

Chandler, Wright & Ward,
631 Van Nuys Building,
Los Angeles, California.

Call & Murphey,
Pacific Mutual Building,
Los Angeles, California.

Jan. 4th, 1935. By Leo S. Chandler

As attorneys of record for G. Parker Toms, Robert C. Adams, F. S. Baer, Robert E. Hunter, Henry S. McKee and Richard W. Millar (known and designated as Richfield Pan American Reorganization Committee)

Call & Murphey,
514 Pacific Mutual Building,
Los Angeles, California.

Jan. 4, 1935. By Call & Murphey L. R.

As attorneys of record for Security-First National Bank of Los Angeles, a national banking association Pacific American Company, a corporation, American Company, a corporation, Manufacturers Trust Company of New York, a corporation, Citizens National Trust & Savings Bank of Los Angeles, a national banking association, First National Bank and Trust Company of Seattle, a national banking association, Continental Illinois Bank and Trust Company, a corporation, The First National Bank of Chicago, a national banking association, Chemical National Bank and Trust Company, a national banking association, and California Bank, a corporation.

[Endorsed]: Filed Jan. 10, 1935. R. S. Zimmerman
Clerk By L. Wayne Thomas, Deputy Clerk.

IN THE DISTRICT COURT OF THE UNITED STATES SOUTHERN DISTRICT OF CALIFORNIA CENTRAL DIVISION.

THE REPUBLIC SUPPLY COMPANY OF CALIFORNIA, a corporation,

Complainant,

vs.

RICHFIELD OIL COMPANY OF CALIFORNIA, a corporation,

Defendant.

----- SECURITY-FIRST NATIONAL BANK OF LOS ANGELES, a national banking association, as trustee,

Plaintiff,

vs.

RICHFIELD OIL COMPANY OF CALIFORNIA, a corporation, and WILLIAM McDUFFIE, as Receiver of Richfield Oil Company of California, a corporation,

Defendants.

----- UNIVERSAL CONSOLIDATED OIL COMPANY, a California corporation,

Intervenor.

IN EQUITY

CONSOLIDATED CAUSE

NO. S-125-J.

CITATION ON APPEAL

UNITED STATES OF AMERICA,)
) SS.
 NINTH JUDICIAL CIRCUIT.)

To SECURITY-FIRST NATIONAL BANK OF LOS ANGELES, a national banking association, The Chase National Bank of the City of New York, a national banking association, Bank of America, a corporation, Pan American Petroleum Company, a corporation, William C. McDuffie, as Receiver of Richfield Oil Company of California, a corporation, William C. McDuffie, as Receiver of Pan American Petroleum Company, a corporation, Richfield Oil Company of California, a corporation, The United States of America, The Republic Supply Company of California, a corporation, Cities Service Company, a corporation, M. W. Lowery, Henry S. McKee, O. C. Field and R. R. Templeton (known and designated as Richfield Unsecured Creditors' Committee), Robert C. Adams, Thomas B. Eastland, Edward F. Hayes and Richard W. Millar (known and designated as Pan American Bondholders' Committee), G. Parker Toms, Robert C. Adams, F. S. Baer, Robert E. Hunter, Henry S. McKee and Richard W. Millar (known and designated as Richfield-Pan American Reorganization Committee), Security-First National Bank of Los Angeles, a national banking association, Pacific American Company, a corporation, American Company, a corporation, Manufacturers Trust Company of New York, a corporation, Citizens National Trust & Savings Bank of Los Angeles, a national banking association, First National Bank and Trust Company of Seattle, a national banking association, Continental Illinois Bank and Trust Company, a corporation, The First National Bank of Chicago, a national banking

association, Chemical National Bank and Trust Company, a national banking association, and California Bank, a corporation, appellees, Greeting:

You, and each of you, are hereby cited and admonished to appear at a Session of the United States Circuit Court of Appeals for the Ninth Circuit to be held in the City of San Francisco, State of California, in said Circuit within thirty (30) days of the date of this writ, pursuant to an order filed in the office of the Clerk of the United States District Court for the Southern District of California, Central Division, allowing an appeal by Universal Consolidated Oil Company, a corporation, intervenor herein and petitioner and appellant in the above entitled cause (designated as In Equity, Consolidated Cause No. S-125-J), from that certain order, judgment and decree made and entered by said United States District Court in said cause on September 26, 1934, adjudicating each, all and sundry the exceptions filed to the Report of the Honorable William A. Bowen, Special Master in said cause, with reference to the bill in intervention of Universal Consolidated Oil Company, which Report was filed on May 26, 1933, in which appeal you, the parties first above mentioned, are appellees, and the said Universal Consolidated Oil Company, a corporation, intervenor herein, is appellant, to show cause, if any there be, why said order, judgment and decree of said United States District Court above mentioned should not be corrected and speedy justice should not be done to the parties in that behalf.

WITNESS the Honorable William P. James, United States District Judge of the Southern District of California, Ninth Judicial Circuit, this 26th day of December, 1934.

Wm P James

UNITED STATES DISTRICT JUDGE.

Received a copy of within citation and assignment this 26th day of December, 1934:

Bauer, Macdonald, Schultheis & Pettit

By M. Gillespie

(Bauer, Macdonald, Schultheis & Pettit)

Solicitors for Robert C. Adams, Thomas B. Eastland, Edward F. Hayes, and Richard W. Millar, constituting the Pan American Bondholders' Committee; George Armsby, F. S. Baer, Harry J. Bauer, Stanton Griffis, Robert E. Hunter, and Albert Van Court, constituting the Richfield Bondholders' Committee; G. Parker Thoms, Robert C. Adams, F. S. Baer, Robert E. Hunter, Henry S. McKee, and Richard W. Millar, constituting the Reorganization Committee.

Call & Murphey

By L. Robinson

(Call and Murphey)

Chandler, Wright & Ward

By Leo S. Chandler F.

(Chandler, Wright and Ward)

Solicitors for Henry S. McKee, O. C. Field, M. W. Lowreys, R. R. Templeton, and G. Parker Thoms, constituting the Richfield Unsecured Creditors' Committee;

Gibson, Dunn & Crutcher

By Homer D. Crotty
(Gibson, Dunn and Crutcher)

Solicitors for William C. McDuffie, as Receiver of Pan American Petroleum Company, William C. McDuffie as Receiver of Richfield Oil Company.

Received copy of the within Document, Dec. 27th, 1934

O'MELVENY, TULLER and MYERS
By Alex Rogers, Jr.

Solicitors for Security-First National Bank of Los Angeles, as Trustee.

Mudge, Stearn, Williams & Tucker
By Clarence M. Hanson
(Mudge, Stearn, Williams and Tucker)

Freston and Files by Clarence M. Hanson
Solicitors for The Chase National Bank of the City of New York, and Bank of America.

Wm J. De Martini
By H. Strand
(Wm. J. de Martini)

Solicitor for Richfield Oil Company of California.

By Hill, Morgan & Bledsoe &
Musick & Martinson M.
(Hill, Morgan and Bledsoe
Evon Musick, Geo. Martinson)

Solicitors for Cities Service Company, a corporation.

By Clayton T Cochran
(Clayton T. Cochran)

Solicitor for Pan American Petroleum Company.

Lobdell & Watt

By Harold L Watt
(Lobdell & Watt)

Solicitors for The Suffolk Corporation.

Bauer, Macdonald, Schultheis & Pettit

By M. Gillespie

(Bauer, Macdonald, Schultheis & Pettit)

Solicitors for G. Parker Thoms, Robert C. Adams, F. S. Baer, Robert E. Hunter, Henry S. McKee, and Richard W. Millar, constituting Reorganization Committee; George Armsby, F. S. Baer, Harry J. Bauer, Stanton Griffis, Robert E. Hunter, and Albert Van Court, constituting the Richfield Bondholders' Committee; Robert C. Adams, Thomas B. Eastland, Edward F. Hayes; and Richard W. Millar, constituting the Pan American Bondholders' Committee.

Call & Murphey

By L. Robinson
(Call and Murphey)

Solicitors for Henry S. McKee, O. C. Field, M. W. Lowrey, R. R. Templeton and G. Parker Thoms, constituting Richfield Unsecured Creditors' Committee; Pacific American Company, American Company, Manufactures Trust Company of New York, Citizens National Trust and Savings Bank of Los Angeles, First National Bank & Trust Company of Seattle, Continental Illinois Bank & Trust Company, The First National Bank of Chicago, Chemical National Bank & Trust Company, California Bank of Los Angeles, as Interveners, constituting the so-called Unsecured Bank Creditors' Committee.

Chandler, Wright & Ward

By Leo S. Chandler F.

(Chandler, Wright and Ward)

Solicitors for Henry S. McKee, O. C. Field, M. W. Lowrey, R. R. Templeton, and G. Parker Thoms, constituting Richfield Unsecured Creditors Committee; Pacific American Company, American Company, Manufactures Trust Company of New York, Citizens National Trust and Savings Bank of Los Angeles, First National Bank & Trust Company of Seattle, Continental Illinois Bank & Trust Company, The First National Bank of Chicago, Chemical National Bank & Trust Company, California Bank of Los Angeles, as Interveners, constituting the so-called Unsecured Bank Creditors' Committee; The Republic Supply Company of California.

Gibson, Dunn & Crutcher

By Homer D. Crotty

(Gibson, Dunn & Crutcher)

Solicitors for William C. McDuffie as Receiver of Richfield Oil Company of California; William C. McDuffie as Receiver for Pan American Petroleum Company.

Solicitors for Security-First National Bank of Los Angeles as Trustee; Security-First National Bank of Los Angeles.

Mudge, Stearn, Williams & Tucker

By Clarence M. Hanson

(Mudge, Stearns, Williams & Tucker)

Freston & Files

By Clarence M. Hanson

(Freston & Files)

Solicitors for The Chase National Bank of New York; Bank of America, Trustee,

Hill, Morgan & Bledsoe

By A. Morissey

(Hill, Morgan and Bledsoe)

Elvon Musick, Howard Burrell

By E. Perry Churchill

(Elvon Musick)

Solicitors for Cities Service Company, a corporation.

By Clayton T. Cochran

(Clayton T. Cochran)

Solicitor for Pan American Petroleum Company.

Dated at Los Angeles, California, this 27th day of December, 1934.

Atlee Pomerene by J R L

(Atlee Pomerene)

H. J. Crawford by J R L

(H. J. Crawford)

Frank Harrison by J R L

(Frank Harrison)

Special Assistants to the Attorney General of the United States.

Peirson M. Hall by J R L

(United States Attorney)

John R. Layng

(Special Assistant to the United States Attorney)

Solicitors for said Petitioner, United States of America.

[Endorsed]: Filed Jan. 10 1935 R. S. Zimmerman,
Clerk By L. Wayne Thomas Deputy Clerk.

UNITED STATES DISTRICT COURT
SOUTHERN DISTRICT OF CALIFORNIA
CENTRAL DIVISION

THE REPUBLIC SUPPLY COM-)	
PANY OF CALIFORNIA,)	
Complainant,)	
vs.)	No. S-125.
)	Consolidated
RICHFIELD OIL COMPANY OF)	Cause.
CALIFORNIA,)	
Defendant.)	

In the Matter of the claim of UNIVERSAL CONSOLIDATED OIL COMPANY, in contest as to the correctness of the findings of the Special Master that the claimant, under its complaint in intervention, is entitled to have an interest declared in its favor in various properties held by Richfield receiver.

In the intervention matter the Master determined that trust funds of the claimant, misappropriated by the former officers of Richfield, had been, by the evidence, traced into various properties which came into the Receiver's hands, and there remain; that the claimant should be adjudged to own interests in such properties to the extent of the money amounts so traced, and be allowed its claim as non-secured and nonpreferential, for the remainder of the debt. There was no dispute but that the claimant was entitled to recover the sum of \$1,183,148.23. The Master found that of the amount just stated, \$403,993.92 was

sufficiently traced as invested in properties, leaving a balance of \$779,154.31 as for a general and unsecured claim to be paid without preference.

With the debt amount admitted, the exceptions are made: first, by the claimant, which contends that a greater amount was traced into specific property than the Master found; secondly, by the Trustee for the bondholders, as well as by the Receiver, who contend that no amounts of money constituting trust funds were sufficiently traced into specific property. Involved in the latter contention is the claim that the transactions between the former officers of Richfield and the claimant company were those of borrower and lender simply, with no trust obligation resulting. The manifest interest of the Receiver here is, of course, only to perform his duty in seeing that all creditors are protected in their interests, and that the court shall have the assistance of his counsel in reaching a correct conclusion. The interest of the Trustee under the Richfield bonds is that in so far as the claimant Universal shall be held to have established a trust investment interest in property otherwise covered by the bond mortgage, to that extent the security of the bondholders is diminished. Unsecured creditors are interested for the opposite reason, i. e., that in so far as the claim of Universal may be satisfied out of otherwise mortgaged property, by just that much are proceeds from the sale of assets increased for distribution among them.

The Master, in an exhaustive opinion, reviewed the facts and discussed the decisions. As to his basic conclusion that the former officers of Richfield, acting through personal and selfish motives, and through their power on the Board of Directors of Universal, abstracted large amounts

of money, totalling the conceded sum, and used such monies in Richfield business, returning no security whatsoever to Universal, seems to me to be almost beyond even the suggestion of serious debate. The argument presented on the exceptions is pressed most strongly to the point, as to whether the Master correctly discerned and properly applied the equitable rules governing the rights of a beneficiary in pursuit of funds wrongly appropriated by a fiduciary. There is involved the matter of equitable practice in dealing with a case, as is this, where funds have been intermingled in a deposit account of the fiduciary; also where money has been drawn from such an account and invested in property. There is the question also as to what presumptions may be applied where the bank account of the fiduciary is constantly varying but never exhausted. The Master set up several possible ways under which the amount of trust money might be fixed under the conditions attending the bank transactions which affected the trust money. He presented in support of the conclusion finally reached the law, as it had been disclosed through the researches of himself and of counsel for the contending interests. If his conclusions are agreed to, his reasons must also be adopted, for they are clearly and ably stated, and support completely the judgment arrived at.

I have given the consideration to the exceptions filed, which the importance of the subject and the ability of counsel seriously contending, deserve. I am prepared to affirm the conclusions of the Master as against all excep-

tions filed. As I have heretofore stated, I do not believe it would be of any advantage to express my views in a lengthy opinion. We already have a very full exposition of the law made by the Master. Nothing could be gained by repeating an analysis of the decisions, or in again reciting extensively the facts. The result attained is certainly fair and equitable to all interests.

IT IS ORDERED that the Report of the Special Master recommending findings and decree in the suit of Universal Consolidated Oil Company, intervener, as filed in this Receivership proceeding, be and it is approved and confirmed; the findings and recommendations of the Master are adopted as those of the Court. The findings of the Special Master on the claim of the Universal Consolidated Oil Company, Master's Number 2637, as found on page 55 of the Master's Third Partial Report on Claims, as filed December 29, 1933, are approved and confirmed and adopted as the findings and conclusions of the Court. In the intervention suit it will be desirable that a formal decree be prepared and signed, supplementing the above order. The exceptions of the several parties appearing are overruled, and an exception is noted in their favor.

Dated September 17, 1934.

Wm. P. James

U. S. District Judge.

[Endorsed]: Filed Sep. 17, 1934. R. S. Zimmerman,
Clerk By Murray E. Wire, Deputy Clerk.

At a stated term, to wit: The September Term, A. D. 1934, of the District Court of the United States of America, within and for the Central Division of the Southern District of California, held at the Court Room thereof, in the City of Los Angeles, on Monday the 17th day of December in the year of our Lord one thousand nine hundred and thirty-four.

Present:

The Honorable: WM. P. JAMES, District Judge.

THE REPUBLIC SUPPLY COM-)
 PANY OF CALIFORNIA, a cor-)
 poration, Complainant,)

vs.)

RICHFIELD OIL COMPANY OF)
 CALIFORNIA a corporation,)
 Defendant.)

SECURITY - FIRST NATIONAL) In Equity
 BANK OF LOS ANGELES, a na-) Consolidated Cause
 tional banking association, as trustee) No. S-125-J.
 Plaintiff,)

vs.)

RICHFIELD OIL COMPANY OF)
 CALIFORNIA, a corporation, and)
 WILLIAM McDUFFIE, as Re-)
 ceiver of Richfield Oil Company of)
 California, a corporation,)
 Defendant.)

HARRY L. DUNN, of the firm of O'Melveny, Tuller & Myers, appearing at this time for and on behalf of plaintiff Security-First National Bank of Los Angeles, a national banking association, as trustee; George Armsby, F. S. Baer, Harry J. Bauer, Stanton Griffis, Robert E. Hunter and Albert E. Van Court, constituting the Richfield Bondholders' Committee, a committee formerly and at the time of the filing of the claim of Richfield Bondholders' Committee herein referred to, constituted of Nion R. Tucker, George Armsby, Stanton Griffis, Robert E. Hunter and Harry J. Bauer, interveners; and each of them, gives oral notice of appeal from that certain order, judgment and decree entered herein on September 17, 1934, adjudicating each, all and sundry the exceptions filed to the Report of the Honorable William A. Bowen, Special Master with reference to the bill of intervention of Universal Consolidated Oil Company, which report was filed May 26, 1933, and presents petition for appeal, assignments of error, and order allowing appeal, which order is allowed and signed by the court fixing the cost bond thereon at \$1000.00.

At a Term of the District Court of the United States, for the Southern District of California, Central Division, in the Ninth Judicial Circuit, held in the City of Los Angeles, State of California, on the 26 day of September, 1934.

IN THE DISTRICT COURT OF THE UNITED
STATES SOUTHERN DISTRICT OF CALI-
FORNIA CENTRAL DIVISION

THE REPUBLIC SUPPLY COM-)	IN EQUITY
PANY OF CALIFORNIA, a cor-)	CONSOLIDATED
poration,)	CAUSE
)	No. S-125-J
Complainant,)	
)	ORDER
vs.)	CONFIRMING
)	REPORT OF
RICHFIELD OIL COMPANY)	SPECIAL
OF CALIFORNIA, a corporation,)	MASTER ON
)	BILL IN
Defendant.)	INTERVENTION
_____)	OF UNIVERSAL
SECURITY-FIRST NATIONAL)	CONSOLIDATED
BANK OF LOS ANGELES, a na-)	OIL COMPANY
tional banking association, as trus-)	AND
tee,)	OVERRULING
Plaintiff,)	EXCEPTIONS
)	TO THE
vs.)	REPORT
)	ON THE CLAIM
RICHFIELD OIL COMPANY)	OF UNIVERSAL
OF CALIFORNIA, a corporation,)	CONSOLIDATED
and WILLIAM C. McDUFFIE, as)	OIL COMPANY,
Receiver of Richfield Oil Company)	MASTER'S
of California, a corporation,)	No. 2637,
)	CONTAINED IN
Defendants.)	THE SPECIAL
_____)	MASTER'S
UNIVERSAL CONSOLIDATED)	THIRD
OIL COMPANY, a California cor-)	PARTIAL
poration,)	REPORT ON
Intervenor.)	CLAIMS.

It appearing that William A. Bowen, Esq., appointed by this Court to pass upon the Bill in Intervention of Universal Consolidated Oil Company, and the pleadings in connection therewith, and said Special Master having on May 26, 1934, filed in the office of the Clerk of the above entitled court his report on the Bill in Intervention of Universal Consolidated Oil Company, and the parties to the above entitled cause having filed exceptions to said report, to-wit: Universal Consolidated Oil Company, Security-First National Bank of Los Angeles, and William C. McDuffie, as Receiver of Richfield Oil Company of California, and it further appearing that said Special Master had filed his Third Partial Report on Claims reporting on the claim of Universal Consolidated Oil Company, Master's No. 2637, to which said report exceptions were filed by Universal Consolidated Oil Company, Security-First National Bank of Los Angeles, and William C. McDuffie, as Receiver of Richfield Oil Company of California, and said reports and said exceptions having come on further to be heard at this term were argued by counsel, and thereupon upon consideration of said report and the exceptions thereto,

IT IS ORDERED, ADJUDGED AND DECREED as follows:

1. That said reports of said Special Master upon the claim of Universal Consolidated Oil Company, Intervenor herein, as filed in the receivership proceedings be and they hereby are approved and confirmed:

2. That the exceptions filed by all parties to said Special Master's Reports are hereby overruled:

3. That said Special Master's Reports on the claim of Universal Consolidated Oil Company and the memo-

randum opinion thereon, dated September 17, 1934, are hereby incorporated in this decree and made a part hereof as if specifically set forth; and

4. That an exception is noted in favor of the parties filing exceptions.

DATED: Los Angeles, California, September 26, 1934.

Wm P James
Judge

Approved as to form as required by Rule 44:

GIBSON, DUNN & CRUTCHER,
By Homer D. Crotty.

Counsel for William C. McDuffie as Receiver
of Richfield Oil Company of California.

O'MELVENY, TULLER & MYERS
By Pierce Works,

Counsel for Security-First National Bank of
Los Angeles.

A. L. Weil
LeRoy M Edwards
Frankley and Spray
By L. W. Frankley

Counsel for Universal Consolidated Oil Com-
pany.

Decree entered and recorded Sept. 26, 1934. R. S. Zimmerman, Clerk. By Murray E. Wire, Deputy Clerk.

[Endorsed]: Filed Sep. 26, 1934. R. S. Zimmerman, Clerk By Murray E. Wire, Deputy Clerk.

At a stated term, to wit: The September Term, A. D. 1934, of the District Court of the United States of America, within and for the Central Division of the Southern District of California, held at the Court Room thereof, in the City of Los Angeles on Wednesday the 26th day of December in the year of our Lord one thousand nine hundred and thirty-four.

Present:

The Honorable: WM. P. JAMES, District Judge.

THE REPUBLIC SUPPLY COM-)
 PANY OF CALIFORNIA, a cor-)
 poration, Complainant,)
 vs.)

RICHFIELD OIL COMPANY OF)
 CALIFORNIA, a corporation,)
 Defendant.)

SECURITY - FIRST NATIONAL)
 BANK OF LOS ANGELES, a na-)
 tional banking association, as Trus-)
 tee, Plaintiff.)
 vs.)

In Equity
 Consolidated Cause
 No. S-125-J.

RICHFIELD OIL COMPANY OF)
 CALIFORNIA, a corporation, and)
 WILLIAM McDUFFIE, as Re-)
 ceiver of Richfield Oil Company of)
 California, a corporation,)
 Defendant.)

UNIVERSAL CONSOLIDATED)
 OIL COMPANY, a California cor-)
 poration, Intervener.)
)

PIERCE WORKS, of the firm of O'Melveny, Tuller & Myers, appearing at this time for and on behalf of plaintiff Security-First National Bank of Los Angeles, a national banking association, as trustee; George Armsby, F. S. Baer, Harry J. Bauer, Stanton Griffis, Robert E. Hunter and Albert E. Van Court, constituting the Richfield Bondholders' Committee, a committee formerly and at the time of the filing of the claim of Richfield Bondholders' Committee herein referred to constituted of Nion R. Tucker, George Armsby, Stanton Griffis, Robert E. Hunter and Harry J. Bauer, interveners; First National Bank, Perryopolis, Pennsylvania, and Addie R. Boyd, and each of them, appeals in open court from that certain order, judgment and decree entered herein on September 26, 1934, adjudicating each, all and sundry the exceptions filed to the Report of the Honorable William A. Bowen, Special Master herein, with reference to the bill in intervention of Universal Consolidated Oil Company, which said report was filed on May 26, 1933, and presents petition for appeal, assignments of error, and order allowing appeal, which order is allowed and signed by the Court fixing the cost bond thereon at \$500.00.

IN THE UNITED STATES DISTRICT COURT
FOR THE SOUTHERN DISTRICT OF
CALIFORNIA, CENTRAL DIVISION

In Equity Consolidated Cause
No. S-125-J

THE REPUBLIC SUPPLY COMPANY)
OF CALIFORNIA, a corporation,)

Plaintiff,)

vs.)

RICHFIELD OIL COMPANY OF CALI-)
FORNIA, a corporation,)

Defendant.)

SECURITY-FIRST NATIONAL BANK)
OF LOS ANGELES, a national banking as-)
sociation, as Trustee,)

Plaintiff,)

vs.)

RICHFIELD OIL COMPANY OF CALI-)
FORNIA, a corporation, and WILLIAM C.)
McDUFFIE, as Receiver of Richfield Oil)
Company of California, a corporation,)

Defendants.)

UNIVERSAL CONSOLIDATED OIL)
COMPANY, a California corporation,)

Intervenor.)

SECURITY-FIRST NATIONAL BANK)
 OF LOS ANGELES, a national banking asso-)
 ciation, as Trustee, GEORGE ARMSBY, F.)
 S. BAER, HARRY J. BAUER, STANTON)
 GRIFFIS, ROBERT E. HUNTER and AL-)
 BERT E. VAN COURT, constituting the)
 Richfield Bondholders' Committee, et al.,)

Appellants in No. 1,)

vs.)

CHASE NATIONAL BANK OF THE)
 CITY OF NEW YORK, a national banking)
 association, et al.,)

Appellees in No. 1.)

SECURITY-FIRST NATIONAL BANK)
 OF LOS ANGELES, a national banking asso-)
 ciation, as Trustee, GEORGE ARMSBY, F.)
 S. BAER, HARRY J. BAUER, STANTON)
 GRIFFIS, ROBERT E. HUNTER and AL-)
 BERT E. VAN COURT, constituting the)
 Richfield Bondholders' Committee, et al.,)

Appellants in No. 2,)

vs.)

CHASE NATIONAL BANK OF THE)
 CITY OF NEW YORK, a national banking)
 association, et al.,)

Appellees in No. 2.)

UNIVERSAL CONSOLIDATED OIL))
COMPANY, a California corporation,))
)
Appellant in No. 3,))
)
vs.))
)
SECURITY-FIRST NATIONAL BANK))
OF LOS ANGELES, a national banking asso-))
ciation, et al.,))
)
Appellees in No. 3.))
_____))

AGREED STATEMENT OF CASE PURSUANT TO EQUITY RULE 77 UPON APPEALS FROM ORDERS DATED SEPTEMBER 17 AND SEPTEMBER 26, 1934 MADE BY THE UNITED STATES DISTRICT COURT FOR THE SOUTHERN DISTRICT OF CALIFORNIA, CENTRAL DIVISION.

Pursuant to the terms of Equity Rule 77, the parties hereto, believing that the questions presented by the appeal herein of Security-First National Bank of Los Angeles, a national banking association, as Trustee, George Armsby, F. S. Baer, Harry J. Bauer, Stanton Griffis, Robert E. Hunter and Albert E. Van Court, constituting the Richfield Bondholders' Committee, the Committee formerly and at the time of the filing of the claim of Richfield Bondholders' Committee herein consisted of Nion R. Tucker, George Armsby, Stanton Griffis, Robert E. Hunter and Harry J. Bauer, from the order and decree rendered in the trial court in this cause on the 17th day of September,

1934 (designated herein for convenience Appeal No. 1), and the appeal of said parties from the order and decree rendered in the trial court in this cause on September 26, 1934 (designated herein for convenience Appeal No. 2), and the appeal of Universal Consolidated Oil Company from said order and decree of September 26, 1934 (designated herein for convenience Appeal No. 3), can be determined by the United States Circuit Court of Appeals for the Ninth Circuit, to which said appeals have been allowed, without an examination of all the pleadings and evidence, present this statement of the case, showing how the questions arose and were decided in said United States District Court, and setting forth such of the facts alleged and proved, or sought to be proved, as are deemed essential to a decision of such questions by said United States Circuit Court of Appeals, as follows:

CREDITOR'S ACTION FOR APPOINTMENT OF RECEIVER

On January 15, 1931, The Republic Supply Company of California, a California corporation, as plaintiff, instituted an action in the United States District Court for the Southern District of California, Central Division, against Richfield Oil Company of California, a Delaware corporation, as defendant, which cause is known as No. S-125-J; and in its complaint it alleged that the defendant was indebted to it in the sum of \$282,909.77 upon an unsecured open book account for goods, wares and merchandise; and said plaintiff further alleged that the defendant was largely indebted, and had not the money necessary to meet its obligations then due and which would shortly thereafter become due; that the defendant's creditors were

pressing for payment and there was danger that some of such creditors might bring suits, levy attachments and issue executions upon the property of the defendant, with the consequence that the defendant would be forced to cease the conduct of its business, and that its assets would be sacrificed, and that such action would cause a great and irreparable loss and injury to the plaintiff and to the defendant; and praying that the Court administer the property and assets of Richfield Oil Company of California in accordance with the rights, equities, liens and priorities, if any, existing therein, and ascertain, decree and determine the rights of the plaintiff and of other creditors of the defendant, and for the purpose of preserving intact the property and assets of the defendant that a receiver or receivers be appointed of all of its properties and assets.

On January 15, 1931, the defendant filed its answer, admitting each and every allegation of the petition, and joining in the prayer thereof, including the prayer for the appointment of a receiver.

ORDER APPOINTING RECEIVER

Thereupon the Court, having jurisdiction of said cause, entered an order, on January 15, 1931, appointing William C. McDuffie as Receiver of all the property and assets of Richfield Oil Company of California, real, personal and mixed, of whatsoever kind and description, within the jurisdiction of the Court. The Receiver so appointed duly qualified as such and thereupon, under and by virtue of the authority of said order, duly entered and took possession of all of the properties and assets of Richfield Oil Company of California of every kind and description em-

braced in and covered by said order, and ever since has continued to hold possession thereof and to operate said properties.

ORDER DIRECTING CREDITORS TO FILE CLAIMS .

That subsequent to the appointment and qualification of William C. McDuffie as Receiver an order was made and entered by the Court on February 11, 1931, to the effect that all persons having or asserting any claim or demand against Richfield Oil Company of California were directed and required, before a day named, to file the same with William C. McDuffie, Receiver, at his office in the City of Los Angeles, California, each of said claims or demands to be supported by an affidavit on behalf of the claimant, setting out the amount and nature of any lien or other security held by the claimant, and also any claim to preference in payment from the receivership estate over any other creditors of said Richfield Oil Company of California; and further providing that all persons failing to so present their claims or demands might be enjoined from thereafter asserting or enforcing any such claim or demand against the Receiver or said Richfield Oil Company of California, or against its assets or the proceeds of any assets of said Receiver or said Richfield Oil Company of California. That pursuant to said order, and within the time therein set forth, Universal Consolidated Oil Company filed its claim with the Receiver, being Claim No. 4622 as follows:

“In the District Court of the United States for the
Southern District of California
Central Division

	— — — —	
The Republic Supply Company of))	#4622
California, a corporation,))	
)	IN EQUITY
Complainant,))	
)	No. S-125-J
-vs-))	
)	CLAIM OF
Richfield Oil Company of Califor-))	UNIVERSAL
nia, a corporation,))	CONSOLIDATED
)	OIL COMPANY
Defendant.))	
)	
	— — — —	

TO WILLIAM C. McDUFFIE, Receiver of and for the
assets of Richfield Oil Company of California, and
TO RICHFIELD OIL COMPANY OF CALIFORNIA,
a corporation:

Universal Consolidated Oil Company, a California corporation, by and through its officers duly authorized by resolution of its Board of Directors, herewith presents its demand and claim against Richfield Oil Company of California for money and materials in the amount of \$1,184,949.33 taken, withdrawn and withheld by Richfield Oil Company of California from claimant as is hereinafter set forth and at such times, amounts and items as is shown by the attached statement setting out such items and amounts, which statement is marked exhibit “A” and

made a part hereof. Claimant further makes a claim for interest at the rate of 7% per annum upon all claimant's funds, including both money and proper valuation of materials taken by the Richfield Oil Company of California, from the time of taking to the restoration thereof. That there are no offsets or counter-claims to the above stated amount representing such money and materials.

That claimant stands in the relation of a beneficiary of a trust and as such takes preference over all creditors of the Richfield Oil Company of California for the full amount of such demand and interest upon the following grounds:

That at a date prior to November 11th, 1929, Richfield Oil Company of California began acquiring the control of the subscribed and issued capital stock of claimant and on or about the month of June, 1930 acquired the controlling interest of claimant's subscribed and issued capital stock. That Richfield Oil Company of California ever since June, 1930 has been and now is the owner of the controlling interest of claimant's subscribed and issued capital stock; to-wit, approximately 52% thereof.

That at all times subsequent to the 11th day of November, 1929 Richfield Oil Company of California, by virtue of its stock ownership in claimant, actively and completely controlled the claimant's Board of Directors and officers and caused to be elected upon claimant's Board of Directors and as claimant's officers, directors and officers who were common to Richfield Oil Company of California. That due to such stock ownership and representation upon claimant's Board of Directors by directors common with Richfield Oil Company of California, and of such officers of claimant which were

common to Richfield Oil Company of California, Richfield Oil Company of California could and did maintain absolute domination and control of claimant and of its assets and acted and treated claimant's assets as though they formed a portion of the assets of Richfield Oil Company of California.

That the advances made by claimant either by way of cash or materials as shown by the attached account totaled the sum of \$2,585,765.67. That none of these advances were authorized by claimant's Board of Directors and were without its knowledge or consent. That Richfield Oil Company of California, through its domination of the affairs and business of claimant as aforesaid, withdrew from claimant in money and property the sum of \$2,585,765.67, none of which it has returned except the sum of \$1,400,816.34, leaving a balance of \$1,184,949.33 withheld and unreturned.

Claimant is informed and believes, and upon such information and belief alleges, that Richfield Oil Company of California was at all times subsequent to November 11th, 1929 insolvent and that Richfield Oil Company of California abstracted, received and held the said materials and money knowing that it was insolvent. That no notes or other evidences of indebtedness were given or received for such money or materials and claimant received no securities because thereof. That such acts upon the part of Richfield Oil Company of California were unauthorized and harmful to claimant and its stockholders other than Richfield Oil Company of California, and Richfield Oil Company of California thereby became and is charged as a trustee for the benefit of claimant and its stockholders other than Richfield Oil Company of California, to the full amount of all advances so made whether money or materials.

That claimant is informed and believes, and upon such information and belief alleges, that by reference to the books and records of Richfield Oil Company of California, part or all of such money and materials can be traced into certain specific property purchased by Richfield Oil Company of California with the said money and/or materials or the proceeds thereof, and that as to all such property claimant is entitled to have a lien upon and a preference to the property and from the proceeds thereof for the full amount of money and materials obtained by Richfield Oil Company of California from claimant as aforesaid prior to and preferred to all other creditors of Richfield Oil Company of California. That as to any amounts, whether of money or materials or the proceeds thereof, acquired by Richfield Oil Company of California from claimant as aforesaid and which cannot be traced into specific property now owned by Richfield Oil Company of California, and from which property claimant shall receive full reimbursement for the amounts so traced, claimant is entitled upon any dividend or disbursement from the general assets of Richfield Oil Company of California to claimant to have the full amount paid and disbursed applied solely to the benefit of claimant and its stockholders other than Richfield Oil Company of California, and for this purpose, to have any dividends and disbursements payable to claimant increased over that paid to other creditors of the Richfield Oil Company of California to such extent and so that Richfield Oil Company of California shall not be enriched and benefited as a stockholder of claimant through its own wrongful acts and the other creditors of Richfield Oil Company of California thereby receive a greater proportionate dividend than claimant.

This claim is filed without waiving any rights in law or equity which claimant may have by way of set-off or otherwise on account of any dividend or dividends or payment from funds now on hand or that may arise and are declared upon the stock of claimant owned by Richfield Oil Company of California.

Claimant further makes claim to an additional and contingent amount, the exact total of which it is unable to state at this time but which, from the best information, will approximate the sum of \$50,210.50. That this amount arises from the following circumstances:— That in the offsets allowed Richfield Oil Company of California set forth in the statement hereto attached appear certain items for materials furnished claimant by Richfield Oil Company of California. That as to certain of this material the persons who sold the same are now attempting to hold claimant responsible therefor. That one suit with regard to a portion of such material has already been filed against Universal Consolidated Oil Company in this regard by The Republic Supply Company of California in the Superior Court of the State of California, in and for the County of Kern, and is for the sum of \$21,324.11, together with costs and interest, and wherein the plaintiff is attempting to foreclose an alleged mechanic's lien upon certain real property of claimant. That claimant is informed and believes and upon such information and belief alleges that other suits will be instituted against claimant for other amounts. That claimant presents a claim for the amounts, if any, it may be compelled to pay because of such material and suits brought or which may be brought against claimant because thereof. That claimant will be compelled to defend such suits and further presents a claim for any

attorneys' fees which claimant will be compelled to expend in this connection.

Dated: April 15th, 1931.

UNIVERSAL CONSOLIDATED
OIL COMPANY

By R. E. STEARNS
Vice-President.

By L. E. LONG
Secretary.

(CORPORATE SEAL)

STATE OF CALIFORNIA)
) ss.
COUNTY OF LOS ANGELES)

L. E. LONG, Secretary of Universal Consolidated Oil Company, being first duly sworn, deposes and says: That I am the Secretary of Universal Consolidated Oil Company, the claimant in the foregoing claim, and that I make this verification for and on behalf of Universal Consolidated Oil Company; that I have read the foregoing claim and the same is true of my own knowledge except as to matters therein stated upon information and belief and as to those matter I believe it to be true.

L. E. LONG

Subscribed and sworn to before me this 15th day of April, 1931.

NORMAN F. SIMMONDS

Notary Public in and for the County of Los Angeles,
State of California.

(Notarial Seal)

My Commission Expires February 4th, 1933

EXHIBIT "A"

STATEMENT

RICHFIELD OIL COMPANY OF CALIFORNIA
IN ACCOUNT WITH UNIVERSAL CONSOLI-
DATED OIL COMPANY

DATE		DR.	CR.
1929			
Nov. 12	Cash	\$ 25,000.00	
" 13	"	750,000.00	
Dec. 31	Oil	1,008.08	
" 31	Office Furniture	101.00	
" 31	Drill Pipe and Casing	3,146.97	
" 31	Power	404.34	
1930			
Jan. 3	Cash	200,000.00	
" 31	Power	453.99	
" 31	Oil	1,029.91	
" 31	Insurance Claim	73.82	
" 31	Drill Pipe	2,002.92	
Feb. 15	Cash	500,000.00	
" 25	"	100,000.00	
" 27	"	100,000.00	
" 10	Revenue Stamps	85.00	
" 14	" "	104.00	
" 28	Oil	997.58	
" 28	Power	228.45	
" 28	Insurance Claim	35.60	
Mar. 7	Revenue Stamps	23.00	
" 31	Glass Top for desk	35.39	
" 31	Oil	1,021.47	
Apr. 30	Oil	1,141.65	
" 15	Cash	600,000.00	

May	31	Oil	1,150.00
June	6	Cash	75,000.00
"	10	"	28,000.00
"	17	"	5,000.00
"	30	Oil	2,012.07
"	30	Ice	31.90
July	31	Oil	1,023.57
"	31	Ice	11.00
Aug.	14	Cash	95,000.00
"	31	Ice	9.00
"	31	Oil	22,692.83
"	31	Gas and Gasoline	1,175.53
"	31	Drill Pipe	3,571.22
"	31	Sloan Lease operating expense	176.12
Sept.	30	Oil	17,213.30
"	30	Gas and Gasoline	1,183.84
"	30	Ice	1.00
"	30	Power	136.22
Oct.	31	Oil	14,012.23
"	31	Gas and Gasoline	851.23
"	31	Revenue Stamps	8.30
"	31	Sloan Lease operating expense	357.58
"	31	Electric Motor	1,016.12
Nov.	30	Oil	9,723.49
"	30	Gas and Gasoline	514.49
"	30	Labor	573.12
"	30	Sloan Lease operating expense	332.57

Carried forward 2,567,670.10

DATE		DR.	CR.
1930 Cont'd			
	Brought forward	2,567,670.10	
Dec.	31	Oil	9,735.48
"	31	Gas & Gasoline	577.11
"	31	Sloan Lease operating expense	673.94
1931			
Jan.	14	Oil	4,136.50
"	14	Power	808.69
"	14	Tubing	1,840.09
"	14	Gas and Gasoline	131.31
"	14	Sloan Lease operating expense	192.45
1929			
Dec.	31	By Check	101.00
"	31	" Field Material	8,470.25
"	31	" Check	260.26
1930			
Jan.	3	By Check	1,879.16
"	16	" "	144.08
"	21	" "	1,088.08
Feb.	15	" "	85.00
"	17	" "	100,000.00
Mar.	3	" "	1,029.91
"	11	" "	23.00
"	31	" Field Material	4,018.31
"	31	" Compensation Insurance	3,988.61
"	3	" Check	453.99
"	28	" "	228.45
Apr.	1	" "	997.58
"	15	" "	600,000.00
"	30	" Compensation Insurance	707.07

	“	30	“ Auto Insurance	68.95
	“	30	“ Field Material	3,447.87
May	31		“ Compensation Insurance	811.53
	“	31	“ Field Material	4,644.13
June	30		“ Compensation Insurance	876.20
	“	30	“ Field Material	8,696.52
July	15		“ Check	50,000.00
	“	18	“ “	37,000.00
	“	19	“ “	25,000.00
	“	25	“ “	20,000.00
	“	15	“ Dividend	91,316.50
	“	31	“ Compensation Insurance	1,116.35
	“	31	“ Field Material	20,703.73
Aug.	19		“ Check	40,000.00
	“	25	“ “	20,000.00
	“	31	“ Compensation Insurance	1,090.01
	“	31	“ Field Material	34,483.37
Sept.	3		“ Check	15,000.00
	“	10	“ “	20,000.00
	“	11	“ “	5,000.00
	“	18	“ “	15,000.00
	“	27	“ “	20,000.00
	“	30	“ Compensation Insurance	1,019.59
	“	30	“ Field Material	28,810.70
			Carried forward	2,585,765.67
				1,187,480.20

DATE		DR.	CR.
1930 Cont'd.			
	Brought forward	2,585,765.67	1,187,480.20
Oct. 2	By Check		15,000.00
" 11	" "		5,000.00
" 31	" Compensation		
	Insurance		795.06
" 31	" Field Material		60,854.22
Nov. 30	" Compensation		
	Insurance		786.79
" 30	" Field Material		16,886.93
Dec. 31	" Compensation		
	Insurance		923.46
" 31	" Field Material		97,946.70
1931			
Jan. 10	" Check		11,000.00
" 14	" Compensation		
	Insurance		326.80
" 14	" Field Material		3,816.18
	Balance Due Universal		
	Consolidated Oil Company		1,184,949.33
	TOTALS	<u>\$2,585,765.67</u>	<u>2,585,765.67"</u>

ORDERS APPOINTING SPECIAL MASTER
TO HEAR CLAIMS

That thereafter, on September 2, 1931, William A. Bowen, Esq., was appointed Special Master in said cause to hear proof and report to the Court concerning the allowance or rejection of any and all claims and demands which had theretofore been rejected by the Receiver in whole or in part, and concerning the allowance or rejection of any and all claims or demands to which answers or objections were filed, and concerning any and all questions of lien, preference or priority as between creditors or classifications of creditors; and further providing that said Special Master should make and file his report concerning the various matters committed to him.

And thereafter, by a further order under date of October 24, 1931, the said Special Master, William A. Bowen, was directed to report to the Court, after making all needed computations, his findings of fact and conclusions of law, together with transcripts of the proceedings, for the advisement of the Court; but providing that nothing in said order or orders should be construed as meaning that the Special Master's findings of fact should be final, but only that he should find the facts, for the purpose of aiding the Court, and make his recommendation.

BILL OF COMPLAINT OF SECURITY-FIRST
NATIONAL BANK OF LOS ANGELES TO
FORECLOSE TRUST INDENTURE.

Richfield Oil Company of California, as of May 1, 1929, issued and sold for cash \$25,000,000 aggregate principal amount of its First Mortgage and Collateral Trust Gold Bonds, Series A, 6% Convertible, which bonds were issued under and secured by a trust indenture dated May 1, 1929, to Security-First National Bank of Los Angeles, as Trustee.

There are now issued and outstanding bonds of said issue in the aggregate principal amount of \$24,981,000.00 together with unpaid coupons maturing on and after May 1, 1931.

The trust indenture securing said bonds constitutes a lien upon the interest of Richfield in the properties involved in this appeal (hereinafter described in Schedule B of the Statement of Evidence), but it is stipulated that any lien upon the interest of Richfield in said properties established by Universal Consolidated Oil Company is prior to the lien of said trust indenture.

Pursuant to leave of the trial court first had and obtained, Security-First National Bank of Los Angeles, as Trustee under said trust indenture, on July 28, 1932 filed in the Trial Court its bill of complaint, in Cause No. X-63-J, against Richfield Oil Company of California and William C. McDuffie as Receiver of Richfield Oil Company of California to foreclose said trust indenture, which fore-

closure action is now pending. Thereafter and on July 28, 1932, said foreclosure action was consolidated by order of the trial court with the above mentioned receivership cause, No. S-125-J.

Each of the following is a party to said consolidated cause: Unsecured Creditors Protective Committee—Richfield Oil Company of California, The Chase National Bank of the City of New York, Bank of America, Pan American Petroleum Company, William C. McDuffie as Receiver of Pan American Petroleum Company, Cities Service Company, Pan American Petroleum Company Bondholders' Committee, United States of America, Richfield-Pan American Reorganization Committee, Security-First National Bank of Los Angeles in its individual capacity, Pacific American Company, American Company, Manufacturers Trust Company of New York, Citizens National Trust & Savings Bank of Los Angeles, First National Bank and Trust Company of Seattle, Continental-Illinois Bank and Trust Company, The First National Bank of Chicago, Chemical National Bank and Trust Company, and California Bank.

BILL IN INTERVENTION OF UNIVERSAL
CONSOLIDATED OIL COMPANY AND AN-
SWERS.

Pursuant to leave of the trial court first had and obtained, Universal Consolidated Oil Company filed its bill in intervention in the above entitled cause on August 18, 1932, which bill in intervention is as follows:

“District Court of the United States in and for the
Southern District of California Central Division

Security First National Bank of Los Angeles, as Trustee,	(
)	
	Plaintiff,)
vs.)	
	(In Equity S-125-J
Richfield Oil Company of California,)	
a corporation, William C. McDuffie,	(
as Receiver of Richfield Oil Company)	
of California,	(
	Defendants.)
Universal Consolidated Oil Company,)	
	(
	Intervenor.)

BILL IN INTERVENTION OF UNIVERSAL
CONSOLIDATED OIL COMPANY

To the Honorable Judges of the District Court of the
United States, Southern District of California:

Universal Consolidated Oil Company files its bill of complaint in intervention against the Security First National Bank of Los Angeles, as trustee, Richfield Oil Company of California, and William C. McDuffie, as receiver of Richfield Oil Company of California, and respectfully shows:

I.

That Universal Consolidated Oil Company is and at all times herein mentioned was a corporation duly organized and existing under and by virtue of the laws of the State of California, having its principal office and place of busi-

ness in the City of Los Angeles, County of Los Angeles, State of California, a citizen of California and a resident and inhabitant of the Southern District of California.

II.

That the defendant Richfield Oil Company of California is and at all times herein mentioned was a corporation duly organized and existing under and by virtue of the laws of the State of Delaware, a citizen of said state and a resident and inhabitant of the District of Delaware, and its principal operating and general offices are in the City of Los Angeles, County of Los Angeles, State of California, within said Southern District of California. That the Security First National Bank of Los Angeles is now and at all times herein mentioned was, a national banking association organized and existing under the laws of the United States of America, and doing a banking business in the State of California, with its principal place of business in the County of Los Angeles, State of California.

III.

That heretofore, and on or about January 15, 1931, The Republic Supply Company of California, a corporation, filed its complaint before the above entitled Court, against the defendant, Richfield Oil Company of California, being an action in Equity, entitled No. S-125-J, to which bill and the allegations thereof, reference is hereby made for the further particulars thereof. That upon the filing of said bill of complaint by said The Republic Supply Company of California, said defendant, Richfield Oil Company of California entered its appearance, admitted that the allegations and each of them contained in said bill of complaint were true, consented to the relief prayed for in said bill of complaint, and prayed that the relief prayed

for in said bill of complaint be granted; thereupon, and on or about February 15, 1931, such proceedings were had that an order was made and entered by this Court, which order, among other things, appointed William C. McDuffie receiver of all the property, assets and business owned by or under the control or in the possession of said Richfield Oil Company of California, real, personal and mixed, of whatsoever kind and description, to which order reference is hereby made for the full particulars thereof. That the property, assets and business of which said William C. McDuffie was appointed the receiver as aforesaid, included all of the property set forth in "Exhibit A" hereto attached and made a part hereof, and all of which said property is held in trust by the said William C. McDuffie for the benefit of the intervenor, Universal Consolidated Oil Company, and subject to the prior lien of said Universal Consolidated Oil Company, as hereinafter set forth.

IV.

That at all times between October 1, 1929, and July 1, 1930, the said Richfield Oil Company of California actively and completely controlled the officers and a majority of the board of directors of the Universal Consolidated Oil Company, and the said Richfield Oil Company of California caused the board of directors of Universal Consolidated Oil Company to authorize certain persons who were officers and agents of Richfield Oil Company of California to draw checks upon the banks in which the moneys of Universal Oil Company were deposited.

That between October 1, 1929, and June 7, 1930, the defendant, Richfield Oil Company of California, without the knowledge or approval of the Universal Consolidated Oil Company, or of its board of directors, converted for

its own use and benefit from the said Universal Consolidated Oil Company one million seven hundred thousand dollars (\$1,700,000.) of cash belonging to said Universal Consolidated Oil Company, and deposited said cash in the account of the Richfield Oil Company of California in the Security First National Bank of Los Angeles, and commingled same with the funds of the Richfield Oil Company of California; that the Richfield Oil Company of California at no time gave to the Universal Consolidated Oil Company any promissory note or notes agreeing to repay said money, or any other evidence indicating that it owed any money to the Universal Consolidated Oil Company; that the board of directors of the Universal Consolidated Oil Company did not at any time authorize the loaning of said money or any part thereof to the Richfield Oil Company of California; that neither the whole nor any part of said sum has been returned or repaid by defendant Richfield Oil Company of California or by defendant, William C. McDuffie to the Universal Consolidated Oil Company.

V.

That between November 1, 1929, and January 14, 1931, the Richfield Oil Company of California acquired certain property and assets which have passed into the hands of the defendant, William C. McDuffie, receiver of and for the assets of said Richfield Oil Company of California, and which said property and assets were paid for in whole or in part by funds converted by the Richfield Oil Company of California from the funds of the Universal Consolidated Oil Company as hereinabove alleged. That attached hereto, marked "Exhibit A", hereby referred to and made a part hereof to all intents and purposes as

though set forth herein at length, is a list of the property and assets paid for in whole or in part with funds taken from the Universal Consolidated Oil Company by Richfield Oil Company of California.

Petitioner alleges that it is entitled to have a prior lien upon and a preference to each asset set forth in said Exhibit A and to the proceeds thereof, for the amount of the funds of the Universal Consolidated Oil Company taken by Richfield Oil Company of California and converted to its own use and used in the purchase and acquisition of said asset which amounts are set forth in said Exhibit A opposite the description of each asset therein described, and petitioner alleges that all of said assets set forth in Exhibit A are held by the defendant William C. McDuffie, receiver of and for the assets of the Richfield Oil Company of California, as trustee, in trust for the benefit of petitioner, Universal Consolidated Oil Company. That all of said assets so acquired and paid for in whole or in part with the funds of the Universal Consolidated Oil Company were acquired subsequent to the execution and delivery by Richfield Oil Company of California to plaintiff of the mortgage or trust indenture referred to in plaintiff's bill of complaint.

VI.

Petitioner alleges that the Security First National Bank of Los Angeles heretofore filed its bill of complaint in the above entitled action to foreclose a mortgage and trust indenture of the Richfield Oil Company of California of date May 1, 1929, securing an authorized bonded indebtedness in the aggregate principal amount of seventy-five million dollars (\$75,000,000.00.) which said mortgage and trust indenture purports to be a mortgage and lien upon

all of the assets and properties of the Richfield Oil Company of California, including all of the assets set forth in Exhibit A hereto attached. Petitioner alleges that the defendant, Richfield Oil Company of California has issued and outstanding, First Mortgage Bonds secured by the aforesaid trust indenture and mortgage, in an amount in excess of twenty-four million dollars (\$24,000,000.). Petitioner alleges that the said defendant Richfield Oil Company of California has defaulted under the aforesaid trust indenture and mortgage, and that the said Security First National Bank of Los Angeles, as trustee under said trust indenture and mortgage, has declared said default and has instituted the above entitled proceeding for the purpose of having said trust indenture and mortgage, of date May 1, 1929, declared a valid and subsisting first lien and charge upon all of the properties and assets of the Richfield Oil Company of California, including all of the assets set forth in Exhibit A hereto attached, prior and superior to the interests and liens and claims of all persons whatsoever, including petitioner; that the said Security First National Bank of Los Angeles, in its said bill of complaint, further requests that all of said property and assets of the Richfield Oil Company of California, including the assets set forth in Exhibit A hereto attached, be sold, and that such sale may be made absolute and without any right of redemption on the part of any person whatsoever, and that the proper deed or deeds and other instruments of conveyance be delivered to the purchaser or purchasers under said foreclosure sale.

VII.

Petitioner alleges that if all or any of the assets set forth in Exhibit A hereto attached are sold free from the lien and claim of your petitioner as prayed for by the said Security First National Bank of Los Angeles in its complaint hereinbefore referred to, your petitioner will be deprived of the lien and claim which it has upon all of the assets set forth in said Exhibit A, and your petitioner alleges that its lien and claim upon each and all of the assets set forth in Exhibit A is superior to and prior to the lien and claim of the said Security First National Bank of Los Angeles, as trustee under said mortgage and trust indenture of the Richfield Oil Company of California of date May 1, 1929. Petitioner alleges that if the property and assets of the Richfield Oil Company of California are sold under the foreclosure of said trust deed and mortgage, of date May 1, 1929, free and discharged of the lien and claim of your petitioner, there will be no assets remaining in the hands of William C. McDuffie, receiver of the Richfield Oil Company of California, with which to pay either in whole or in part the claim of your petitioner.

Petitioner alleges that any sale of the assets of the Richfield Oil Company of California, as set forth in Exhibit A, should be made subject to the prior claim and lien of your petitioner in the sum of one million, seven hundred thousand dollars (\$1,700,000.00).

VIII.

That petitioner has no adequate relief at law, and the relief to which it is entitled can be granted only by a court of equity.

IX.

WHEREFORE, petitioner prays that this honorable court order, adjudge and decree that Universal Consolidated Oil Company has a lien on the assets set forth in the exhibit attached to this bill and marked "Exhibit A" to the extent of the amount set opposite the description of such asset in the attached exhibit prior and superior to the lien of the Security First National Bank of Los Angeles under the terms of the mortgage and trust indenture of Richfield Oil Company of California dated May 1, 1929, securing an authorized bonded indebtedness in the aggregate principal amount of seventy-five million dollars (\$75,000,000.), and prior and superior to the claims of William C. McDuffie, as receiver of Richfield Oil Company of California, and its creditors; that upon the sale of the property in accordance with a decree which may be entered by the court, and as prayed for by the Security First National Bank of Los Angeles, as trustee, that there be set apart and paid over to the Universal Consolidated Oil Company from each of the assets that may be sold which are set out and described in Exhibit A attached to this bill, the amount set opposite the description of said asset in said exhibit, and for such other and further relief as may to the court seem proper.

A. L. Weil

LeRoy M. Edwards

Attorneys for Universal Consolidated Oil Company

COUNTY OF LOS ANGELES.)
 (SS
 STATE OF CALIFORNIA,)

E. G. STARR, being by me first duly sworn, deposes and says:

That he is the Vice President of Universal Consolidated Oil Company, the Intervenor in the foregoing Bill in Intervention of Universal Consolidated Oil Company; that he has read the foregoing Bill in Intervention and knows the contents thereof; that the same is true of his own knowledge except as to the matters which are therein stated upon his information and belief and as to those matters that he believes them to be true.

E. G. Starr

SUBSCRIBED AND SWORN TO BEFORE ME
 This 17 day of August, 1932.

(Notarial Seal) Oscar C. Sattinger
 Notary Public in and for the County of Los Angeles,
 State of California

EXHIBIT A

Parcel 1

Service Station, Franklin Avenue and Vermont Avenue, Los Angeles, California, on real property described as follows: Lot 28 and North 1/2 of Lot 27, of Croake & McCain's Gem of Hollywood Tract, as per Map recorded in Book 6, page 28, of Maps, in the office of County Recorder, County of Los Angeles, State of California.

Amount paid	\$11,000.00
-------------	-------------

Parcel 2

Storage tank built by Western Pipe and Steel Company, at Rioco Refineries, Hynes, California.

Amount paid	\$506,906.19
-------------	--------------

Parcel 3

Steamship "KEKOSKEE."

Amount paid	\$68,843.50
-------------	-------------

Parcel 4

Steamship "LARRY DOHENY."

Amount paid	\$164,746.20
-------------	--------------

Parcel 5

Steamship "PAT DOHENY."

Amount paid	\$168,663.06
-------------	--------------

Parcel 6

Terminal and Marine site at Richmond, California, including real estate described as follows:

That certain real property situated in the City of Richmond, State of California, particularly described as follows:

Lot 7, Section 25, Township 1 North, Range 5 West, M. D. B. & M. as designated on Map entitled "Map No. 1 of Salt Marsh and Tide Lot Lands, situate in the County of Contra Costa, State of California, 1872" on file in the Office of Surveyor General, Sacramento, California.

Lot 11, Section 25, Township 1 North, Range 5 West, M. D. B. & M., as designated on Map entitled "Map 1 of Salt Marsh and Tide Lot Lands, situate in the County of Contra Costa, State of California, 1872," on file in the office of Surveyor General, Sacramento, California.

Lot No. 10, Section 25, Township 1 North, Range 5 West, M. D. B. & M., as designated on Map entitled "Map No. 1 of Salt Marsh and Tide Lot Lands, situate in the County of Contra Costa, State of California, 1872," on file in the Office of the Surveyor General, Sacramento, California.

Lot 44 as designated on map entitled "Map of San Pablo Rancho, accompanying and forming a part of the Final Report of the Referees in partition" which map was filed in the office of the Recorder of the County of Contra Costa, State of California, on March 5, 1894, containing 236.49 acres of land, more or less.

Lot 45 as designated on the map entitled, "Map of San Pablo Rancho, accompanying and forming a part of the

Final Report of the Referees in partition" which map was filed in the office of the Recorder of the County of Contra Costa, State of California, on March 5, 1894, containing 152.81 acres of land, more or less.

Lots 1 and 2 in Section 26 and Lot 32 in Section 23 and Lot 8 in Section 25, all in Township 1 North, Range 5 West, Mount Diablo Base and Meridian, as designated on the Map entitled "Map No. 1 of Salt Marsh and Tide Lands situate in the County of Contra Costa, State of California, 1872" containing 56.05 acres of land, more or less, and the original of which map is on file in the office of the Surveyor General of the State of California, Sacramento, California.

TOGETHER WITH all buildings, machinery and improvements of every kind and character situated thereon or connected therewith.

Amount paid	\$265,914.94
-------------	--------------

Parcel 7

Richville camp site, Long Beach, California, being that certain real property particularly described as follows:

A portion of the Rancho Los Serritos, as per map recorded in book 2, page 202 of patents, records of said county, described as follows: Beginning at a point on the southeasterly line of that certain parcel of land conveyed to the Los Angeles Terminal Railway Company by deed dated June 19, 1891 and recorded in book 732, page 184 of deeds, records of said county, said true point of beginning being more particularly described as follows: Commencing at the northwest corner of lot eight (8) of the American Colony tract, as per map recorded in book

19, pages 89 and 90, miscellaneous records of said county; thence along the northerly line of said lot eight (8) north 89° , $57'$ $25''$ each, eight hundred eighty-six and eighty-nine hundredths (886.89) feet; thence north 0° $2'$ $35''$ west, four hundred fifty-six and sixty-two hundredths (456.62) feet, to the true point of beginning; thence along the southerly line of that parcel of land deeded to the Los Angeles and Salt Lake Railroad Company, September 15, 1927, on a curve concave southeasterly, having a radius of four hundred fifty-one and seventy-three hundredths (451.73) feet, and a tangent bearing south 27° $25'$ $20''$ west, a distance of four hundred ninety-three and two hundredths (493.02) feet; thence following along said railroad property line, tangent to said curve north 89° $57'$ $25''$ east, a distance of one thousand one and fifty-five hundredths ((1,001.55) feet; thence south 0° $2'$ $35''$ east, hundredths (1,001.55) feet; thence south 0° $2'$ $35''$ east, six hundred sixty (660) feet to the northerly line of Wardlow Road, as heretofore deeded to the County of Los Angeles; thence north 89° $57'$ $25''$ west, along the northerly line of Wardlow Road, to the intersection with the easterly line of the parcel of land heretofore mentioned as having been deeded to the Los Angeles Terminal Railway Company, a distance of fifteen hundred thirty-seven and fifty-four hundredths (1,537.54) feet, more or less; thence following northeasterly along the easterly line of the property of the Los Angeles Terminal Railway Company, as above mentioned, on a curve concave northwesterly, having a radius of twenty-nine hundred four and nine-tenths (2,904.9) feet, a distance of three hundred seventy-nine and eighty-four hundredths (379.84) feet to a point where the tangent to the curve

bears south $14^{\circ} 43' 45''$ west; thence following along the said line of the Los Angeles Terminal Railway Company on a curve concave northwesterly, having a radius of fifty-seven hundred sixty-nine and sixty-five hundredths (5,769.65) feet, a distance of fifty-eight and fifty-six hundredths (58.56) feet to the true point of beginning, comprising an area of twenty-one and ten hundredths (21.10) acres, more or less.

EXCEPTING THEREFROM the east fifty (50) feet thereof reserved for roadway purposes. ALSO subject to rights-of-way, etc., of record.

Amount paid	\$15,825.00
-------------	-------------

Parcel 8

Riverside Boulevard and Sutterville Road property, at Sacramento, California, being all that real estate property situate in the County of Sacramento, State of California, described as follows:

Beginning at a point on the center line of Sutterville Road and the southerly limits of the City of Sacramento, located north $34^{\circ} 26\frac{1}{2}'$ west 3,716.53 feet from an iron bar, set December 7, 1929 by Drury Butler, County Surveyor of Sacramento County, as reestablishing the southeast corner of the northeast quarter of section 23, township 8 north, range 4 east Mount Diablo Base and Meridian, under authority of the statutes of 1905, page 102, and running thence south $39^{\circ} 08'$ west 20.12 feet to a 2" iron pipe; thence continue south $39^{\circ} 18'$ west 489.32 feet or a total distance of 509.44 feet to a 2" pipe; thence north $50^{\circ} 45'$ west 642.4 feet to a 2" iron pipe; thence continue north $50^{\circ} 45'$ west 184 feet or a total

distance of 826.4 feet to the low water mark on the easterly bank of the Sacramento River; thence up said river and following the low water mark thereof, the following courses and distances:

North $30^{\circ} 57'$ east 327.76 feet; north $26^{\circ} 27'$ east 70.72 feet to a point 80 feet southerly of the Sherburn property; thence south $68^{\circ} 28'$ east 178 feet to a point on the westerly line of the lands purchased by the City of Sacramento from A. M. Mull, from which point a pipe marking a corner of the Sherburn property bears north $33^{\circ} 45'$ east 80 feet and a pipe marking the northwest corner of block 156 of the town of Sutter bears north $33^{\circ} 45'$ east 80 feet and north $39^{\circ} 15'$ east 212.38 feet; thence along the westerly line of the said property to the center line of the Sutterville Road and the southerly limits of Sacramento; thence along the center line of said Sutterville Road and the southerly limits of said City the following courses and distances: South $57^{\circ} 16'$ east 168.15 feet south $64^{\circ} 59'$ east 559.81 feet to the point of beginning and containing 8.3 acres, excepting therefrom all that portion of said property which lies between the low water mark and the line of ordinary high water mark of the Sacramento River.

All that real property situate, lying and being in the County of Sacramento, State of California, known, designated and described as follows, to-wit:

A piece or parcel of land in section 23, township 8 north, range 4 east, M. D. B. & M., and being that portion of all the land of F. Lachenmeyer lying south of the Sutterville Road and west of the westerly right-of-way of the Southern Pacific Railroad Company's operated line to Isleton.

A piece or parcel of land in section 23, township 8 north, range 4 east, M. D. B. & M., and being that portion of all the land of F. Lachenmeyer lying south of Sutterville Road and east of the westerly right-of-way line of the Southern Pacific Railroad Company's operated line to Isleton.

Amount paid \$11,600.00

Parcel 9

Absorption plant and vapor recovery system, Watson plant, Los Angeles County, California, constructed by Fluor Construction Company.

Amount paid \$205,994.99

Parcel 10

Sludge burner located at Watson Refinery, Watson, California, built by J. T. Thorpe & Sons.

Amount paid \$13,139.01

Parcel 11

813 shares of the capital stock of Hydrogeneration Process Company (purchased from Hyro-Patents Co. and Standard I. G. Company).

Amount paid \$43,089.00

Parcel 12

133,033 shares of the common capital stock of Universal Consolidated Oil Company.

Amount paid \$277,604.27"

Thereafter Security First National Bank of Los Angeles filed its answer to said bill in intervention of Universal Consolidated Oil Company, which answer is as follows:

“In the District Court of the United States
Southern District of California
Central Division

Security-First National Bank of)
Los Angeles, a national banking)
association, as Trustee,)
)
Plaintiff,)

vs.)

Richfield Oil Company of Cali-)
fornia, a corporation, William C.)
McDuffie, as Receiver of Rich-)
field Oil Company of California,)
)
Defendants.)

In Equity
No. S-125-J

ANSWER OF
SECURITY-
FIRST

Universal Consolidated Oil Com-)
pany, a corporation,)
)
Intervenor,)

NATIONAL
BANK OF LOS
ANGELES, AS
TRUSTEE, TO
BILL IN
INTERVENTION
OF UNIVERSAL
CONSOLIDATED
OIL COMPANY.

vs.)

Security-First National Bank of)
Los Angeles, a national banking)
association, as Trustee, Richfield)
Oil Company of California, a cor-)

poration, and William C. McDuffie, as Receiver of Richfield Oil Company of California,)
 Defendants in)
 Intervention.)
 _____)

TO THE HONORABLE JUDGES OF THE DISTRICT COURT OF THE UNITED STATES FOR THE SOUTHERN DISTRICT OF CALIFORNIA, CENTRAL DIVISION:

Now comes SECURITY-FIRST NATIONAL BANK OF LOS ANGELES, a national banking association, as trustee under the mortgage and trust indenture referred to in the bill of intervention herein, and answering said bill of intervention, admits, denies and alleges as follows:

1. Admits the allegations contained in Paragraphs I and II of said bill in intervention.

2. Answering Paragraph III of said bill, alleges that this defendant in intervention is without knowledge as to whether all or any of the property in said Paragraph III referred to is held in trust by William C. McDuffie either for the benefit of intervenor or subject to the prior or any lien of Universal Consolidated Oil Company, all as set forth in the bill of intervention herein, or otherwise, or at all. Otherwise admits the allegations of said Paragraph III.

3. Answering Paragraph IV of said bill, admits that between October 1, 1929 and June 7, 1930, cash aggregating or in excess of one million seven hundred thousand dollars (\$1,700,000.) was deposited by Richfield Oil Company of California in the Security-First National

Bank of Los Angeles and commingled with the funds of Richfield Oil Company of California. As to the various other matters and things in said paragraph alleged, and each of them, this defendant in intervention is without knowledge.

4. Answering Paragraph V of said bill, this defendant in intervention alleges that it is without knowledge as to the various matters and things in said paragraph alleged, or any of them.

5. This defendant in intervention admits the allegations contained in Paragraph VI of said bill.

6. Answering Paragraph VII of said bill, this defendant in intervention alleges that it is without knowledge of either the existence or the extent, if any, of the lien or claim in said paragraph referred to and alleges that it is likewise without knowledge as to each and all of the various matters and things in said paragraph alleged.

7. Answering Paragraph VIII of said bill, this defendant in intervention alleges that it is without knowledge as to the various matters and things, and each of them, in said paragraph alleged.

WHEREFORE, this defendant in intervention prays that intervenor herein take nothing and that defendant in intervention recover its costs herein incurred.

O'MELVENY, TULLER & MYERS
And PIERCE WORKS

Attorneys for Security-First National Bank of
of Los Angeles, as Trustee.

COUNTY OF LOS ANGELES)
) SS.
 STATE OF CALIFORNIA)

C. C. Hogan, being duly sworn, deposes and says: That the answering defendant in intervention in the within-entitled action is a national banking association, and that affiant is an officer thereof, to-wit, the Asst. Secretary, and makes this verification for and on behalf of said national banking association.

That affiant has read the foregoing answer of Security-First National Bank of Los Angeles, as Trustee, to bill in intervention of Universal Consolidated Oil Company and knows the contents thereof; that the same is true of his own knowledge, except as to matters therein stated on information or belief, and as to such matters he believes it to be true.

C C Hogan

Subscribed and sworn to before me this 26th day of November, 1932.

(Notarial Seal)

S Robertson

Notary Public in and for the County of Los Angeles,
 State of California."

Thereafter Richfield Oil Company of California and William C. McDuffie, as Receiver of Richfield Oil Company of California, filed an answer to said bill in intervention of Universal Consolidated Oil Company, which answer is as follows:

“In the District Court of the United States
Southern District of California
Central Division

Security First National Bank of))	
Los Angeles, as Trustee,))	
)	
Plaintiff,))	
)	
vs.))	In Equity S-125-J
)	
Richfield Oil Company of Cali-) ANSWER TO)	BILL IN
ifornia, a corporation, William C.))	INTERVENTION
McDuffie, as Receiver of Richfield))	OF UNIVERSAL
Oil Company of California,))	CONSOLIDATED
Defendants,))	OIL COMPANY.
)	
Universal Consolidated Oil Com-) .)	
pany,))	
)	
Intervenor.))	

To the Honorable Judges of the District Court of the United States, for the Southern District of California, Central Division:

Richfield Oil Company of California, a corporation, and William C. McDuffie, as Receiver of Richfield Oil Company of California, file their answer to the bill of complaint in intervention of Universal Consolidated Oil Company against Security-First National Bank of Los Angeles, as Trustee, Richfield Oil Company of California, and William C. McDuffie, as Receiver of Richfield Oil Company of California, and respectfully admit, deny and allege as follows:

I.

Answering Paragraph III of said bill in intervention of Universal Consolidated Oil Company, the defendants answering hereby do hereby deny that the property, assets and business or any of the property or assets or business of which said William C. McDuffie was appointed the receiver, as alleged in said bill in intervention, is held in trust or otherwise or at all by the said William C. McDuffie for the benefit of the intervenor, Universal Consolidated Oil Company, and subject to the prior lien or any lien of said Universal Consolidated Oil Company.

II.

Answering Paragraph IV of said bill in intervention of Universal Consolidated Oil Company, the defendants answering hereby do hereby deny that at all times or at any times between October 1, 1929, and July 1, 1930, or at any other time, or at all, the said Richfield Oil Company of California actively and completely or at all controlled the officers and a majority of the board of directors or any officer or any director of the Universal Consolidated Oil Company, and deny that the said Richfield Oil Company of California caused the board of directors of Universal Consolidated Oil Company to authorize certain persons who were officers and agents of Richfield Oil Company of California to draw checks upon the banks in which the moneys of Universal Consolidated Oil Company were deposited, and deny that between October 1, 1929, and June 7, 1930, or at any other time, the defendant Richfield Oil Company of California, either without the knowledge or authority or approval of Universal Consolidated Oil Company or of its board

of directors, or at all, converted for its own use and benefit or at all from the said Universal Consolidated Oil Company One Million Seven Hundred Thousand Dollars (\$1,700,000.00), or any other sum or sums whatsoever, belonging to said Universal Consolidated Oil Company, and deny that said amount of cash or any cash, or any sum or property whatsoever, belonging to said Universal Consolidated Oil Company was deposited in the account of Richfield Oil Company of California in the Security-First National Bank of Los Angeles or in any other bank and commingled with the funds of the Richfield Oil Company of California or used in any other manner whatsoever, and deny that the Richfield Oil Company of California did not give to Universal Consolidated Oil Company any evidence indicating that it owed any money to the Universal Consolidated Oil Company, and deny that the board of directors of the Universal Consolidated Oil Company did not at any time authorize the loaning of said money or any part thereof to the Richfield Oil Company of California, and deny that neither the whole nor any part of said sum has been returned or repaid by defendant Richfield Oil Company of California or by defendant William C. McDuffie, as Receiver of Richfield Oil Company of California, to the Universal Consolidated Oil Company; and in further answer to said Paragraph IV of said bill in intervention said defendants answering hereby do hereby allege that between November 13, 1929, and August 14, 1930, both dates inclusive, Universal Consolidated Oil Company loaned to Richfield Oil Company of California Two Million Four Hundred Forty-eight Thousand Dollars (\$2,448,000.00) by checks drawn on the bank accounts of Universal Consolidated Oil Company and signed on

behalf of Universal Consolidated Oil Company in each instance by L. E. Long, together with one of the following, to-wit: R. W. McKee, R. B. Charlesworth, or J. S. Wallace; that the proceeds of said loans were deposited by Richfield Oil Company of California in the account of the latter in the Security-First National Bank of Los Angeles and commingled with other funds of Richfield Oil Company of California in said account; that the amount of said loans was in each instance recorded on the books of Universal Consolidated Oil Company and of Richfield Oil Company of California and interest thereon was invoiced monthly to Richfield Oil Company of California by Universal Consolidated Oil Company, and by the time of the appointment of William C. McDuffie as Receiver of Richfield Oil Company of California, on January 15, 1931, the principal amount of said loans of Universal Consolidated Oil Company to Richfield Oil Company of California had been reduced to One Million One Hundred Eighty-three Thousand One Hundred Forty-eight and 23/100 Dollars (\$1,183,148.23) and the unpaid interest thereon had been reduced to Sixty-three Thousand Fifty-six and 93/100 Dollars (\$63,056.93), by payments in the following manner, recorded on the books of both companies, to-wit:

(a) Payment of Nine Hundred Seventy-three Thousand Dollars (\$973,000.00) upon the principal amount of said loans by checks drawn by Richfield Oil Company of California on its said account with Security-First National Bank of Los Angeles payable to the order of and cashed by Universal Consolidated Oil Company,

(b) Payment of Ninety-one Thousand Three Hundred Sixteen and 50/100 Dollars (\$91,316.50) upon the

principal amount of said loans by credit covering dividend of fifty cents (50¢) per share on one hundred eighty-two thousand six hundred thirty-three (182,633) shares of stock of Universal Consolidated Oil Company held by Richfield Oil Company of California,

(c) Payment of Two Hundred Thousand Five Hundred Thirty-five and 27/100 Dollars (\$200,535.27) upon the principal amount of said loans by monthly credits to Richfield Oil Company of California representing merchandise and services purchased for and furnished to Universal Consolidated Oil Company by Richfield Oil Company of California,

(d) Payment of One Thousand Eight Hundred Seventy-nine and 16/100 Dollars (\$1,879.16) upon the interest accrued upon said loans by check drawn by Richfield Oil Company of California on its said account with Security-First National Bank of Los Angeles payable to the order of and cashed by Universal Consolidated Oil Company;

that by reason of the foregoing Richfield Oil Company of California was indebted to Universal Consolidated Oil Company at January 15, 1931, in the amount of One Million Two Hundred Forty-six Thousand Two Hundred Five and 16/100 Dollars (\$1,246,205.16) on account of both principal and interest on said loans and continues so indebted.

III.

Answering Paragraph V of said bill in intervention of Universal Consolidated Oil Company, the defendants answering hereby do hereby deny that any property or assets acquired by Richfield Oil Company of California between November 1, 1929, and January 14, 1931, or at

any other time, which have passed into the hands of William C. McDuffie as Receiver of Richfield Oil Company of California, were paid for in whole or in part by funds of Universal Consolidated Oil Company either converted by Richfield Oil Company of California or otherwise, and deny that the property and assets appearing upon the list of property and assets marked Exhibit "A" attached to said bill in intervention and made a part thereof were paid for in whole or in part with funds taken from Universal Consolidated Oil Company by Richfield Oil Company of California or by funds belonging to Universal Consolidated Oil Company, and deny that Universal Consolidated Oil Company is entitled to have a prior lien or any lien upon or a preference to any property or assets in the possession of William C. McDuffie, as Receiver of Richfield Oil Company of California, or to the property and assets set forth in said list of properties and assets marked Exhibit "A" and attached to said bill in intervention or the proceeds thereof, for any amount whatsoever, and deny that said property and assets described in said Exhibit "A" to said bill in intervention herein or any other property and assets are held by the defendant William C. McDuffie, as Receiver of Richfield Oil Company of California, as trustee, in trust, for the benefit of Universal Consolidated Oil Company or in any other capacity for the benefit of Universal Consolidated Oil Company, but admit that all of the property and assets set forth on the list marked Exhibit "A" and attached to said bill in intervention were acquired by Richfield Oil Company of California subsequent to the execution and delivery by Richfield Oil Company of California to Security-First National Bank of Los Angeles of the mortgage or trust indenture referred to in the

bill of complaint filed herein by Security-First National Bank of Los Angeles, as Trustee, for foreclosure of such mortgage or deed of trust.

IV.

Answering Paragraph VII of said bill in intervention of Universal Consolidated Oil Company, the defendants answering hereby do hereby deny that Universal Consolidated Oil Company has any lien or claim of which it might be deprived if all or any of the assets set forth in Exhibit "A" to said bill in intervention are sold free from the alleged lien or claim of Universal Consolidated Oil Company, and deny that said Universal Consolidated Oil Company has any lien or claim upon each and all or any of the assets set forth in Exhibit "A" to said bill in intervention, either superior to and prior to the lien and claim of said Security-First National Bank of Los Angeles, as Trustee under said mortgage and trust indenture of Richfield Oil Company of California dated May 1, 1929, or at all, and deny that if the property and assets of Richfield Oil Company of California which are subject to said deed of trust and mortgage dated May 1, 1929, are sold under foreclosure of said deed of trust and mortgage, free and discharged of the alleged lien and claim of Universal Consolidated Oil Company, there will be no assets remaining in the hands of William C. McDuffie, as Receiver of Richfield Oil Company of California, with which to pay, either in whole or in part, the indebtedness of Richfield Oil Company of California to Universal Consolidated Oil Company, as hereinbefore set forth, and deny that any sale of the assets of Richfield Oil Company of California set forth in Exhibit "A" to said bill in intervention should be made subject

to the alleged claim and lien of Universal Consolidated Oil Company in the sum of One Million Seven Hundred Thousand Dollars (\$1,700,000.00), or in any other sum or amount whatsoever.

V.

Answering Paragraph VIII of said bill in intervention of Universal Consolidated Oil Company, the defendants answering hereby do hereby deny that said Universal Consolidated Oil Company has no adequate relief at law, and in further answer to said Paragraph VIII allege that said Universal Consolidated Oil Company has filed a proof of claim with William C. McDuffie, as Receiver of Richfield Oil Company of California, against Richfield Oil Company of California, in the stated amount of One Million One Hundred Eighty-four Thousand Nine Hundred Forty-nine and 33/100 Dollars (\$1,184,949.33) and an additional contingent claim of Fifty Thousand Two Hundred Ten and 50/100 Dollars (\$50,210.50), with interest on both sums at seven per cent (7%) per annum.

WHEREFORE, these defendants pray that said petition in intervention be referred to William A. Bowen, Special Master herein, to be heard at the same time as the said proof of claim of said Universal Consolidated Oil Company, and that upon the hearing before said Special Master the relief sought in said bill in intervention be denied to Universal Consolidated Oil Company and that Universal Consolidated Oil Company be allowed an unsecured non-preferred general claim against Richfield Oil Company of California in the receivership of the latter in the amount of One Million Two Hundred Forty-

six Thousand Two Hundred Five and 16/100 Dollars (\$1,246,205.16).

Dated: Los Angeles, California, November 15th, 1932.

GIBSON, DUNN & CRUTCHER

By HOMER D. CROTTY,

Solicitors for Richfield Oil Company of California and William C. McDuffie, as Receiver of Richfield Oil Company of California.

STATE OF CALIFORNIA)
) ss.
County of Los Angeles)

J. S. WALLACE, being by me first duly sworn, deposes and says: That he is the vice-president of Richfield Oil Company of California, a corporation, one of the Defendants in the foregoing Bill in Intervention of Universal Consolidated Oil Company, and knows the contents thereof; and that the same is true of his own knowledge, except as to the matters which are therein stated upon his information or belief, and as to those matters, that he believes it to be true.

J. S. WALLACE.

Subscribed and sworn to before me this 15th day of November, 1932.

RICHARD L. WALLACH,

Notary Public in and for said County and State.
My Commission Expires: Oct. 23, 1936.”

APPOINTMENT OF SPECIAL MASTER TO HEAR
THE ISSUES PRESENTED BY THE BILL IN
INTERVENTION OF UNIVERSAL CONSOLI-
DATED OIL COMPANY.

Pursuant to stipulation of the attorneys of record for Security-First National Bank of Los Angeles, as Trustee, and for Universal Consolidated Oil Company, and for Richfield Oil Company of California, and for William C. McDuffie, as Receiver of Richfield Oil Company of California, and on December 6th, 1932, William A. Bowen, Esq., was appointed Special Master to hear the issues presented by the bill in intervention of Universal Consolidated Oil Company, set forth above, and the answers thereto set forth above, which hearing was ordered to be consolidated with and held at the same time as the hearings upon the proof of claim filed by Universal Consolidated Oil Company hereinabove set forth, with the intent and purpose that said proof of claim and said bill in intervention be disposed of at a single hearing and that posed of jointly by said Special Master on the basis of all the issues presented by said bill in intervention be dis-said hearing.

STATEMENT OF EVIDENCE

Inasmuch as the evidence is without material dispute and certain of the facts which were controverted at the hearing before the Special Master and the trial court have been conceded upon appeal, it has been possible to condense to a great extent the evidence introduced before the trial court. The following statement, though not considered by witnesses, contains all of the evidence upon the

points in controversy in the appeals of the Security-First National Bank as trustee under the Richfield bond issue and the Universal Consolidated Oil Company.

It is admitted and agreed by all parties that Richfield Oil Company of California, after purchasing enough of the stock of Universal Consolidated Oil Company to obtain control of the board of directors of that corporation, thereupon but prior to January 15, 1931, misappropriated from Universal a net sum of \$1,625,000.00. It is also admitted that that misappropriation was such as to constitute Richfield the trustee of a constructive trust in which Universal was the beneficiary.

The only matter concerning which there is any controversy on these appeals relates to the question of whether or not Universal has sufficiently traced those trust funds into property purchased by Richfield from the bank account in which the trust funds had been commingled with other funds belonging to the trustee. Security-First National Bank of Los Angeles as trustee, contends that no part of the funds has been traced, while Universal contends that more than the amount awarded by the trial court was sufficiently traced into tangible property thus purchased.

The whole of the \$1,625,000.00 transferred from Universal to Richfield was deposited in installments by Richfield in its bank account at the Security-First National Bank of Los Angeles and there commingled with the moneys of Richfield. All of the properties and assets here involved were paid for in whole or in part by checks on said bank account.

The account in question was an ordinary commercial checking account. At the time of the first deposit of

Universal moneys, Richfield had a large balance in the account. That balance fluctuated from day to day as Richfield deposited and withdrew large sums of its own money in addition to the money of Universal. These deposits from sources other than Universal amounted to \$81,903,908.39 from November 13, 1929, to January 14, 1931.

However, the account of Richfield in the Security-First National Bank had been completely depleted on January 8, 1931, a week before the appointment of the receiver, and at the close of business on January 8, 1931, there existed an overdraft of \$18,080.18.

The evidence introduced by the parties relating to the tracing by Universal of its misappropriated moneys into the properties purchased by Richfield out of the bank account in which the funds had been commingled may best be set forth in the form of the summary (Schedule A) shown below.

Column one of the summary represents the date; column two, the deposits of Universal moneys in the Richfield account; column three, the daily closing balance of that account, in which is reflected all checks charged against the account and all deposits credited to the account during the day; column four, the lowest posted balances shown on the bank's books during any day between takings of Universal funds; column five, the lowest balance ascertained by deducting all checks cleared each day before crediting deposits made during the same day; and column six, the particular parcel upon which payments were made on the date indicated in column one and the amount paid on such parcel from said bank account. The materiality of the data set forth in columns

three, four and five will, of course, be made clear in the briefs so that no particular discussion in that regard is required here. The matter set forth in column four, however (the lowest daily posted balance), does require some explanation and this is best afforded by a brief reference to the evidence concerning the bookkeeping methods of the bank.

Security-First National Bank keeps its customers' accounts on bookkeeping machines. For the purpose of posting checks or deposits to the account of a customer, the ledger sheets are inserted in the machines and the items to be included in the account are posted therein. Before extracting the sheet from the machine it is necessary to place the balance on the ledger sheet. The results so obtained are what are referred to herein as the lowest posted balances. The number of those balances appearing in the Richfield account varied from three to seven or eight each day. That number would depend upon the number of times the bookkeeper went through his ledger. These lowest posted balances were never given to the depositor.

Checks come from the clearing house to the bank twice a day, the first clearing being at 8:15 A. M. and the second at 11:15 A. M. They are sorted each time and given to the various bookkeepers for posting. Checks that come in over the counter at the bank are given to the bookkeepers for posting as early as 10:30 in the morning, but sometimes not until 2:30 in the afternoon. The bookkeepers begin posting immediately, but it is up to them when they will post a particular check. They have until 2:30 P. M. to return to the clearing house any check on which the bank intends to refuse payment, and the bookkeeper in posting checks, pays no attention to the order

in which the checks are presented to the bank nor to the order in which deposits are made at the bank.

The books are kept on bookkeeping machines, and each time the ledger sheet of a particular depositor is placed in the machine for the purpose of posting checks or deposits or both, the balance in the account must be recorded before the ledger sheet can be removed from the machine. As heretofore stated, sometimes three and sometimes as many as seven or eight of these balances would appear on an account such as Richfield's during one day.

The balances that appear during the course of the day do not necessarily show all of the checks on that account that have come to the bank, or all of the deposits to that account that have been made up to the time that balance appeared, nor do they show the time of day when such balances were made, nor do they show the order in which deposits were made or the order in which checks are presented during the course of the day. It would be possible for other checks against the account to have been presented for payment and other deposits to have been made to the account prior to the time when the balance in question was taken. But those checks and deposits would not be reflected in the particular balance either because they had not been passed on to the bookkeeper for posting or because they were not included in the particular group of checks upon which the bookkeeper was working at the moment.

The chief clerk of the Security-First National Bank was asked how the bank would handle a situation in which two checks for \$100.00 apiece came to the bank in the morning's clearing at a time when the account on which they were drawn contained only \$100.00. He

answered that payment might be refused on either one of the checks as there was no rule to determine which would be paid.

When the facts were changed slightly so that it was assumed that one check for \$100.00 came through the clearing house at 8:15 in the morning, but before that check was posted in the ledger, another check for \$100.00 was presented at the counter, the witness stated that the check presented at the counter would be paid first and payment of the check that came through the clearing house would be refused, even though it had been in the bank first.

In the event that a certified check is presented, a somewhat different procedure is followed. As soon as it is certified, a pencil notation of that fact is made upon the ledger and the bookkeeper considers that fact in his handling of all subsequent checks that are brought to him for posting. Before certifying a check, the bank examines the ledger account of the depositor to see if it contains sufficient funds to cover the check. If the account does not contain sufficient funds, the bank will examine the deposits made to the account, including deposits that have not been posted. If there have been sufficient deposits during the day, the bank will certify the check even though these deposits are not reflected in the posted balance in the ledger account.

With the above explanation, we here set forth under the caption of "Schedule A," a summarization of the evidence. Schedule B contains a detailed description of the parcels or assets referred to simply by parcel numbers in column six of Schedule A.

SCHEDULE A

(1)	(2)	(3)	(4)	(5)	(6)
Date	Universal Deposits	Lowest Daily Closing Balances Between Takings of Universal Funds	Lowest Posted Balances Shown on Bank's Books During any Day Between Takings of Universal Funds	Lowest Balance Ascertained by Deducting from Opening Balance All Checks Cleared Each Day Before Crediting Deposits Made During the Same Day	Property on Which Pay- ments Were Made and Amount Paid on Such Property from said Bank Account
1929					
Nov 13	\$750,000.00				
" 19		\$272,704.61	\$209,198.80	\$ 93,635.65	
" 27			198,719.90		
" 29					
" 30					
" 30					
Dec 9					\$ 50,000.00 Parcel 5
" 23					44,540.00 Parcel 2
" 23					500.00 Parcel 1
" 23					35,421.75 Parcel 9
" 23					164,746.20 Parcel 8
" 23					168,663.06 Parcel 7
" 24					190,914.94 Parcel 6
				76,032.84 (red)	

"	31				49,385.00	Parcel	2
1930							
Jan	3				500.00	Parcel	1
"	3				50,000.00	Parcel	5
"	20	200,000.00					
"	23		466,764.36	466,764.36	336,646.20		
"	24				308,662.67		
"	27				500.00	Parcel	4
"	29				221,202.08	Parcel	10
"	29				50,000.00	Parcel	5
"	30				53,680.00	Parcel	2
"	30		464,148.47	462,088.47	500.00	Parcel	1
Feb	1		447,704.86	443,916.47			
"	15	500,000.00	(red)	172,136.10	222,642.41 (red)		
"	24		296,779.62	20,925.52	20,879.26		
"	25	100,000.00	252,760.24	122,941.84	128,412.10 (red)		
"	26			204,342.03	204,138.29		
"	27	100,000.00			272,948.76		

Mar	1			34,332.84	Parcel	3	104
"	1			48,000.00	Parcel	2	
"	4			239,919.57			
"	5			203,185.63		11	
"	6			17,400.43			
"	8						
"	10	209,201.80					
"	12		113,324.49				
"	18		53,259.91				
"	22			7,500.00	Parcel	1	
"	25			34,332.43	Parcel	3	
"	28			50,000.00	Parcel	2	
Apr	2			50,000.00	Parcel	5	
"	3			500.00	Parcel	1	
"	7			4,500.00	Parcel	4	
"	16		8,520.06				
"	21			34,332.43	Parcel	3	

SCHEDULE A (Continued)

(1)	(2)	(3)	(4)	(5)	(6)
1930					
Apr 26					Parcel 5
" 28					Parcel 2
May 5		\$140,878.03			825.00
Jun 6	\$ 75,000.00			\$ 114,164.03 (red)	
" 7		168,222.42			
" 18			\$ 69,303.89		
" 21				122,078.81 (red)	
" 25					Parcel 3
" 27			45,336.49		
" 28					Parcel 2
Jul 14				1,679,420.83 (red)	
" 15					Parcel 3
" 17					Parcel 5
" 31					Parcel 1

SCHEDULE B

Description of Properties Upon Which Liens Are
Claimed by Universal

PARCEL 1: Service Station located in the City of Los Angeles, County of Los Angeles, State of California, more particularly described as follows:

Lot twenty-eight (28) and the North half ($N\frac{1}{2}$) of Lot twenty-seven (27) of Croake & McCann's Gem of Hollywood Tract, as per map recorded in Book 6, page 28 of Maps in the Office of the County Recorder of Los Angeles County, known as the Franklin and Vermont Service Station.

PARCEL 2: 10 storage tanks, of which 5 are located on property known as the Hottenroth property adjoining the Rioco Refinery located at Long Beach, Los Angeles County, California, more particularly described as follows:

Lots twenty-four (24) and twenty-five (25) in Block 27 of the California Cooperative Colony Tract in the City of Long Beach, as per map recorded in Book 21, pages 15 and 16, of Miscellaneous records of Los Angeles County, California, excepting the west 30 feet thereof.

Five are located on property known as the Hunstock property adjoining said Rioco Refinery, and more particularly described as follows:

Lots 11, 12, 13, 14, 15, and 16 in Block 27, California Cooperative Colony Tract, except the east 30 feet thereof, conveyed to the Los Angeles Terminal Railway Company, as per map of said tract recorded in Book 21, at

pages 15 and 16, Miscellaneous Records in the office of the County Recorder of Los Angeles County.

PARCEL 3: Vapor Recovery Plant, located on the Watson Refinery site in Los Angeles County, California. (This Vapor Recovery Plant was constructed upon real property which was at the time of construction and now is, owned by Pan American Petroleum Company and subject to the trust indenture made by Pan American Petroleum Company to The Chase National Bank of New York and Bank of America as trustees to secure bonds of Pan American Petroleum Company.) More particularly described as follows:

Beginning at the North West corner of the land conveyed to the Pan American Petroleum Company by deed recorded in Book 1987 page 280 Official Records of said county in the easterly line of Wilmington Ave; thence along said easterly line north $34^{\circ} 16' 50''$ East 964.82 feet; thence south $88^{\circ} 55' 40''$ East 3240.90 feet to the westerly line of the tract of land conveyed to the Pan American Petroleum Company, by deed recorded in Book 2158 page 106 of said official records; thence along said westerly line south $17^{\circ} 09' 45''$ west 323.91 feet to the North Easterly corner of the first above described tract of land conveyed to said Pan American Petroleum Company; thence along the northerly line of said tract of land south $53^{\circ} 04' 15''$ west 805.68 feet; thence still along said Northerly line north $88^{\circ} 55' 40''$ west 3044.65 feet to the point of beginning. Containing sixty (60) acres of land.

PARCEL 4: Real property known as the Mull property, located on Riverside Blvd. and Sutterville Road in the City of Sacramento, County of Sacramento, State

of California. For a more complete description see Receiver's Exhibit "F".

PARCEL 5: Certain leaseholds known as the Delany Producing property, located in Los Angeles County, California. For a more complete description of said property see Receiver's Exhibit "F".

PARCEL 6: Certain real property located in the City of Richmond, County of Contra Costa, State of California, used as a terminal and marine site by Richfield Oil Co., together with all buildings, machinery and improvements of every kind and character situated thereon or connected therewith. For a more complete description of said property see Receiver's Exhibit "F".

PARCEL 7: American Steel Tanker Pat Doheny, registered from Los Angeles, California.

PARCEL 8: American Steel Tanker Larry Doheny, registered from Los Angeles, California.

PARCEL 9: American Steel Tanker Kekoskee, registered from Los Angeles, California, which at all times herein mentioned has been owned by Richfield Oil Company, a California corporation.

PARCEL 10: 106,000 shares of stock of Universal Consolidated Oil Company, represented by the following certificates issued to Richfield Oil Company of California: No. LX26, February 13, 1930, 42,500 shares; No. LX27, February 14, 1930, 50,000 shares; No. LX28, February 14, 1930, 2,000 shares; No. LX32, March 10, 1930, 11,500 shares.

PARCEL 11: 5,100 shares of stock of Universal Consolidated Oil Company, represented by the following certificate issued to Richfield Oil Company of California: No. LX31, March 7, 1930.

The foregoing constitutes a statement of all the evidence necessary to be considered in the determination of these appeals.

FINDINGS AND CONCLUSIONS OF SPECIAL MASTER.

I.

REPORT ON CLAIM.

On May 26, 1933, said Special Master filed in the District Court of the United States for the Southern District of California, Central Division, his findings and conclusions on the claim of Universal Consolidated Oil Company set forth above, which are as follows:

<u>"M's No.</u>	<u>R's No.</u>	<u>Claimant</u>	<u>Claimed</u>	<u>Allowed</u>
2637	4622	Universal Consolidated Oil Company	\$1,184,949.33 plus interest and \$50,210.50 (Estimated)	\$779,154.31 (subject to possible modification as below)

FINDINGS

Claim for \$1,184,949.33, plus interest, unpaid balance on an account between claimant and Richfield Oil Company of California, and for a contingent amount estimated at \$50,210.50, on account of the possible adverse result to claimant of claims pending and contemplated against it in reference to certain of the materials furnished claimant by Richfield appearing in the account between claimant and Richfield.

It is stipulated that the unpaid balance owing by Richfield to claimant is \$1,183,148.23. Of this amount the Special Master has, by his Report filed May 26, 1933, in the matter of the Bill in Intervention of this claimant,

recommended the allowance of \$403,993.92, as the aggregate of various items of money traced by claimant into specific properties, and the allowance and enforcement of a trust in such properties, respectively, for said items, respectively, in the aforesaid aggregate. The difference between said \$403,993.92 and said \$1,183,148.23 is \$779,154.31. No evidence is presented in regard to the claim for the estimated sum of \$50,210.50, and it is admitted by the claim, as filed, that it is purely contingent.

No reclamation, lien, or other preference is or can be claimed in reference to the net remainder of the unpaid balance here in question, for the reason that the fund containing the same was exhausted prior to receivership and no part of said fund came into the receiver's hands.

CONCLUSIONS

The claim should be allowed in the sum of \$779,154.31, without interest. The contingent claim should be disallowed and the aforesaid amount should be allowed as the remainder of the agreed unpaid balance after deducting the portion which is represented by allowance recommended by the Special Master as a charge against specific properties.

In case the amount of the allowance, aggregating \$403,993.92, recommended by the Special Master as a charge against specific properties, under claimant's aforesaid Bill in Intervention, shall be finally increased or reduced by the court, the amount now recommended for allowance on this claim should be reduced by the amount of such increase, or increased by the amount of such reduction. Further, in case, on the sale of any specific property for the satisfaction of the charge thereon, as finally adjudged

by the court, under claimant's aforesaid Bill in Intervention, a deficit in the amount of such charge shall remain, the amount of the allowance on this claim, as aforesaid, should be increased by the amount of the deficit so resulting in each instance.

Claimant will be entitled to allowance of such deficit as part of its general claim, for the following reasons. In the case of each of the properties involved under its Bill in Intervention, if any trust money was invested, so also was money of Richfield. The case differs from one in which the property was acquired with trust money only. In that instance, the beneficiary, having his election either to take the property as representing his money or to hold the trustee personally, would, if he took the property, take it as wholly representing the money, and hence wholly in satisfaction thereof; and thereafter he might keep or sell the property at his own will, reaping for himself such profit as might ensue from the use to which he might put it as his own, and correspondingly submitting to any loss that might so ensue. But in the present case the beneficiary is not in that position. He cannot take the property as wholly representing the trust money and hence wholly in satisfaction thereof, because there is other money in it, as well as his own; and he is therefore compelled to transform the property back into money, in order to make the restoration of his original money effectual. This necessity was created by the faithless trustee, who of course will not be allowed to derive any advantage from it. Depreciation must be attributed to the trustee, and not to the beneficiary, where the lapse of time is due to the necessity, forced on the beneficiary, of fighting for his rights. The latter is chargeable with the restored money only

when he gets it, and that occurs when a sale of the property yields it; and he is chargeable only in the amount which is restored to him, which is the amount the sale yields. The fundamental reason is, that where the trust money is mixed with other money in a specific property, there must be another transformation, i. e., back into money, otherwise he has nothing but a naked and unprofitable right, nothing more, in effect, than he had before; while, where the trust money is not mixed with other money in the property, there need be no further transformation, he takes the property and there is an end and satisfaction. The deficit remaining in the former case, after restoration of only a portion of the trust money through a process necessitated by the trustee's misfeasance, remains an obligation of the trustee.

It is true that there may never be any deficit, and that the amount, if any shall accrue, is not now ascertainable; and a like situation exists in reference to a possible modification of the allowance here by reason of a possible increase or reduction by the court of the amount recommended by the Master as a charge under claimant's aforesaid Bill in Intervention. The specific amount hereinbefore allowed, to-wit, \$779,154.31, should therefore stand as the allowance, unless and until proof shall hereafter be presented of facts for the application of the foregoing principles; and those principles should then be applied. Meanwhile, the receiver is entitled to rely and act on the specific allowance now made in the aforesaid specific amount, regardless of the possibility of modification.

Interest is disallowed for the reason that interest on an account starts only with demand, and there was no demand prior to receivership. The rule is discussed in detail in the Special Master's First Partial Report, on file.

page 239, re claim of Byron Jackson Co., Master's No. 537, Receiver's No. 727. California Usury Law (Stats. 1919, p. lxxxvii), repealing section 1917, Cal. Civil Code, and permitting interest only "after demand" on "the loan or forbearance of any money, goods or things in action or on accounts." *Burks v. Weast*, 67 Cal. App. 745, 752. *Willett v. Schmeiser Mfg. Co.*, 82 Cal. App. 249, 254. Even before the repeal of section 1917, Cal. Civil Code, which was the statute covering interest on implied contracts, including accounts, interest was not allowable without demand, in the absence of a settlement of the account and an ascertainment of the balance (*Heald v. Hendy*, 89 Cal. 632, 635). As the part of the account here involved is placed on the mere ground of creditor and debtor, the rule regarding interest on accounts should be applied.

It cannot be said that a demand was impossible. Richfield's control of claimant's bank account did not necessarily extend to claimant's board. From the beginning, September 30, 1929, to December 19, 1929, Richfield had only a minority representation on the board, and a demand could easily have been ordered. From December 19, 1929, to March 18, 1930, Richfield had five of nine directors, and after March 18, 1930, six. The attendance of the minority, with the absence of two of the majority, would have enabled the board to order a demand. Even on a full attendance, only one vote from the majority at a meeting before March 18, 1930, and two votes from the majority, at a meeting thereafter, would have enabled the board to order a demand. It cannot be conclusively presumed that the one or two votes from the majority would have been lacking. It is not inconceivable that one or two of the majority directors might have been faithful to their duty, if the question of demand had been presented to

the board; at any rate, we cannot say in advance that all of the directors who represented Richfield would have violated their duty. We are not justified in predicting any particular attendance at any meeting, nor are we justified in predicting any particular action at any meeting, from the mere fact that certain directors, even a majority, were representatives of the stockholder concerned.

This view is fortified, I think, by the fact that, under the decisions, interest is not allowable even on trust money traced into a fund. *First Nat. Bank v. Fidelity & Dep. Co.*, 48 Fed. (2d), 585, C. C. A. 9; *Poisson v. Williams*, 15 Fed. (2d) 582, D. C. E. D. N. Car.; *Smith Reduction Corp. v. Williams*, 15 Fed. (2d) 874, D. C. E. D. N. Car.; *Butler v. Western German Bank*, 159 Fed. 116, C. C. A. 5; *Hallett v. Fish*, 123 Fed. 201, C. C., D. Vermont; *Richardson v. Louisville Banking Co.*, 94 Fed. 442, C. C. A. 3; *Merchants' Nat. Bank v. School District*, 94 Fed. 705, C. C. A. 9; *Elizalde v. Elizalde*, 137 Cal. 634, 638. If interest is not allowable to a cestui, whose position would naturally be regarded as of greater appeal than that of a mere creditor, its allowance to a creditor should not be based on surmise. If claimant had traced all its money into the hands of the Richfield receiver, it could have recovered no interest; and its relegation to an inferior position on the principal, by its failure to trace, should not give it superior position on the interest; certainly not without something more than conjecture as to what a board might do.

Heard April 5, December 21, 1932."

II.

REPORT ON BILL IN INTERVENTION.

On May 26, 1933, said Special Master filed in the District Court of the United States for the Southern District of California, Central Division, his findings and conclusions on the bill in intervention filed by Universal Consolidated Oil Company set forth above, which are as follows:

“In the District Court of the United States
Southern District of California
Central Division

Security-First National Bank of)
Los Angeles, a national banking)
association, as trustee,)

Plaintiff,)

vs.)

Richfield Oil Company of Cali-)
fornia, a corporation, and William)
C. McDuffie, as Receiver of Rich-)
field Oil Company of California, a)
corporation,)

Defendants.)

Universal Consolidated Oil Com-)
pany, a California corporation,)

Intervenor.)

In Equity
Consolidated Cause
No. S-125-J

The Republic Supply Company of)
California, a corporation,)
)
Complainant,)
)
vs.)
)
Richfield Oil Company of Cali-)
fornia, a corporation,)
)
Defendant.)

Report of Special Master on Bill in Intervention of
 Universal Consolidated Oil Company

To the Honorable the District Court of the United States,
 in and for the Southern District of California, Central
 Division, and to the Honorable William P. James,
 Judge thereof:

WILLIAM A. BOWEN, Special Master appointed
 herein for the purpose of hearing and passing upon the
 bill in intervention of Universal Consolidated Oil Com-
 pany, a California corporation, respectfully reports as
 follows:

Pursuant to the order of reference, the hearing on said
 bill in intervention was consolidated with the hearing on
 the claim of said corporation, Master's No. 2637, Re-
 ceiver's No. 4622, filed against the receivership estate
 of Richfield Oil Company of California, and the report
 of the Special Master on said claim is submitted separately
 as a part of his report upon claims in said receivership
 estate, his findings therein being in consonance with the
 findings herewith reported on said bill in intervention.

The bill seeks, in effect, reclamation of various pieces of property by reason of the alleged tracing into each of said pieces of property of money of the intervenor alleged to have been misappropriated by Richfield Oil Company of California; and the reclamation is sought to be enforced by the declaration of a trust in each of said pieces of property in the amount of the money traced into the same and by the application of the proceeds of any sale herein of each of said pieces of property to the satisfaction of the intervenor's aforesaid interest. It is claimed that this interest, resting in prior and exclusive ownership, precedes any asserted interest on the part of Richfield Oil Company of California, its receiver, the holders of its bonds, and the trustee of its bond issue. Interest is claimed on the several amounts alleged to have been misappropriated and traced.

Two questions of mixed fact and law are presented:

First, whether the transaction between intervenor and Richfield Oil Company of California was a misappropriation by the latter or a bona fide loan to it; and second, if a misappropriation, whether and to what extent the moneys are traced into specific properties.

— 0 —

The allegations of paragraphs I, II, III, and VI of the bill in intervention are admitted by the pleadings, except that the final allegation of paragraph III, charging that the alleged property is held in trust for the intervenor and is subject to its prior right, is in dispute. The facts involved in the disputed allegations on both sides are found as follows.

FINDINGS OF FACT

-I-

ON THE QUESTION OF MISAPPROPRIATION
OR LOAN

The business of intervenor, hereinafter called Universal, was oil production; it had no refinery or pipe lines or marketing facilities. In 1925, again in 1928, and again in 1929, Richfield Oil Company of California, hereinafter called Richfield, investigated Universal's properties. At one time Richfield's production manager advised the chairman of the Richfield board that it would be well to acquire Universal's property in Lost Hills because of Richfield's properties in that section. No action was taken prior to the report of 1929. No additional property had been accumulated meanwhile by Universal. About the time of the 1929 investigation, which was completed in the latter part of July, 1929, Richfield's production manager and the chairman of its board discussed the possibility of development of the Lost Hills field. Later on there were conversations between the chairman of the Richfield board and one of its directors who was active in negotiating the purchase of stock in Universal, in which conversations it was stated that Universal was a fine producing company, that Richfield needed it as a complement to its own production, and that the cash position of Universal was a very nice cash position for a subsidiary company to have if it could be acquired by Richfield; and something was said about the fact that Richfield could advance some of that money to itself.

In August, 1929, there were outstanding of Universal's stock 358,103.8 shares of the par value of \$10.00 each, (the stock was originally of \$1.00 par value, making

3,581,038 shares, but all references herein are based on a par value of \$10.00).

By written agreements dated August 13, 1929, Joe Toplitzky, who was a director of Richfield, agreed to buy from William H. Crocker 167,000 shares of Universal stock, Crocker to deliver to Toplitzky forthwith the resignations of the president and the majority of the directors of Universal, effective at the will of Toplitzky; and the resignations of their successors to be deposited in escrow to be delivered to Crocker on default in payment of the purchase price, and the corporation, until payment of the purchase price in full, not to dispose of any of its assets or incur any liabilities, except in the usual course of business, nor to declare or to pay any dividends, but to maintain its present office and office and field personnel and to continue its present drilling and development program; and Richfield agreed to buy from Toplitzky up to 47,000 shares in the same ratio as the aggregate number of shares which might be taken down by Toplitzky out of the remaining 120,000 shares should bear to said 120,000 shares; and as to said 120,000 shares, the said Toplitzky, Herbert Fleishhacker and R. W. Hanna formed themselves into a syndicate, with Toplitzky as manager, for the purpose of taking down said 120,000 shares and selling or retaining the same, Toplitzky, as manager, to have exclusive power to determine when to sell the stock and in what amount, and Richfield to be paid 25% of all profits realized by the operation of the syndicate. By agreement dated January 28, 1930, Richfield agreed to buy from Toplitzky 106,000 shares.

On September 27, 1929, Richfield paid to Herbert Fleishhacker, by check, \$822,500.00, in payment for 47,000 shares of Universal stock. On January 29, 1930,

Richfield gave Toplitzky its check for \$221,202.08, and 70,666 shares of its stock, in payment for 106,000 shares of Universal stock. On March 5, 1930, Richfield gave Tucker Hunter-Dulin Company its check for \$10,625.00, and 3400 shares of its stock, in payment for 5,100 shares of Universal stock. The first mentioned 47,000 shares of Universal stock were not reissued in the name of Richfield until July 29, 1930, but on or about September 27, 1929, Richfield held endorsed certificates for the same, and was accordingly the unrecorded owner of 13.12% of the 358,103 shares outstanding. The aforesaid 106,000 shares were not reissued in the name of Richfield until later, as follows: 42,500 on February 13; 52,000 on February 14; and 11,500 on March 10, 1930; but on or about January 29, 1930, Richfield held endorsed certificates for the same, and was accordingly the unrecorded owner of 153,000 shares, or 42.73% of the outstanding stock. The aforesaid 5,100 shares (paid for on March 5, 1930) were reissued in the name of Richfield on March 7, 1930, and Richfield was accordingly on the latter date the owner of 158,100 shares, recorded and unrecorded, or 44.15% of the outstanding stock. Subsequently Richfield acquired additional stock, to the effect that on the following dates in 1930 it owned stock, recorded and unrecorded, in the following percentages of the whole issue: April 3, 44.52%; April 17, 44.52%; May 22, 51%; and on August 19, 52.16%, amounting to 186,778 shares, its ultimate holding. These shares have since been transferred to Security-First National Bank of Los Angeles, as trustee under the Richfield bond indenture.

The minutes of Universal show as follows:

September 30, 1929, directors' meeting: Talbot, who was chairman of the board of Richfield, was elected a director and president in place of Bishop, resigned. Fuller, who was president of Richfield, was elected a director in place of Crocker, resigned. Tucker, who was a director of Richfield, was elected a director in place of Harrison, resigned. Melvin, who was secretary, vice-president, and general counsel of Richfield, but not a member of the board, was elected a director in place of Long, resigned, and was also elected vice-president. Charlesworth, who was secretary to Melvin in the Richfield organization, and was an assistant secretary of Richfield, was elected assistant secretary. The articles were amended transferring the principal place of business from San Francisco to Los Angeles, and increasing the par value of the stock from \$1.00 to \$10.00. Any two of the following were authorized to sign checks on the Bank of America, on the Crocker First National Bank of San Francisco, and on the Anglo & London Paris National Bank: Melvin, vice-president; Long, secretary-treasurer; Charlesworth, assistant secretary; R. W. McKee (who was assistant to Talbot in the Richfield organization), and J. S. Wallace (who was a vice-president of Richfield but not a member of its board). The board of Universal was then composed of four members who were also connected with the Richfield organization and five members who remained in office from the old board. Long, who had been secretary-treasurer of Universal since 1922, remained as such until May, 1931, being then succeeded by Wallace.

December 19, 1929, directors' meeting: Dunlap, who was a vice-president and a director of Richfield, was elected a director in place of Phleger, resigned, and Noyes was

elected a director in place of Murphy, resigned. The board of Universal then consisted of five members who were also connected with the Richfield organization and four members who were not connected with that organization.

March 18, 1930, directors' meeting: McKee, who was assistant to Talbot in the Richfield organization, was elected a director in place of Noyes, resigned. The board of Universal then consisted of six members who were also connected with the Richfield organization and three members who were not.

April 4, 1930, directors' meeting: A dividend was declared in the sum of 50¢ per share of the par value of \$10.00, payable April 30, 1930, to stockholders of record April 15, 1930. Stearns or Coffey or Hudson or Mason or Long was each authorized to sign checks and drafts on the Los Angeles-First National Trust & Savings Bank, Los Angeles, to be valid when signed by any one of them. Wallace, McKee, Hess, and Long were authorized to sign checks on the payroll account with the Citizens National Trust & Savings Bank, Los Angeles, to be valid when signed by any two. A resolution was adopted approving an agreement dated February 26, 1930, between Richfield and Universal, signed by Wallace, vice-president, and Wilson, assistant secretary, for Richfield, and Stearns, vice-president, and Long, secretary, for Universal, in relation to the drilling and operating by Universal of property of Richfield in Santa Barbara county.

April 15, 1930, annual stockholders' meeting: Held at the principal place of business, 555 South Flower Street, Los Angeles. Present in person, 1080 shares; by proxy, in the names of Talbot, Fuller, Melvin, Stearns, and Dun-

lap, 257,414 shares; by proxy, in the name of Newberger, 1430 shares; by proxy, in the name of Montgomery, 100 shares; making a total of 260,024 shares out of a total of 358,103 shares outstanding. The acts of the board and officers as the same appear in the books and records of the corporation were in all respects ratified and approved as the acts and deeds of the corporation. The president, Talbot, presented his annual report, in writing, stating that copies would be mailed to all stockholders. Stearns made reports about the operations in the various fields. The following board was elected: Cameron, Farnsworth, Stearns, Dunlap, Fuller, Melvin, McKee, Talbot, and Tucker. The board then consisted of six members who were also connected with the Richfield organization and three members who were not.

April 15, 1930, directors' meeting: Present: Stearns, Farnsworth, McKee, Melvin, and Talbot. Talbot was elected president, Fuller vice-president, McKee, vice-president, Melvin, vice-president, Stearns, vice-president, Long, secretary-treasurer, and Charlesworth, assistant secretary.

June 30, 1930, directors' meeting: A resolution was adopted approving an agreement dated May 1, 1930, between Richfield and Universal, executed by Wallace, vice-president, and Wilson, assistant secretary, for Richfield, and Stearns, vice-president, and Long, secretary, for Universal, relating to the drilling of the property of Richfield in the Inglewood District, Los Angeles county. A resolution was adopted ratifying agreements dated May 9, 1930,

with Richfield for the sale of gas and casing head gasoline produced from certain properties in the Inglewood district, the same being signed by Stearns, vice-president, and Long, secretary, for Universal. Cameron resigned as a director.

September 23, 1930, directors' meeting: A resolution was adopted ratifying an agreement dated September 18, 1930, with Signal Hill Gasoline Company (which was a subsidiary of Richfield) for the sale of natural gas from property in the Kettleman Hills field, the same being signed by Stearns and Long for Universal.

Prior to the meeting of September 30, 1929, the business office of Universal was in San Francisco. Following that meeting it was removed to Los Angeles. McKee advised Long, who was and had been secretary and treasurer of Universal, that he was privileged to come to the Los Angeles office, which he did. Stearns, one of the original Universal directors, was the original field manager of Universal and remained in that capacity after Richfield acquired the Universal stock.

0

Between January 15, 1929, and September 14, 1929, Universal loaned in New York on call various amounts aggregating \$1,500,000.00, and this aggregate sum was outstanding on call loans on the latter date. These loans were afterwards called in full, and the proceeds were deposited in Universal's bank account as follows: \$1,100,000.00 during October, 1929, \$200,000.00 in Novem-

ber, 1929, and \$200,000.00 on January 20, 1930, making in all \$1,500,000.00.

In February, 1929, Universal loaned to Provident Loan Association \$200,000.00 on its note, and this note was paid in full in October, 1929, and the proceeds were deposited in Universal's bank account.

Universal carried a ledger account of "call loans", which account shows loans made in New York as above stated, and shows the withdrawals and deposits aggregating \$1,500,000.00, as aforesaid. The Provident Loan note for \$200,000.00 was set up on Universal's books in a note receivable account.

After the initial acquisition of Universal stock by Richfield, so much of the aforesaid moneys as was in the Crocker First National Bank was transferred to the account of Universal in the Bank of America or in the Anglo & London Paris National Bank. The withdrawal of the aforesaid call loan money from the New York market was ordered by Talbot and the depositaries thereof were selected by him. The money was recalled from New York by McKee under instructions from Talbot, and McKee directed Long, who was secretary of Universal, to effect the withdrawal. Long accordingly instructed the Crocker First National Bank of San Francisco, which bank had originally transmitted the money to New York, to effect the recall thereof, and the bank did so. Zanzot, who had been in charge of the book accounts of Universal since 1923, made the entries on the books in reference to the recall of the money from New York.

Checks were drawn on the Universal bank accounts in favor of Richfield as follows:

<u>Date</u>	<u>Amount</u>	<u>Signatures</u>	<u>Drawee Bank</u>
Nov. 13, 1929	\$350,000.00	Long and McKee	Bank of America of California (Los Angeles)
Nov. 13, 1929	400,000.00	Long and McKee	Anglo & London Paris National Bank of San Francisco
Jan. 20, 1930	200,000.00	Long and McKee	Bank of America of California
Feb. 15, 1930	250,000.00	Long and McKee	Bank of America of California
Feb. 15, 1930	250,000.00	Long and McKee	Anglo & London Paris National Bank of San Francisco
Feb. 25, 1930	100,000.00	Long and Charlesworth	Bank of America of California
Feb. 27, 1930	100,000.00	Long and McKee	Bank of America of California
June 6, 1930	75,000.00	Long and Charlesworth	Bank of America of California

All of the aforesaid checks were deposited by Richfield in its general bank account in Security-First National Bank of Los Angeles.

On February 17, 1930, Richfield, by check on Security-First National Bank of Los Angeles, repaid to Universal \$100,000.00 of the moneys represented by checks of Universal made prior to that date as aforesaid, and said check of Universal for \$100,000.00 was deposited in the Bank of America of California at Los Angeles to the credit of Universal. No other payment has been made by Richfield to Universal on account of the moneys rep-

resented by the aforesaid checks of Universal. The net aggregate of said checks, after allowing credit for said \$100,000.00, is \$1,625,000.00. On April 15, 1930, Richfield gave its check to Universal for \$600,000.00 on account of the aforesaid moneys, but later, on the same day, Universal gave its check to Richfield in the same amount, thus leaving the account unchanged.

No note was ever given by Richfield to Universal for any of the moneys represented by the aforesaid checks of Universal, nor was any security given in connection therewith. No resolution was ever adopted by the Board of Directors of Universal authorizing or ratifying the issuance of said checks to Richfield, nor is there any resolution in the minutes of Universal from September 30, 1929, to the time of the appointment of the Richfield receiver, January 15, 1931, authorizing any loans to Richfield, or authorizing any officer of Universal or any one else to loan any of the Universal money to anybody. Just before the first meeting of the Universal board, after the first passage of said money to Richfield, Long, secretary of Universal, stated to McKee the program that should be taken up at the meeting and among other things that the transfer of said money to Richfield, which he designated as a loan, should be ratified by the board; to which McKee replied that Talbot would handle it. The matter was not brought up at the meeting. Long was not called in at any of the directors' meetings of Universal for the purpose of giving advice with respect to the accounts.

Talbot determined the time and amounts which passed from Universal to Richfield and gave directions to McKee to cause the moneys to be transferred from Universal to Richfield. McKee passed these instructions along to

Long, who was secretary and treasurer of Universal, and had been secretary and treasurer thereof since 1922. Long directed Zanzot, who was in charge of the Universal books and had been in charge thereof since 1923, to prepare the checks and make the entries and how the entries should be made on Universal's books. Zanzot drew the checks and made the entries on Universal's books.

At the time of the passage of the money from Universal to Richfield, Lyons was in charge of the Richfield books acting under McKee's supervision, and McKee knew that entries were made at the time on the Richfield books, and that like entries were made on the Universal books. McKee gave direction for the entry in the Universal books by way of a charge against Richfield on open account.

Long testifies that at the time when he suggested to McKee that the first transfer of money be ratified by the Universal board, he regarded it as a loan. Zanzot testifies that when Long and himself spoke of this account between themselves, he always understood it to be a demand account, that the money was payable back to Universal on demand, that he recalls no discussion of it as anything other than a loan demand account at the time, and that he never understood that it was anything other than that in his accounting work.

In transferring the money to Richfield, the practice was to draw a voucher check, enter the check in the voucher record, and post that to the ledger account. The caption of the account with Richfield in the Universal ledger was "Accounts receivable—Richfield Oil Company of California." This account reflects all of the money in question, but it does not reflect all of the charges to Richfield.

There was also a field ledger account, which took care of materials and the like sold to Richfield. A ledger account headed "Richfield Oil Company of California—Current Account" starts with December 31, 1929, and brings forward the balance of charges from the ledger account entitled "Accounts receivable—Richfield Oil Company of California" on December 31, 1929.

The Universal ledger account entitled "Accounts receivable—Richfield Oil Company of California" charges to Richfield three items amounting to \$775,000.00 on November 12 and 13, 1929, (which comprises the two checks of November 13th aggregating \$750,000.00, plus a check of November 12th for \$25,000.00, which latter check is not involved here), and charges interest on November 30, 1929, amounting to \$1879.16. The entries credit on January 3, 1930, \$1879.16 (representing payment of said interest), and on February 17, 1930, \$100,000.00 (representing payment in that amount on principal as above mentioned). The entries charge on January 20, 1930, \$200,000.00, on February 15, 1930, \$500,000.00, on February 25, 1930, \$100,000.00, and on February 27, 1930, \$100,000.00, (representing moneys transferred from Universal to Richfield, as aforesaid). The entries charge interest as follows: January 31, 1930, \$3278.13; February 28, 1930, \$3907.65; March 31, 1930, \$5425.00.

In the Universal ledger account "Richfield Oil Company of California—Current Account", which starts with December 31, 1929, and brings forward the balance of charges from the account last above mentioned, the entries of the last day of each month charge the following: January 31, 1930, check register \$200,000.00 (which is the money which passed on January 20, 1930); February 28, 1930, check register \$700,000.00 (which represents the

money which passed on January 20, February 15, and February 25); and April 30, 1930, check register cash advance \$600,000.00 (which represents a check of April 15, given by Universal to Richfield in exchange for Richfield's check of that amount on that day).

Richfield kept a ledger account with Universal headed "Universal Consolidated Oil Company—Current Account." This account shows charges, credits, and balances on the last day of each month. On November 30, 1929, it shows a balance in favor of Universal in the sum of \$741,471.23. On January 31, 1930, it shows a balance in favor of Universal in the sum of \$942,531.33. On February 28, 1930, it shows a balance in favor of Universal in the sum of \$1,566,626.46. On June 30, 1930, it shows a balance in favor of Universal in the sum of \$1,598,434.97. On January 14, 1931, the day before the appointment of the Richfield receiver, it shows a balance in favor of Universal in the sum of \$1,248,937.82. The credits to Universal in this account include the sums which passed as aforesaid from Universal to Richfield.

The following appear with reference to interest:

December 1, 1929, invoice of Universal to Richfield interest on \$750,000.00 at 5 1/8% per annum, November 13 to 30, 1929, \$1815.10. OK G.P.L. (This is G. P. Lyons, who was in charge of the Richfield books).

December 1, 1929, invoice of Universal to Richfield for interest on \$25,000.00 at 5 1/8% per annum, November 12 to 30, 1929, \$64.06. OK G.M. (This item of \$25,000.00 is not one of the items directly in question here).

December 31, 1929, invoice of Universal to Richfield interest on \$750,000.00 at $4\frac{3}{8}\%$ per annum, November 30 to December 31, 1929, \$2825.52. OK C.T. Hancock.

December 31, 1929, invoice of Universal to Richfield interest on \$25,000.00 at $4\frac{3}{8}\%$ per annum, November 30 to December 31, 1929, \$94.18. OK C.T. Hancock. (This item of \$25,000.00 is not one of the items directly in question here).

January 2, 1930, check from Richfield to Universal for \$1879.16 on First National office of Security-First National Bank of Los Angeles.

January 2, 1930, voucher of Richfield for the aforesaid check audited by B. C. with memo as follows: 12/1 interest on \$750,000.00 November 13 to 30, 1929, \$1815.10; 12/1 interest on \$25,000.00 November 12 to 30, 1929, \$64.06; total \$1879.16.

January 31, 1930, invoice of Universal to Richfield interest on \$750,000.00 at $4\frac{1}{2}\%$ per annum December 31, 1929, to January 31, 1930, \$2906.25. OK Hancock.

January 31, 1930, invoice of Universal to Richfield interest on \$25,000.00 at $4\frac{1}{2}\%$ per annum, December 31, 1929, to January 31, 1930, \$96.88. OK Hancock. (This item of \$25,000.00 is not one of the items directly in question here).

January 31, 1930, invoice of Universal to Richfield interest on \$200,000.00 at $4\frac{1}{2}\%$ per annum, from January 20, 1930, to January 31, 1930, \$275.00. OK Hancock.

March 1, 1930, invoice of Universal to Richfield, ok'd by Hancock, for interest at $4\frac{1}{2}\%$ per annum as follows:

\$750,000.00	Jan. 31 to Feb. 28	\$2479.17
200,000.00	Jan. 31 to Feb. 28	661.11
500,000.00	Feb. 15 to Feb. 28	767.36
100,000.00	Feb. 25 to Feb. 28	35.42
100,000.00	Feb. 27 to Feb. 28	11.81
		<hr/>
	Total	\$3954.87
Less interest on \$100,000.00	Feb. 17	
to Feb. 28		129.86
		<hr/>
	Balance	\$3825.01

March 1, 1930, invoice of Universal to Richfield interest on \$25,000.00 at $4\frac{1}{4}\%$ per annum, from January 31 to February 28, 1930, \$82.64. OK Hancock. (This item of \$25,000.00 is not one of the items directly in question here).

March 31, 1930, invoice of Universal to Richfield interest on \$1,575,000.00 at $4\frac{1}{4}\%$ per annum, February 28 to March 31, 1930, \$5425.00; with query signed J.A.T. as follows: "Mr. Santler is it ok?"

March 31, 1930, invoice of Universal to Richfield for interest on advances \$1,575,000.00 from February 28, 1930, to March 31, 1930, at 4% per annum, \$5425.00. OK J.A.T. (J. A. Thompson of the Richfield organization).

April 30, 1930, invoice of Universal to Richfield interest on \$1,575,000.00 at 4% per annum from March 31, 1930, to April 30, 1930, \$5250.00. Mr. Perrin.

Universal's ledger sheet headed "Accounts Receivable Richfield Oil Company of California" charges interest on

November 30, 1929, amounting to \$1879.16 on three items of November 12 and 13, 1929, aggregating \$775,000.00, and credits on January 3, 1930, \$1879.16, and charges further interest as follows: January 31, 1930, \$3278.13; February 28, 1930, \$3907.65, and March 31, 1930, \$5425.00.

Universal's ledger account "Richfield Oil Company of California—Current Account" shows interest charges on the last day of each month in 1930, commencing January 31 and ending December 31.

The charging of interest against Richfield on the transactions involved here was dictated to Long, Universal's secretary and treasurer, by McKee and Long gave instructions accordingly to Zanzot, Universal's bookkeeper. Long told Zanzot to use the average New York call rate and to bill Richfield accordingly. That interest rate was computed at certain intervals on this account on the Universal books and statements to that effect were rendered to Richfield. The only check for interest on the transaction involved here was the check given by Richfield on January 2, 1930, for \$1879.16, which paid interest as charged on the Universal books to November 30, 1929, on the two items of November 13, 1929, aggregating \$750,000.00, and on an item of \$25,000.00 on November 12, 1929. Universal's counsel stated at the hearing: "We will concede that under the instructions of Mr. McKee they asked for interest."

The accounts between Universal and Richfield show numerous financial and commercial transactions from November, 1929, to the date of the appointment of the Richfield receiver, January 15, 1931, in addition to the transactions here in question. The Universal ledger account

headed "Accounts Receivable Richfield Oil Company of California" from November 12, 1929, to December 31, 1929, and its account headed "Richfield Oil Company of California—Current Account" transferring the balance in the first named account on December 31, 1929, and running to and beyond the date of the appointment of the Richfield receiver, contain numerous charges against Richfield apart from the charges of principal and interest here particularly in question, for cash, interest, revenue stamps, oil, gas, gasoline, invoices, labor, power, and the like, and numerous credits to Richfield apart from the item of interest and the items of \$100,000.00 and \$600,000.00 on principal in the transaction here in question, for cash, compensation insurance, other insurance, sundry debit advices, and other items posted from the journal. The total charges in these accounts amount on January 14, 1931, to over two and three quarter million, and the total credits on that date amount to over a million and a quarter. In addition to the money in question here, Richfield is charged with cash on November 12, 1929, \$25,000.00, on June 10, 1930, \$28,000.00, on June 17, 1930, \$5,000.00, on August 14, 1930, \$95,000.00. In addition to the \$100,000.00 paid on February 17, 1930, on the account here in question, and the \$600,000.00 exchange on April 15, 1930, Richfield is credited commencing about July 15, 1930, and ending about October 11, 1930, with cash repaid by it as follows: July 15th, \$50,000.00; July 18th, \$25,000.00; July 18th, \$37,000.00; July 24th, \$20,000.00; August 19th, \$40,000.00; August 25th, \$20,000.00; September 3rd, \$15,000.00; September 10th, \$20,000.00; September 11th, \$5,000.00; September 18th, \$15,000.00; September 27th, \$20,000.00; October 2nd, \$15,000.00; October 11th, \$5,000.00. On January 10, 1931, Richfield is

credited with an additional payment of \$11,000.00. While Richfield was paying back the aforesaid items from July 15, 1930, to October 11, 1930, amounting to the sum of \$287,000.00, it was receiving from Universal the sum of \$128,000.00. It is agreed on both sides that after allowing Richfield all the credits to which it is entitled and charging it with all proper charges, including the moneys which passed from Universal to Richfield here in question, an unpaid balance remains on Richfield's part in favor of Universal on the whole account in the sum of \$1,183,148.23, exclusive of interest.

— 0 —

An annual meeting of Universal's stockholders was held on April 15, 1930, at 2 o'clock P. M. at 555 South Flower Street, Los Angeles. On the morning of that day, before the meeting, a Richfield check to the order of Universal for \$600,000.00 was signed by Wallace and Long on the First National office of the Security-First National Bank of Los Angeles. A request for this check was signed on said date by Perrin, disbursement auditor of Richfield, and approved by Thompson of the Richfield organization, addressed to Gallagher "To have check drawn in favor of Universal for \$600,000.00 and delivered to L. E. Long RUSH." On the same day a voucher was approved by Perrin "Richfield to Universal 4/15 debit \$600,000.00, balance \$600,000.00, account 386."

On said morning, Long handed said check to Zanzot, the bookkeeper of Universal, and asked the latter to deposit it. The check was accordingly deposited in the Bank of America of California, at Los Angeles.

In the afternoon of the same day, Long instructed Zanzot to draw a Universal check for \$600,000.00 in favor of

Richfield. He did so and gave it to Long to have it signed and delivered to Richfield. This check was signed by Long and McKee and deposited in the Richfield bank account.

On the morning of April 15, 1930, before Universal received the last mentioned check for \$600,000.00 from Richfield, the balance of cash on hand in Universal was \$372,977.14.

The report dated April 8, 1930, signed by James A. Talbot, President, which was presented to the meeting of the stockholders of Universal on April 15, 1930, states that "During the year Richfield Oil Company of California acquired 51% of the outstanding stock of this corporation on account of the company's future production potentialities", and contains a balance sheet as at December 31, 1929, of Universal Consolidated Oil Company and its subsidiary (Lost Hills Water Company, wholly owned) and consolidated profit and loss account for the year ended December 31, 1929, of said company and its subsidiary, and consolidated surplus accounts of said company and its subsidiary, with a certificate of Peat Marwick, Mitchell & Co., Accountants and Auditors, dated April 1, 1930. The balance sheet shows among the assets Demand Loans in the sum of \$769,539.72, Cash in banks and on hand \$989,077.67, and Call Loans in the sum of \$200,000.00.

The last previous report of Universal dated October 8, 1929, and signed by James A. Talbot, President, being for the nine month period ended September 30, 1929, states: "The company is in a very strong financial position, with current assets of \$2,100,000.00, \$1,400,000.00 of which is in cash. The ratio of current assets to cur-

rent liabilities is approximately eight to one. Control of the company has recently passed to Richfield Oil Company of California and a group of substantial San Francisco and Los Angeles investors. Management of the company's affairs is in the hands of the executive officers of Richfield Oil Company of California, the field operations being continued under the capable management of Mr. Edward Stearns, who has been in charge of field operations of this company for many years." The only financial statement with this report is an uncertified profit and loss account for said nine months.

0

Fuller, Dunlap, Talbot, Melvin, and McKee were familiar at the time with the fact that Richfield was using money from Universal; it was discussed in a general way from time to time by the officers of Richfield. The Universal directors' meetings were perfunctory and the matter was not discussed at such meetings. McKee knows of no instance of any information being given to any of the directors of Universal who were not Richfield's nominees, or to any of the stockholders of Universal, that Richfield had any of Universal's money.

Stearns, who was production manager of Universal since 1913 and a director, first learned about the transactions in question here about the time of a meeting of the Universal board on September 23, 1930, which was called for the purpose of declaring a dividend. Long told Stearns at that time that they had no money with which to pay the dividend, and on Stearns' asking where the money was, Long said that Richfield had drawn it out and put it in its account. After getting this information from Long, Stearns spoke to Melvin about it and also

to Farnsworth, who was a director of Universal, but not of Richfield, and it was proposed to consult an attorney in order to ascertain whether a director who did not know about the transaction would be responsible. This matter was dropped without any action. Stearns was present at the Universal stockholders' meeting of April 15, 1930, and saw the annual report hereinbefore referred to. He does not know whether he noticed the item of "Demand Loans \$769,539.72." He did not ask any one as to whom that money had been loaned. He does not recall any discussion at all on that subject at the stockholders' meeting.

Long at one time received a letter from a stockholder named L. H. Van Wyck, inquiring as to what had become of the large amount of cash held by Universal. Long did not give him the information. Long does not recall any letters from any other stockholders to that effect.

About the middle of January, 1930, R. L. Bryner, representing a stockholder of Universal, applied to McKee, who sent him to Long, and Bryner gave Long a list of things he wanted to know. Long shortly after gave him a statement answering all of the questions as to production and the like and a statement of the financial condition of Universal as of that approximate date. This statement showed accounts receivable \$21,000.00, notes \$3,250.00, cash on hand \$986,035.00, and "call—1 day notice \$1,025,000.00." Bryner asked Long if the last mentioned \$1,025,000.00 was in the call money market and Long said "No." Bryner asked him where the money was and Long said the information would have to be obtained from McKee. Bryner applied to McKee, who put him off, and subsequently Bryner gave Melvin a letter demanding to see the books of Universal. Melvin said he saw no reason why Bryner could not see the books and asked what

Bryner wanted to know chiefly, to which Bryner replied that he wanted to know where this million and odd dollars was. Melvin said that he would take the matter up with McKee and Talbot. In about a week Melvin told Bryner that McKee had instructed him not to let Bryner see the books, and that as there were only fifty shares standing in Bryner's name, they did not deem that sufficient to warrant his seeing the books of the company. Bryner did not see the books and was not informed as to who had the million dollars. He did not ascertain that until after the receivership of Richfield. Bryner, at the time of his interview with Melvin, had only fifty shares standing in his name, but he had 1700 shares besides with a broker. He wanted to know whether he should increase his holdings as he was trading in that stock all the time. He did not have any stock in his name at the time of his first application to McKee and Long. He acquired the 50 shares in the early part of February, 1930, between his first application and his interview with Melvin. He acquired those 50 shares solely for the purpose of going into the company and saying he was a stockholder of record.

0

The following are the facts in reference to the practice of Universal in making loans, prior to September, 1929. The Crocker First National Bank of San Francisco transmitted the money to New York. Long sometimes instructed the Bank to transmit the funds and Ray Bishop, President of Universal, sometimes instructed the Bank. Long instructed the Bank under directions received by him. He was thoroughly familiar with all of the facts with regard to all loans which Universal ever made while

he was treasurer. They were all made by Bishop, the President, who also acted as general manager of Universal until his resignation, and they were recorded on the books as call loans, crediting cash and charging the call loan account. There was never any resolution by the board of Universal authorizing any of the previous loans made by Bishop or by Long. The practice was that Bishop or Long took action and reported later to the board. No one but Bishop and Long was active in the actual management outside of the field work. Stearns was superintendent in the field.

Stearns does not know what was done about loans during the two years before 1930. He knows that money was loaned in New York, but he did not know any of the particulars or anything about it. He does not know what the practice of Universal was with regard to whether or not it made resolutions in connection with the making of company loans because he never had much connection with the business end of it. He was engaged principally in looking after the operations in the field. The only case he knows of in regard to loaning money was the loaning of money in New York, but he does not know about that directly but only by hearsay. He does not know the amount involved nor whether any resolutions were passed by the board concerning those loans; no resolutions thereon were made at any meeting attended by him. There were a good many meetings which he did not attend. He was in the field most of the time. No resolutions concerning any loan to anybody were made at any meeting which he attended.

Regarding the practice in making loans after September, 1929, there was only one loan apart from the money that went over to Richfield. This loan was made to one Bachman for \$50,000.00 on instructions from McKee. The loan was entered in the books and a note was taken. There was no resolution of the board authorizing or approving the loan. The Bachman loan was made before Richfield acquired all of its stock.

0

After the call loans were withdrawn and the money passed to Richfield, Universal was not in any activity that required the use of that amount of money. It was surplus cash that would have to be invested. It is true that Universal had requirements for cash in its operations up to the date of the Richfield receivership inasmuch as it was drilling wells and had an operating payroll, but it had sufficient funds for that purpose, except that at one time it was unable to meet its payroll or discount its bills and Long made demand on Richfield for funds and received a portion of what he asked for. Universal's operations were not interfered with, however, for lack of cash to meet payrolls and operating expenses.

Dividends were regularly declared by Universal. The quarterly dividend declared on September 30, 1929, was paid out of its own funds, but the next quarterly dividend amounting to \$178,000.00 at 50¢ per share was paid by calling on Richfield to repay Universal some of the money and by crediting Richfield's account on the books for the

amount of its dividend. At the meeting on September 23, 1930, which was called for the purpose of considering the declaration of a dividend, the chairman recommended that no dividend be declared, and no action thereupon was taken for the reason that the company's funds on hand were insufficient for the payment of a dividend.

— 0 —

Richfield was at various times able to borrow money from local banks to the extent of millions of dollars without security. The maximum of Richfield's bank loans at the time in question was about \$10,300,000.00 and Richfield's highest loan with Security-First National Bank of Los Angeles was about \$2,250,000.00, all unsecured. It does not appear whether or to what extent the loans in these amounts originated during the period in question here.

At the opening of the bank on November 13, 1929, Richfield had a deposit balance with Security-First National Bank of Los Angeles in the sum of \$1,157,755.05. From November 13, 1929, to January 14, 1931, Richfield deposited in said bank account from sources other than Universal the sum of \$81,903,908.39. Its deposits in said bank account during said period of moneys received from Universal aggregated \$2,448,000.00.

The foregoing constitutes all of the evidence regarding Richfield's financial condition at the time of the transactions with Universal in question here.

-II-

THE TRACING OF THE MONEY

The moneys in question here were deposited by Richfield, as received from Universal, in Richfield's general bank account with Security-First National Bank of Los Angeles. At the time of the first deposit, the account contained a large balance, and it continued thereafter to receive daily deposits, in large sums, of Richfield's general funds. On January 8, 1931, a week before the appointment of the Richfield receiver, the account was wholly depleted, and at the close of that day and the opening of January 9th there was an overdraft of \$18,080.18. The moneys here in question were mingled in said account with the general funds of Richfield, and with other moneys received from Universal.

From time to time, during the period in question, Richfield paid in whole or in part, by check on said bank account, for various properties, and it is sought to trace the moneys here involved through said bank account into said properties. A list of the properties follows at the end of these Findings of Fact, and they are referred to meanwhile by the parcel numbers given in said list. No issue is tendered, and no finding is made, on the title to any of the properties, the claim being confined to such right, title, and interest, if any, as Richfield and its receiver may have.

No attempt is made to trace the money into the hands of the receiver, for the reason that the bank account which contained it was wholly depleted a week before the appointment of the receiver, and it is not contended that subsequent repletion of the account would operate to restore the trust funds. The effort is therefore to trace the money into property acquired therewith.

The theory of the attempted tracing is as follows:

The bank balance out of which payment is made for a specified property is presumed to contain the trust money, in whole or in part. This is due to the presumption that Richfield has previously disbursed from the account its own money rather than the trust money, whence it follows that the instant balance must contain trust money, if the account has not meanwhile been wholly depleted, as it has not in the present instance. Whether the whole of the trust fund, or only a part, remains in the immediate balance, depends upon the intermediate state of the account. If during the interim the balance falls at any time below the amount of the trust money previously deposited, it is presumed that Richfield has at that time spent not only all of its own funds in the account, but a portion of the trust fund, and that the portion of the account then remaining is trust money, though less than the amount of trust money previously deposited; and, inasmuch as subsequent repletions of the account are not to be deemed a restoration of the trust fund, the portion of the trust fund represented by the lowest balance existing in the aforesaid interim is deemed the portion of the trust fund which remains in the bank balance out of which payment is made for the specified property. If the aforesaid lowest balance is not less than the amount of the previously deposited trust fund, then the whole of the trust fund is deemed to be contained in the bank balance out of which payment is made for the specified property.

Having thus the whole or a part of the trust money on hand in the bank balance out of which payment is made for the specified property, the payment will consume either the whole or a part of such bank balance. If the whole, then the payment necessarily includes the trust money

which forms part of the bank balance, and the trust money is thus traced into the specified property. If the payment consumes only a part of the bank balance, it is still to be presumed that the trust money is included in the payment, rather than in the unexpended balance, for the following reason. The unexpended balance being afterward wholly depleted, as shown by the overdraft on January 8, 1931, and being accordingly untraceable, it is presumed that the money, including this unexpended balance, which Richfield afterward untraceably spent, was its own money, whence it follows that the money which went into the specified property was trust money, thereby in effect preserved and retained, though in another form; and on the other hand, the presumption that Richfield, in disbursing its bank balance, spent its own money rather than the trust money, does not apply to the money invested in the specified property, because in effect it was not spent at all, in the sense of an untraceable dissipation, but was merely converted into another form, readily identifiable, and so continued to be held; because the cestui que trust is entitled to treat as his own that part of the common fund which is preserved, whether in the form of identified property, as here, or in the form of an undisposed money balance; and because the presumption first referred to is for the protection of the cestui que trust, and should not be applied in such manner as to defeat his rights.

The method involved is as follows:

(a) On the first deposit of so-called trust money, ascertain the lowest bank balance in the period from said first deposit to the first payment thereafter on property from the common account. Enforce a trust on the property for the payment, but limited to the amount of said

low bank balance, or to the amount of said first deposit, whichever is less.

(b) Ascertain the lowest bank balance in the period from the aforesaid first payment to the next payment on property, whether the same property as in (a) or otherwise; no second deposit of trust money having been made meanwhile. Enforce a trust on the last mentioned property for the payment, but limited to whichever of the two following amounts is less: (1) the low balance mentioned in this paragraph; or, (2) the remainder, if any, of the low balance in (a) or of the first deposit of trust money, whichever is less, after applying the same on the first payment in (a).

(c) Proceed as in (b) on each succeeding payment on property, to and including the payment next before the second deposit of trust money.

(d) On the second deposit of trust money, ascertain the lowest bank balance in the period from said second deposit to the next payment on property, whether the same property as any previous item or otherwise. Enforce a trust on the last mentioned property for the payment, but limited to whichever of the two following amounts is less: (1) the low balance mentioned in this paragraph; or, (2) the second deposit plus any remainder of the first deposit after application on payments made before the second deposit, as in (b) and (c).

(e) Ascertain the lowest bank balance in the period from the payment in (d) to the next payment on property, whether the same property as any previous item or otherwise; no third deposit of trust money having been made meanwhile. Enforce a trust on the last mentioned property for the payment, but limited to whichever of the two

following amounts is less: (1) the low balance mentioned in this paragraph; or, (2) the remainder, if any, of the low balance in (d) or of the second deposit of trust money plus any remainder of the first deposit, whichever is less, after applying the same on the payment in (d).

(f) Proceed as in (e) on each succeeding payment on property, to and including the payment next before the third deposit of trust money; and thereafter in like manner to the last payment following the last deposit of trust money.

It is necessary to determine the proper method of ascertaining low balances. There are three alternatives. A low balance on any day may be looked at as either:

1. The closing balance, after crediting on the books the opening balance and all deposits for the day, and charging on the books all withdrawals for the day; thus disregarding the actual order of deposits and withdrawals in point of time, and consequently disregarding the possibility that, by observing such order, a lower balance may have resulted during the day.

2. The balance shown during the day as a result of periodical postings of deposits and withdrawals, after crediting the opening balance; thus either regarding or disregarding the order of deposits and withdrawals in point of time, and consequently either observing or neglecting the true balances, according to the practice of the bank in posting.

3. The balance shown by deducting all withdrawals posted during the day from the opening balance, without crediting deposits for the day; thus disregarding the actual order of deposits and withdrawals in point of time, and

assuming an order which would produce the least possible balances during the day.

The facts bearing on this subject are as follows:

At 8:15 and at 11:15 in the morning the aforesaid bank receives the checks from the clearing house, these being known as the first and second clearings. The checks are proven in and sorted to the various bookkeepers. There is no certain time set for a bookkeeper to post these items or to sort them; it is left to his judgment. Sometimes beginning as early as 10:30 in the morning and sometimes not until 2:30 checks that are received over the window are given to the bookkeepers for posting. A check may come in at 8:15 in the clearings and be given to the bookkeeper and it may stay on his desk and may not be posted to the account until after a deposit that is made at 2:30 in the afternoon. Checks coming in at 11:15 may be posted before checks that came in at 8:15, because the bank does not have to return refused checks to the clearing house until 2:30 and therefore the bookkeeper has from the time he begins work in the morning until 2:30 to ascertain whether or not the check will be honored. Under this system, it would be possible for an opening balance to show \$100,000.00 and the closing balance to show \$100,000.00, and yet in the meantime checks might have been entered on the account which would completely wipe out the balance at noon and then other deposits in the afternoon might be made which would bring it up to a closing balance of \$100,000.00. There is no way under the system used by said bank of telling whether that actually happened on a particular day or not.

Posting is made by said bank on machine books and on such books the total must be pulled before the sheet can be taken out of the machine. The bookkeeper is

continually posting during the day; when he posts in a particular account he takes a balance at that time. Sometimes there will be three balances shown in the course of a day, sometimes seven or eight, according to how many times the bookkeeper goes through his ledger. The bookkeeper could be engaged in making his posting and casting up this balance and at the same time in another part of the bank somebody could be depositing checks in that account or somebody could be withdrawing funds from that account. Also, the bookkeeper may have other checks on his desk which are not included in the group posted at the time. The balance he strikes does not necessarily represent the actual balance of all deposits and checks at the time. It represents only the balance of those checks and deposits which are then posted. The balance taken periodically during the day, as aforesaid, does not necessarily give a true picture of the low balance for the day, because it ignores the unposted checks.

The bookkeeper uses his discretion as to which checks coming in at the same time will be sent back as overdrawing the account. Checks coming in through the clearing house have to be posted and paid or refused by 2:30. If another check comes in after 2:30 that would be returned. If they both come in at 8:15 from the clearing house, there is no certain rule. There will be a period when the bookkeeper has not posted some checks and a check comes in over the counter in the meantime, in which case the bank will honor the check that comes in over the counter rather than the checks that have not been posted. The result is that in determining the balance at any time for honoring other checks that may come in, the bank uses the time of the actual posting and not the time of the receipt of the check. The bookkeeper may have on

the other side of the desk some checks and deposits for Richfield and he may ignore those and post those in front of him, although the former may have come in first. If a deposit of \$10,000.00 in cash comes in at 10:00 over the counter, it may not be actually posted to the account by the bookkeeper until 12:00 or 2:00 or 3:00 o'clock. The chances are that it would not be posted until after 3:00 o'clock. On the other hand, if some one comes in with a check and cashes it for \$10,000.00, that might not be entered and charged until the afternoon against the particular account. In other words, it is purely arbitrary. The intermediate balances are merely working balances, so that the bookkeepers can go ahead with their work. The only balance that the bank will recognize as really showing the state of the account is the one at the close of the day. When the bank is asked by a depositor to certify his check, the teller takes the ledger sheet of the account to see whether there is sufficient money and if sufficient money does not appear on the ledger he examines the deposits before he certifies the check. If there is sufficient money, he enters that in pencil on the ledger sheet including the deposits which have not been posted. That is not done in every case, but only for certification, and also when a check comes in to be cashed. In these respects the posting is not the sole condition with regard to the status of the account.

It is my opinion that the balance which is properly to be used in applying the intervenor's theory here is the third of those above described; that is, that which is shown by deducting all withdrawals posted during the day from the opening balance, without crediting deposits for the day.

The second above described, which results from periodical postings during the day of deposits and withdrawals,

after crediting the opening balance, is not properly usable, for the reason that under the bank's practice, as above detailed, such balance disregards the actual order of deposits and withdrawals in point of time, and consequently does not reflect the true state of the account at any time.

The first above described, the so-called closing balance, is not usable, for the reason that by its nature it necessarily disregards the actual order of deposits and withdrawals in point of time, and consequently does not reflect the true state of the account at any time since the previous closing balance. To take it as an accurate reflection, it must be assumed that at the moment of each withdrawal, deposits had been received in an amount sufficient to leave a balance at least equal to that resulting from the whole day's transactions. Unless such an assumption is imperative, there is an equal likelihood that at any moment of the day the deposits previously received and the withdrawals then made may have produced a balance less than that resulting from the whole day's transactions, down to zero. Admittedly, the intervenor is not entitled to the benefit of a replenishment of the account after its reduction or exhaustion; yet the closing balance would necessarily yield that benefit, if during the day the account had been reduced or exhausted. Under the burden of proof which is on the intervenor, it cannot avail itself of the assumption which is implicit in the closing balance, in default of that direct evidence which might have been provided by the striking of time-regarding balances during the day. The failure of the bank to strike balances of that conclusive character might, perhaps, in another situation, afford some reason for looking to the closing balances, as the best evidence of which the case admits, in view of banking custom; but in the present situation the intervenor, in

tracing a trust fund into and out of a common account, is bound to better proof than that indicated, and finds it at hand in the facts which support the third description of balance. The other two being inadmissible, the intervenor must content itself with the third, else it must be without any proof at all.

“It is indispensable . . . that clear proof be made that the trust property or its proceeds went into a specific fund or into a specific identified piece of property.” (Empire State Surety Co. v. Carroll County, 194 Fed. 593, 604, C. C. A. 8.) “No doubt the individual whose property has been converted has a high equity and is entitled to certain well-settled presumptions; but we cannot assent to the proposition that he may trace his money into any specific fund or security merely by inferences based on presumptions without substantive testimony to sustain them. The burden of proof is on the claimant at the outset; it rests upon him at the close of the case.” (In re Brown, 193 Fed. 24, 29, C. C. A. 2.) “The burden of proof was upon the claimant to establish its ownership of the fund.” (First Nat. Bank v. Littlefield, 226 U. S. 110, 57 L. ed. 145, affirming In re Brown.) “They were practically asserting title to \$9,600.00, said to have been traced into stock in the possession of the trustee. Like all other persons similarly situated, they were under the burden of proving their title. If they were unable to carry the burden of identifying the fund as representing the proceeds of their Interborough stock, their claim must fail. If their evidence left the matter of identification in doubt, the doubt must be resolved in favor of the trustee, who represents all of the creditors of Brown & Company, some of whom appear to have suffered in the same way. Like them, the appellants must be remitted to

the general fund.” (Schuyler v. Littlefield, 232 U. S. 707, 58 L. ed. 807, affirming *In re Brown*.)

This burden relates to the actual, not the presumptive, balance. The actual order of withdrawals and deposits in point of time is therefore material. If the postings faithfully observe that order, actual balances will result. But they do not observe it in the present case, and it is necessary therefore to seek the fact elsewhere. It is not correct to say that the relation of debtor and creditor arises between the bank and its depositor only when the items are posted. When a depositor hands in a dollar bill, and the teller takes it, the bank immediately owes him one dollar. The indebtedness is not postponed to, nor conditional upon, the bookkeeper's act in noting it on a ledger. If the bookkeeper should never enter it at all, the depositor could nevertheless sue and recover it. The same applies to checks, conversely. If the bank should pay a check for fifty cents, it would be entitled to offset it in the depositor's suit for one dollar, whether the bookkeeper had ever noted it on the ledger or not. The question in both cases is one of fact, not of bookkeeping. Thus, in *In re Brown*, 193 Fed. 24, 28. the court, after referring to the bank's books, said: “The officers of the bank, however, testified that the order in which the entries of debit and credit were made in the books was not necessarily the order in which the separate transactions actually took place. Much testimony was taken in the effort to establish the real sequence of events.” And the court proceeded to find the real, as distinguished from the recorded, sequence of events. We are equally concerned here with the real sequence.

It is true that in *In re Brown*, the court said: “We are clearly of the opinion that when the question is as to the disposition of a fund in a bank account, the time when

certification is signed and noted by the bank is the significant time; it is then that the credit items which make up the balance of account are segregated by the bank as against the obligation assumed by certification. So long as such certification is outstanding, the bank would not allow any of the money thus appropriated to be drawn out." But this really fortifies the position above taken, because it evidently means that the bank, in certifying a check, looks to the actual state of the account at the time, and that it adheres to this afterwards when new checks come in. This accords with the actual practice of the bank in the present case; for the evidence here is that the bank, in certifying checks and in paying checks over the counter, looks, not alone to the entries on the books, but to the unposted deposits and checks as well. The position of the court in *In re Brown* on the necessity for regarding the actual order of deposits and withdrawals is plainly declared by the following language:

"Moreover, it is not enough to show that there were morning and afternoon balances for several successive days large enough to cover the amount of money which was improperly converted. It might very well be that on any one day checks were presented which exhausted the morning balance and its accretions, in which event these moneys would have been dissipated. We are not prepared to assent to the proposition that subsequent deposits are to be taken as having been made to make good claimant's money thus drawn and spent. Board of Commissioners v. Strawn, 157 Fed. 51. . . . Both of them" (the Master and the District Judge) "had the same understanding of the law as that above expressed, viz., that the first check drawn on any given day might sweep away the balance carried over, and that it would be the merest speculation to

assume that subsequent deposits restored the original situation.”

This disposes of any conception of the closing balance as usable for the intervenor's purpose. It disposes of any contention that the order of time may be disregarded in an inquiry of this sort. It affirms, what appears to be conceded here, that subsequent deposits do not restore a trust fund once reduced or exhausted; on which, among many authorities, may be mentioned Schuyler v. Littlefield, 232 U. S. 707, 58 L. ed. 806, and the cases there cited.

The result of the foregoing is that the claim must fail, unless there is a minimum situation upon which the intervenor may rely; that is, a situation which assumes an order of deposits and withdrawals which at the worst must have occurred. Such a situation presents itself in a case where no deposits are made during the day in question, until all withdrawals of that day have been effected. In that case, the order of withdrawals is indifferent, as they all precede the deposits. Now, it is a fact that withdrawals and deposits occurred each day, and that there was always an opening balance; whence some sort of balance, on one side or the other, continually resulted. This balance cannot be disregarded altogether, if there is a way of regarding it without detriment to defendants' position, correctly maintained as above stated. This position, that the time order must be observed, is preserved, and the proven existence of balances of some sort is recognized, by treating the deposits of the day as coming in after the withdrawals. As said by intervenor's brief, it "estab-

lishes a minimum balance for each day below which it was impossible for the balance to have gone." The intervenor is entitled to no more, and the defendants must concede so much.

The following calculation of the amounts for which, under the intervenor's theory, a trust should be declared in the various properties respectively, is accordingly based upon low balances resulting from the deduction of withdrawals for the day from the opening balance, without crediting deposits for the day.

<u>Period from First Deposit to Second Deposit</u>		
Nov. 13, 1929, First Deposit	\$750,000.00	
	<hr/>	
Nov. 30, 1929, First Payment on property	95,040.00	
	=====	
Low balance Nov. 13-30		\$ 93,635.65
(a) Trust in Parcel 1 (payment \$ 500.00)	492.60	
(b) Trust in Parcel 2 (payment 50,000.00)	49,261.20	
(c) Trust in Parcels 3 and 4 (payment 44,540.00)	43,881.85	
	<hr/>	
	(95,040.00)	93,635.65
		<hr/>
Credit remaining on low balance		0.00
		=====

<u>Period from Second Deposit to Third Deposit</u>		
Jan. 20, 1930, Second Deposit		\$200,000.00
Jan. 27, 1930, First Payment on Property	\$ 500.00	
	<hr/>	
Low balance Jan. 20-27	308,662.67	
	=====	
(d) Trust in Parcel 5 (payment=)		500.00
		<hr/>
Credit remaining on trust deposit		\$199,500.00

Jan 29, 1930, Second Payment on Property	271,202.08	
	<hr/>	
Low balance Jan. 27-29	572,859.21	
	<hr/> <hr/>	
(e) Trust in Parcel 2 (payment \$ 50,000.00)	36,780.70	
(f) Trust in Parcel 7 (payment 221,202.08)	162,719.30	
	<hr/>	
	(271,202.08)	\$199,500.00
		<hr/>
Credit remaining on trust deposit		0.00
		<hr/> <hr/>

Period from Third Deposit to Fourth Deposit

Feb. 15, 1930, Third Deposit	\$500,000.00	
Less: Feb. 17, repayment on account	100,000.00	
	<hr/>	
	400,000.00	
Payment on Property, none,	0.00	
Low balance Feb. 15 to Feb. 25 (Fourth Deposit)		0.00
Trust in Property, none,		0.00
		<hr/>
Credit remaining on low balance		0.00
		<hr/> <hr/>

Period from Fourth Deposit to Fifth Deposit

Feb. 25, 1930, Fourth Deposit		\$100,000.00
Payment on Property, none,	\$ 0.00	
Low balance Feb. 25 to Feb. 27 (Fifth Deposit)	204,138.29	
Trust in Property, none,		0.00
		<hr/>
Credit remaining on trust deposit		\$100,000.00

Period from Fifth Deposit to Sixth Deposit

Feb. 27, 1930, Fifth Deposit		\$100,000.00
		<hr/>
		\$200,000.00

Mar. 1, 1930, First Payment on Property	\$ 82,332.84	
	<hr/>	
Low balance Feb. 27-Mar. 1	386,272.73	
	=====	
(g) Trust in Parcel 6 (Payment=)	\$ 34,332.84	
(h) Trust in Parcels 3 and 4 (Payment=)	48,000.00	\$ 82,332.84
	<hr/>	<hr/>
Credit remaining on trust deposit		\$117,667.16
Mar. 5, 1930, Second Payment on Property	\$ 10,625.00	
	<hr/>	
Low balance Mar. 1-5	\$239,919.57	
	=====	
(i) Trust in Parcel 8 (Payment=)		10,625.00
		<hr/>
Credit remaining on trust deposit		\$107,042.16
		=====
Mar. 12, 1930, Third Payment on Property	50,000.00	
Low balance Mar. 5-12		17,400.43
(j) Trust in Parcel 2 (Payment \$50,000.00)		17,400.43
		<hr/>
Credit remaining on low balance		0.00
		=====
<u>Period from Sixth and Last Deposit</u>		
June 6, 1930, Sixth Deposit	\$ 75,000.00	
	<hr/>	
June 25, 1930, First Payment on Property	34,332.43	
	=====	
Low balance June 6-25		0.00
Trust in Property, none		0.00
		<hr/>
Credit remaining on low balance		0.00
		=====

Note.—Inasmuch as the theory assumes that withdrawals for the day (including payment on property) precede deposits for the day (including deposit of so-called trust money), the period for each low balance is fixed as follows: From a deposit to a payment, exclude the date of each. From a deposit to a deposit, exclude the date of the initial deposit and include the date of the next deposit. From a payment to a payment, include the date of the initial payment and exclude the date of the next payment.

SUMMARY

Assuming the propriety of the theory and method employed, assuming the existence of a trust relation, and assuming that a trust in identified property results from the foregoing application of said theory and method (none of which is decided at this stage of the findings), the amount in each instance is as follows:

Parcel 1	(a)	\$	492.60
Parcel 2:	(b)	\$	49,261.20
	(e)		36,780.70
	(j)		17,400.43
			<u>103,442.33</u>
Parcels 3			
and 4:	(c)		43,881.85
	(h)		48,000.00
			91,881.85
Parcel 5	(d)		500.00
Parcel 6	(g)		34,332.84
Parcel 7	(f)		162,719.30
Parcel 8	(i)		10,625.00
			<u><u>\$403,993.92</u></u>

Identification of Property

Parcel 1: Real property, known as "Franklin & Vermont Service Station," in the city of Los Angeles. For description see Receiver's Exhibit F, page 1.

Parcel 2: Leaseholds known as the Delaney Producing Property, Los Angeles County, California. For description see said exhibit, page 28 et seq.

Parcels 3 and 4: Ten storage tanks, of which five are located on property known as the Hottenroth property,

adjoining the Rioco Refinery, at Long Beach, Los Angeles County, California, and five are located on property known as the Hunstock property, adjoining said Rioco Refinery. For description of said tanks and of the real property on which they are located, see said exhibit, pages 2 and 3. It does not appear that the tanks are a part of the realty, and it is accordingly found that they are not. Parcels 3 and 4 therefore comprise the ten tanks, but not the realty.

Parcel 5: Real property, known as the Mull property, in Sacramento County, California. For description, see said exhibit, page 19.

Parcel 6: Vapor Recovery Plant, located on Parcel No. 3, of the Watson Refinery land, in Los Angeles County, California. For description of the land on which this plant is located, see said exhibit, commencing at bottom of page 25. It does not appear that this plant is a part of the realty, and it is accordingly found that it is not. Parcel 6 therefore comprises the plant, but not the realty.

Parcel 7: 106,000 shares of stock of Universal Consolidated Oil Company, represented by the following certificates issued to Richfield Oil Company of California: No. LX26, February 13, 1930, 42,500 shares; No. LX27, February 14, 1930, 50,000 shares; No. LX28, February 14, 1930, 2,000 shares; No. LX32, March 10, 1930, 11,500 shares.

Parcel 8: 5,100 shares of stock of Universal Consolidated Oil Company, represented by the following certificate issued to Richfield Oil Company of California: No. LX31, March 7, 1930.

No determination of title or ownership is made in reference to any of the above properties. The findings relate

only to such right, title and interest, if any, as Richfield Oil Company of California and its receiver may have.

The Richfield receiver has made payments on account of the purchase price of Parcels 1, 2, and 5, respectively. The data in reference thereto are as follows:

	Total purchase price	:	Payments before receivership	:	Payments since receivership	:	Traced on above theory
Parcel 1—	\$ 63,856.24	:	\$ 11,500.00	:	\$22,500.00	:	\$ 492.60
Parcel 2—	3,670,638.33	:	540,000.00	:	87,123.82	:	103,442.33
Parcel 5—	14,200.00	:	8,000.00	:	6,000.00	:	500.00

Parcel 1 was conveyed to Richfield by grant deed dated February 18, 1927, and contemporaneously Richfield gave the vendor a note, secured by mortgage on the property, for the unpaid balance of the purchase price. At January 15, 1931, the date of the appointment of the receiver, \$22,500.00 remained unpaid on the principal of said note, and the receiver has since paid that sum.

Parcel 2 was purchased by Richfield under a conditional sales contract dated August 1, 1927. Bills of sale and assignments of leases were deposited in escrow by the vendor in 1927, and were delivered to the receiver on payment of the balance of the principal of the purchase price, which payment was made by the receiver, in the sum of \$87,123.82.

Parcel 5 was purchased by Richfield from A. M. Mull, under an option dated November 22, 1929, taken up by an agreement of purchase dated April 7, 1930, for a price of \$14,200.00, of which \$4,700.00 had been paid before said April 7, 1930, and \$3,500.00 of which was payable by the assumption by Richfield of a note in that principal sum, secured by trust deed on the property, which had been given by Mull to Moore; and the remainder of the purchase price was payable thereafter by Rich-

field, of which the principal sum of \$2,500.00 remained unpaid at the time of the appointment of the receiver. The receiver has paid the holder of said note the aforesaid \$3,500.00, in full thereof, and has paid to Mull the aforesaid \$2,500.00, in full of the remainder of said deferred payment.

Parcel 2 is not listed in the Exhibit attached to the bill in intervention, but by consent at the hearing that parcel is deemed to be included without the formality of amendment.

The pleadings admit as follows in reference to the bond indenture: Security-First National Bank of Los Angeles has filed its bill of complaint herein to foreclose a mortgage and trust indenture of the Richfield Oil Company of California of date May 1, 1929, securing an authorized bonded indebtedness in the aggregate principal amount of \$75,000,000.00, which mortgage and trust indenture purports to be a mortgage and lien upon all of the assets and properties of Richfield, including all of the assets into which the money in question is here sought to be traced. Richfield has issued and outstanding, first mortgage bonds secured by said mortgage and trust indenture in an amount in excess of \$24,000,000.00. Richfield has defaulted, and said trustee has declared said default and instituted said proceeding for the purpose of having said mortgage and trust indenture declared a valid and subsisting first lien and charge on all of the properties and assets of Richfield, including all of the assets into which the money in question is here sought to be traced, prior and superior to the interests, liens, and claims of all persons, including Universal; and the trustee asks that all of said property and assets be sold without right of redemption.

CONCLUSIONS

—I—

CHARACTER OF THE TRANSACTION

On its face, the transaction bore the indicia of a loan; that is, an advance of money, to be repaid with interest. The principal was set up on the books of each company. A repayment on account was likewise set up, as was also an exchange of checks representing a repayment and a refund thereof. Interest charges were invoiced periodically to Richfield and approved by it, and one instalment of interest was paid. The interest charges were set up on Universal's books periodically, and the single payment of interest was there credited. Universal's secretary-treasurer and its bookkeeper regarded the transaction, at the time, as a loan. The transaction was included in Universal's certified balance sheet of December 31, 1929, presented at the stockholders' meeting of April 15, 1930, in the general lump designation of "Demand Loans" or "Call Loans." The statement given by Universal's secretary-treasurer, in January, 1930, to an inquirer, designated the account as "Call—1 day notice." It is true that no note was given, but a note is not an essential condition of a loan.

If this were all, there would be an end of intervenor's case. Other considerations remain, however, and these are found as follows.

The executives of Richfield had given attention to Universal during some four years. They finally developed an interest, not only in Universal's producing properties, but in its money, of which a million seven hundred thousand dollars was in liquid investments. They contemplated procuring the use of that money for Richfield. Their

company owed banks at the time over ten million dollars; and while that indebtedness implies a high credit standing at the time it was incurred, it does not appear when it originated; and it does appear that seventeen months after its first agreement to buy Universal stock, and seven months after receipt from Universal of the last money involved here, the company went into the hands of a receiver as an insolvent. The expressed contemplation of Universal's money as a source of Richfield financing, and the immediate use of seven hundred and seventy-five thousand dollars thereof as soon as Richfield was in a position to procure it, together with the fact of its own enormous indebtedness and its rapidly developing insolvency, certify to its need of Universal's money.

In that situation, one of its directors negotiated for the Universal stock, and procured it, partly for Richfield, and partly for a syndicate in whose profits Richfield was to participate. Of its cash payment for the original block of stock, Richfield procured from Universal, within seven weeks after, an amount equal to ninety-four per cent. Of its cash payment for the second block, it procured from Universal, nine days before the payment, an amount equal to ninety per cent. In other words, while paying \$1,043,702.08 for the stock, it procured from Universal, at the times aforesaid, \$975,000.00. About two weeks after payment for the second block, it procured an additional \$500,000.00, while the cash payment for the third block, made three weeks later, amounted to \$10,625.00, and the amount of the previous payments over the previous procurements was \$68,702.08, a total of \$79,327.08, leaving then, of the \$500,000.00, uncompensated by any cash cost of stock, \$420,672.92 to the good.

This was made feasible by a condition of the original purchase agreement, under which Richfield immediately assumed control of Universal. Despite its minority stock interest and its minority representation on the board at the time, there is no doubt about the control. The chairman of Richfield's board, who was then also president of Universal, declared the fact in his report of October 8, 1929, to the Universal stockholders, about a month before Richfield procured \$775,000.00 from Universal's treasury.

This control was immediately manifested by the withdrawal, within a month, of \$1,100,000.00 of Universal's money from call loans in New York. This was done by order of Richfield men, and was done for the purpose of procuring Richfield financing; a first step in effecting one of the principal objects initially conceived on its part. Thereafter, all steps in the procurement of the money for its own use were directed and taken by persons who were, if members of the Universal organization, also members of the Richfield organization, with the assistance of Richfield men who were not members of the Universal organization. Universal's secretary-treasurer and its bookkeeper, who attended to clerical and mechanical details, took their orders from those who belonged to the Richfield organization, and never presumed to exercise any discretion of their own. Except for these two, nobody in the Universal organization, unconnected with Richfield, knew what was going on. No discussion or action ever took place at any meeting of the Universal board. Those directors of Universal who were not associated with Richfield displayed no interest in the immense cash surplus in their company's treasury, or its disposition; the whole matter was left to the uncontrolled discretion of the Richfield men.

In several instances, these latter actively attempted concealment. Their restoration of \$600,000.00 on the morning before the Universal stockholders' meeting and their resumption of the same sum immediately after the meeting could have had no other purpose. The refusal to disclose to a persistent inquirer the identity of the borrower, and the failure to answer a stockholder who wrote for information, are further instances. Taken all together, they constituted a confession of vulnerability.

While Universal had generally, apart from this money, sufficient funds with which to pay its operating expenses and dividends, and discount its bills, there was a time when, on account of these transactions, it was unable to meet its payroll or discount its bills, and Richfield had to come to its aid; and at one time it had to pay its dividend to Richfield with a book credit and to call on Richfield for money to help in paying the dividend to others; and at another time it was without money with which to pay a dividend that had been earned.

Previously, loans on call in New York had been made by direction of the president and the secretary of Universal, without any action by the board, and a loan on a note had been so made; but in none of these cases was any person interested as borrower who had any connection with Universal.

The question is, whether in the foregoing situation, what would otherwise be deemed a loan must here be deemed a misappropriation. My opinion is that it must.

Under the conditions proven, the burden is on the defense. This requires the defense to show that the transaction was openly and honestly entered into, that it was fair and just, that it was in the true interest of Universal, and that the consideration was adequate. *Geddes v. Ana-*

conda C. M. Co., 254 U. S. 590, 65 L. ed. 425, 432; *Corisicana Nat. Bank v. Johnson*, 251 U. S. 68, 64 L. ed. 141, 155; *Mumford v. Ecuador Dev. Co.*, 111 Fed. 639, 643, C. C. N. Y.; *McCaffrey v. Elliott*, 47 Fed. (2d), 72, 73, C. C. A. 5; *Finefrock v. Kenova M. Car Co.*, 22 Fed. (2d), 627, 632, C. C. A. 4. This burden has not been sustained.

The conduct of the promoters of the transaction must be subjected to the closest scrutiny, in the light of their opportunity for serving themselves. The temptation which usually attends the possession of power, to exercise it selfishly, raises a suspicion which they must meet by a clear showing of the utmost good faith. Their acts are to be gauged by principles of morality, and their motives by their acts. If their use of power is selfish, or unfair, or oppressive, or disregarding of interests which they are bound to protect, the color of regularity in the form will not save them from the condemnation of equity. *Twin-Lick Oil Co. v. Marbury*, 91 U. S. 587, 23 L. ed. 328, 330; *Mumford v. Ecuador Dev. Co.*, 111 Fed. 639, 643, C. C. N. Y.; *McCaffrey v. Elliott*, 47 Fed. (2d) 72, 73, C. C. A. 5; *Finefrock v. Kenova Mine Car Co.*, 22 Fed. (2d) 627, 632, C. C. A. 4.

A position of power does not of itself necessarily invalidate the possessor's dealings with his corporation, but it imposes upon him a duty commensurate with his power, and consequently the burden of justifying its exercise; and this, whether the possessor is itself a corporation or otherwise. Tested by the principles above outlined, there is in the present case a plain failure of justification.

If a note had been given, it would not of itself have exonerated Richfield, for the court will look through that form to the substance; but in withholding it, Richfield did

less than its duty required. It thereby made sure in its own interest that its obligation should remain substantially frozen in the hands of a controlled creditor, for such a book account would not be readily negotiable. On the other hand, it disadvantaged Universal, in impairing its freedom of disposition of this enormous asset, a freedom which would have been preserved to it by the possession of negotiable notes.

It was the duty of Richfield to have proposed the accommodation to Universal's board, thereby recognizing the right of the minority members (originally in fact a majority) to be heard and if necessary to take preventive measures. This right was wholly disregarded; and, as it proved, it was a right which might well have been exercised. It is true that the other directors were incurious as to the whereabouts of their company's immense surplus, but their negligence does not excuse those who took advantage of it, and the burden which arose between the negligence of one set of directors and the selfishness of the other set is not to be shifted to stockholders who were virtually, between the two, unrepresented. It is not an answer that the making of loans had been previously assumed by certain officers without action of the board, because the officers who made such loans had no interest.

The moneys passed in this case without the slightest knowledge or investigation of the beneficiary's responsibility. No bank would have considered such loans without a financial statement, supported by appraisals. No such information was furnished by Richfield in this instance. If it had been, an honest director (and a majority of the old board still remained when the first money passed) might well have questioned the offered responsibility. Richfield, having the power to take the money

without consulting the disinterested directors, owed a duty to the stockholders to refrain and instead to make a full and fair disclosure of its condition to those charged with the protection of the stockholders. It is reasonable to think that such a disclosure would have resulted, while Richfield representatives constituted only a minority of the board, in a refusal of the accommodation; but in any event the Richfield representatives evidently realized the danger of such action, and in any event the other directors were entitled to an opportunity, whatever the result of that opportunity might have turned out to be.

In defect of a satisfactory showing of responsibility, it was Richfield's duty to provide security, if it could, and if it could not, to decline the accommodation. This was not merely academic. Apart from its failure to make a financial statement, and even on a favorable assumption of worth, the safety of these heavy unsecured accommodations depended to some extent on the goodwill of the banks to which Richfield owed more than ten million dollars. The calling in of these bank loans would have jeopardized the Universal account, even assuming that Richfield owed nothing else. Richfield's duty was to relieve Universal of this participation in a risk which was subject to the will of others, by providing adequate security. In any event, however, a faithful regard to the interests of Universal's stockholders required that in the absence of a plain showing of financial responsibility, security be given by Richfield.

In the absence of these measures of protection, the consideration for the accommodation was entirely inadequate. Mere interest would not be an adequate compensation for the risk. The banks had, besides interest, both protection and compensation in the balances kept with

them, whereby they gained a lien and meanwhile the use of the borrower's money. No such advantage was granted to Universal.

In fact, Richfield, in taking the money, did not even agree to pay interest. Afterwards, it is true, interest charges running at various rates from four per cent to five and one-eighth per cent were recognized by Richfield, and were in fact fixed by Richfield. They were thus fixed after the fact by the borrower without consultation with the lender. Fair dealing required that Richfield by note or otherwise agree with Universal at the time of the accommodation upon the payment of interest at an agreed rate. A matter of such consequence should not have been left either to implication of law or to the will of Richfield. The fluctuating rate fixed by it from time to time and the calm neglect of payments show not only the lack of any definite commitment but the assumption by Richfield of an uncontrolled discretion as to whether, when, and at what rates it might please to pay.

In order to effect the dubious situation above outlined, Richfield vacated a sound one. The recalling of the New York loans was obviously in its own interest and not in that of Universal, though its duty required it to promote the latter's rather than its own.

The self-serving intent appears from the beginning in the nature of the stock transaction, whereby Richfield assured itself of actual control with a minority of the stock, and enabled itself to take out of the Universal treasury, practically contemporaneously, an amount of money almost equal to its payment for the stock. The fact that it acknowledged on the books liability for the money taken does not improve the obviously interested motive; for at least it may be said that it thereby relieved the

immediate pressure on its own treasury and converted, with Universal's own money, into a future obligation what would otherwise have been a present disbursement.

All this was accomplished by means which, considering the standard of conduct to which its position of power bound it, may well be called clandestine. Its failure to consult the board, its failure to advise the opposite directors personally, its failure to disclose the fact in its annual report to the stockholders, its fictitious semblance of restoring a part of the money on the day of the stockholders' meeting, its refusal to answer a point-blank inquiry, all together show, not only a lack of that openness which its position required, but a deliberate course of concealment, and a consequent consciousness of guilt.

The whole proceeding was arbitrary, *ex parte*, and self-interested, pursued in the exercise of irresponsible power, reckless of the consequences to others, and fruitful of injury.

It is held that Richfield occupied a position of trust; that it violated its trust; that it misappropriated the money of its cestui; and that in doing so it was guilty of actual fraud.

The foregoing views are, I think, sustained and, in fact, compelled by the following decisions:

Peters v. Bain, 133 U. S. 670, 33 L. ed. 696, 699; *Geddes v. Anaconda C. M. Co.*, 254 U. S. 590, 65 L. ed. 425, 432; *Wardell v. Union Pacific R. R. Co.*, 103 U. S. 651, 26 L. ed. 509, 511, 512; *Mumford v. Ecuador Dev. Co.*, 111 Fed. 639, 643, C. C. N. Y.; *Ervin v. Oregon Ry. & Nav. Co.*, 27 Fed. 625, C. C. N. Y.; *Jones v. Missouri Edison Electric Co.*, 144 Fed. 765, 771, C. C. A. 8; *Wheeler v. Abilene Nat. Bank Bldg. Co.*, 159 Fed. 391,

394, C. C. A. 8; *Finefrock v. Kenova M. Car Co.*, 22 Fed. (2d), 627, 632, C. C. A. 4; *Stebbins v. Michigan Wheelbarrow & Truck Co.*, 212 Fed. 19, 28, C. C. A. 6; *Saranac & L. P. R. Co. v. Arnold*, 60 N. E., 647, 648, N. Y.; *Riley v. Callahan M. Co.*, 155 Pac. 665, 669, Ida.; *Indian Land & Trust Co. v. Owen*, 162 Pac. 818, 819, Okla.

—II—

EFFECT OF THE TRANSACTION.

The effect was that Richfield held the abstracted moneys in trust for Universal and acquired no title thereto in its own right. *Peters v. Bain*, 133 U. S. 670, 33 L. ed. 696, 699; *Omaha Nat. Bank v. Federal Reserve Bank*, 26 Fed. (2d), 884, 887, C. C. A. 8; *Ervin v. Oregon Ry. & Nav. Co.*, 27 Fed. 625, C. C. N. Y.; *Indian Land & Trust Co. v. Owen*, 162 Pac. 818, Okla.; Cal. Civil Code, section 2224. It is true that under certain circumstances, the transaction of an interested director or majority of directors with the corporation may be merely voidable. *Thomas v. Brownville Etc. RR Co.*, 109 U. S. 522, 27 L. ed. 1018; *Rogers v. Guaranty Trust Co.*, 60 Fed. (2d), 114, 118, C. C. A. 2; *Jones v. Missouri Edison Electric Co.*, 144 Fed. 765, 777, C. C. A. 8; *San Diego v. Pacific Beach Co.*, 112 Cal. 53, 58. But in these cases actual fraud is not involved. The decisions cited recognize this distinction. For instance, in the California case cited, the court said: "In this case there is no actual fraud, either alleged or found; and this distinguishes it from many of the cases cited by appellant." Where, as in the present case, the money is abstracted by actual fraud, it seems to be clear, both upon reason and upon authority, that a trust results. There can be no question here of ratifica-

tion of the fraud. The transaction, constituting as it did a fraudulent misappropriation and breach of trust, could not be ratified, certainly not without unanimous consent of the stockholders on full knowledge. Some point is made of a resolution adopted at the stockholders' meeting on April 15, 1930, approving "the acts of the board and officers as the same appear in the books and records of the corporation." Even if the stockholders could effectively ratify a fraudulent misappropriation of the company's money, 98,079 shares were unrepresented at the meeting, and could not possibly be bound; the proxy-holders who voted nearly all of the represented stock in favor of the resolution were in part the faithless ones themselves and in part those who knew nothing of the matter at all; while the advances did appear on the records, they were buried therein in such a manner that it would have taken an investigation on the part of a stockholder to have discovered them; and in fact, none of the stockholders, except the interested one, knew what appeared on the records respecting this transaction. The blanket "ratification" was rather an additional evidence of bad faith. It was certainly not an effective exoneration of the wrongdoers.

—III—

TRACING THE TRUST MONEY INTO PROPERTY

A trustee deposits trust money in an account containing his own funds, pays for an identified piece of property out of the mixed fund, and afterwards dissipates the remainder. Between the deposit and the payment he has daily deposited his own funds and daily withdrawn from the mixed fund, but the account has never been exhausted. The question is, whether a trust is to be declared in the

identified piece of property for the payment thereon, limited by the amount of the trust money deposited or by the intervening low balance in the account, whichever is less.

The modern development of this subject in equity began in 1879 with the celebrated English case of *In re Hallett's Estate* (*Knatchbull v. Hallett*), on appeal from the Chancery Division, L. R. 13 Ch. Div. 696. A multitude of American decisions have variously construed and applied its principles, with a certain harmony on the underlying points, and some variation in the application. In the present case, the federal appellate decisions are to be looked to, in preference to the state decisions, where the former afford light. *John Deere Plow Co. v. McDavid*, 137 Fed. 802, C. C. A. 8; *Beard v. Independent District*, 88 Fed. 375, C. C. A. 8. On the whole subject, reference is made to an exhaustive annotation by R. T. Kimbrough in 82 A. L. R. (1933), pp. 46-288, which, while dealing specifically with insolvent banks, covers the phases which concern us here.

The ground upon which the cestui is permitted to follow the trust fund into the hands of a receiver is that it belongs to him, whether in the form in which he parted with it or in a substituted form. *Macy v. Roedenbeck*, 227 Fed. 346, 353, C. C. A. 8. Universal is accordingly here in the position of one claiming his own property.

The commingling of a trust fund with other similar funds in a bank does not extinguish the trust or defeat the rights of the cestui to follow and reclaim the trust fund, in its original or in a substituted form; and if the trust money remains in the mixed fund, the confusion merely converts it into a prior charge upon the entire mass. *San Diego County v. California Nat. Bank*, 52

Fed. 59, 62, C. C. S. D. Cal.; *Frelinghuysen v. Nugent*, 36 Fed. 229, 239, C. C. D. N. J.; *American Can Co. v. Williams*, 176 Fed 816, 819, C. C. W. D. N. Y., affirmed 178 Fed. 420, 422, C. C. A. 2; *Brennan v. Tillinghast*, 201 Fed. 609, 612, C. C. A. 6; *Ellerbe v. Studebaker Corp.*, 21 Fed. (2d) 993, C. C. A. 4; *City of Miami v. First Nat. Bank*, 58 Fed. (2d) 561, C. C. A. 5.

No change in the state or form of the trust property can divest it of its trust character; a court of equity will follow it through all the transmutations it may undergo in the hands of the trustee, and it may be pursued and recovered by the beneficial owner as long as it can be traced or identified, either in its original state or in some altered or substituted form. And this applies as well after the insolvency of the trustee as before. *First Nat. Bank v. Armstrong*, 36 Fed. 59, 61, 62, C. C. S. D. Ohio; *St. Augustine Paint Co. v. McNair*, 59 Fed. (2d) 755, 757, D. C. S. D. Fla.; *Kemp v. Elmer Co.*, 56 Fed. (2d) 657, D. C. S. D. Cal.; *In re J. M. Acheson Co*, 170 Fed 427, 429, C. C. A. 9; *Board v. Strawn*, 157 Fed. 49, C. C. A. 6; *Peters v. Bain*, 133 U. S. 670, 33 L. ed. 696, 699.

Where the recovery concerns the mixed fund itself, the whole remaining fund will be charged, not exceeding the lowest intervening amount thereof, and provided it has not meanwhile been exhausted. This proviso is for the reason that if the whole mixed fund is once gone, the trust money is gone with it, and subsequent repletion from free funds does not restore the trust fund; and the limitation to the lowest intervening amount results from the same principle. *Board v. Strawn*, 157 Fed. 49, 51, C. C. A. 6; *Blumenfeld v. Union Nat. Bank*, 38 Fed. (2d) 455, C. C. A. 10; *Schuyler v. Littlefield*, 232 U. S. 707, 58 L. ed. 806; *In re Brown*, 193 Fed. 24, C. C. A. 2; *In re*

Bolognesi & Co., 254 Fed. 770, C. C. A. 2. When the aforesaid conditions are shown, that is, money in the mixed fund, no intervening exhaustion, an intervening low balance, the tracing of the trust fund is complete, without anything more specific; and this satisfies the requirement that clear proof be made that the trust money went into and remains in a specific fund. *Empire State Surety Co. v. Carroll County*, 194 Fed. 593, C. C. A. 8; *Brennan v. Tillinghast*, 201 Fed. 609, C. C. A. 6; *Macy v. Roedenbeck*, 227 Fed. 346, C. C. A. 8; *American Surety Co. v. Jackson*, 24 Fed. (2d) 768, C. C. A. 9; *Central Nat. Bank v. Conn. Mut. Life Ins Co.*, 104 U. S., 14 Otto 54, 26 L. ed. 693 (1881); *In re Hallett's Estate*, L. R. 13 Ch. Div. 696, (1879). On this showing, the burden shifts to the trustee to show that in fact the disbursements were from the trust fund, and that the trust fund was so dissipated or lost. And this burden rests upon a receiver as well as upon the party himself. *American Surety Co. v. Jackson*, 24 Fed. (2d) 768, C. C. A. 9; *Fiman v. State of So. Dakota*, 29 Fed. (2d) 776, C. C. A. 8 (cert. denied 279 U. S. 841, 73 L. ed. 987); *Smith v. Mottley*, 150 Fed. 266, C. C. A. 6.

The foregoing rules, which, so far as they relate to the mixed fund itself as the subject of the charge, are established in the federal courts without dissent, have their basis in the principle, which, ever since the Hallett case, is equally well established, that a faithless fiduciary will not be heard to say in his own behalf and interest that his disbursements from the common fund were misappropriations of trust money rather than lawful expenditures of his own; else he would be rewarded, and his beneficiary penalized, by allowing him to assert his own misconduct. Accordingly, what is left in the mixed fund must be attributed first to the trust, and afterwards to himself.

This is often called a presumption or fiction, but it is not truly so; it is a true equitable estoppel, and on that ground needs no support in any supposed intention of the trustee. The nature of this principle as an estoppel, and not as a mere presumption of intention, appears throughout the discussion by the judges in the Hallett case, and is stated by Justice Thesiger in that case in the phrase, "*Allegans suam turpitudinem non est audiendus.*" Since the Hallett case, the rule at law, that the first money in is the first money out, as declared in Clayton's Case in 1816, in England, no longer applies between a fiduciary and his cestui, though it still applies between cestuis themselves. *In re Hallett's Estate*, L. R. 13 Ch. Div. 696 (1879); *Central Nat. Bank v. Conn. Mut. Life Ins. Co.*, 104 U. S., 14 Otto 54, 26 L. ed. 693 (1881); *American Surety Co. v. Jackson*, 24 Fed. (2d) 768, C. C. A. 9; *Fiman v. State of So. Dakota*, 29 Fed. (2d) 776, C. C. A. 8; *Empire State Surety Co. v. Carroll County*, 194 Fed. 593, C. C. A. 8; *Brennan v. Tillinghast*, 201 Fed. 609, C. C. A. 6; and many others. The federal courts without exception now follow the rule of the Hallett case, that the trustee spends his own money first. 82 A. L. R. at 155, statement by annotator.

The requirement of clear and positive identification being satisfied by the sort of proof above described, where the object is the fund of money, the question now arrives, what sort of proof will satisfy the like requirement, where the object is property other than the fund of money.

Undoubtedly, if the trust money is earmarked, as by segregation, and it appears that it went into a specific piece of property, of whatever kind, the tracing is complete, and a trust results in the substituted property. *Peters v. Bain*, 133 U. S. 670, 33 L. ed. 696. But where

the property is purchased with money out of a fluctuating mixed fund, afterwards dissipated, questions arise which are not so clearly settled as those which pertain to an undissipated fund. These questions, with my views thereon, are as follows.

(a) It is contended that the estoppel above alluded to applies to disbursements for all objects alike, the purchase of land as well as the purchase of an ice-cream soda. Applying this theory to the present case, Richfield must be held to have invested its own money in the property in question, and to have dissipated the trust money afterwards; because the conversion of trust money into other property would be a violation of its duty, and such a breach must not be imputed to it. Thus Richfield makes a clear gain, and the estoppel which was intended to protect the victim defeats him. If this development is necessary, equity may still refuse to follow it; but in my opinion it proceeds from a fallacy, and is not necessary. On the contrary, it is a misapplication of the doctrine, and is indeed inconsistent therewith; for the doctrine concerns the dissipation, not the retention, of the fund, and it is immaterial whether it be retained in one form or another.

When the trust money is segregated and so traced into property, it is admitted by all the cases (*Peters v. Bain*, 33 L. ed. 696, for example), that the property is but a substituted form, and takes the place of the money. If the owned money were similarly segregated and traced into property, the same would of course be true; the property would be but a substituted form of the owned money. If there is no segregation, but the mixed fund is traced into property, the same still remains true; the property is but a substituted form of the mixed fund. If there was any trust money in the mixed fund, it remains in the sub-

stituted mixed form; and it remains there in the same order in which it lay in the mixed fund itself: first for the benefit of the cestui, and first to be retained for him, and only afterwards for the benefit of the holder, and only afterwards to be retained for him. The cestui's money has not been dissipated at all; on the contrary, it has been retained for him, but in another form. The holder of the mixed fund might invest the whole thereof in bonds at the same time; if the contention were sound, that would defeat the cestui's title as effectually as would a dissipation of the whole fund at one turn of the roulette wheel; but it is obvious that no such result would follow; the cestui's money would still be in the bonds, to the same extent that it was in the fund. In the case of a partially invested mixed fund, the estoppel does not come into play at all, any more than it does in the case of a wholly invested or wholly undissipated fund. It is accordingly repugnant to the rule itself, and certainly not a necessary consequence thereof, to reward the guilty and penalize the innocent in the manner proposed.

Moreover, if there were such a thing as an estoppel which concludes the opposite party instead of the one nominally estopped, it should be frankly abandoned by a court of equity. Another rule, equally appealing to the conscience, should have effect: the rule which requires the fiduciary, in such a case, to do equity. Nothing could be more abhorrent to the conscience than that the fiduciary should set aside to himself the gain and to his beneficiary the loss. The difficulty is created by himself; the burden of it should be on him. To do equity, he must concede the first fruits to the beneficiary. Before he can be heard at all, he must be required to do so.

The law of England, where the estoppel doctrine originated, is settled in accordance with the foregoing views. In the case of *In re Oatway*, in the Chancery Division (1902), L. R. 2 Ch. Div. 356, a fiduciary invested money from the mixed account in corporate shares, dissipated the remainder, and died. The shares were held to belong to the trust. The *Hallett* case was referred to, and Sir Matthew Joyce said: "It is a principle settled as far back as the time of the Year Books that, whatever alteration of form any property may undergo, the true owner is entitled to seize it in its new shape if he can prove the identity of the original material. . . . It is, in my opinion, equally clear that when any of the money drawn out has been invested, and the investment remains in the name or under the control of the trustee, the rest of the balance having been afterwards dissipated by him, he cannot maintain that the investment which remains represents his own money alone, and that what has been spent and can no longer be traced and recovered was the money belonging to the trust." (It was objected that his own share of the account exceeded £2137, the price of the shares, and "that he was therefore entitled to withdraw that sum, and might rightly apply it for his own purposes.") "To this I answer that he never was entitled to withdraw the £2137 from the account, or, at all events, that he could not be entitled to take that sum from the account and hold it or the investment made therewith, freed from the charge in favour of the trust, unless or until the trust money paid into the account had been first restored, and the trust fund reinstated by due investment of the money in the joint names of the proper trustees, which never was done."

The same position is taken by the Circuit Court of Appeals in the 6th Circuit, in *Brennan v. Tillinghast*, 201

Fed. 609, 613, 614 (1913), in which the question directly arose. A fiduciary bank had the trust money on deposit with another bank in a mixed account. The former sold drafts on this account, in less than the balance, and received the amount thereof in cash from the purchaser. It was held that this constituted, in effect, a transfer of so much of the trust fund in cash to the vaults of the first mentioned bank, and that "this portion of the trust fund must be deemed to have remained in the vaults of" (said bank) "as part of the trust fund, in cash, until it came into the possession of the receiver." After describing the rule of the Hallett case, Judge Sanford said: "It is furthermore clear that this rule of presumption has no application where the evidence shows that the first moneys drawn out of the mingled fund by the tort-feasor were not in fact dissipated by him at all, but were merely transferred, in a substituted form, to another fund retained in his own possession. In such case, it must be held that the trust attaches to the substituted form in which the property is retained by the tort-feasor, and that the right to follow the trust in such form is not lost by reason of the fact that the tort-feasor thereafter draws out and spends for his own purposes the balance of the fund in which the trust money was originally mingled. The English case of *In re Oatway*, L. R. 2 Ch. 356, 359, directly sustains this view."

The Circuit Court for the Southern District of New York had previously, in 1911, taken the same view. In *Primeau v. Granfield*, 184 Fed. 480, 484, Judge Hand, referring to the Hallett case, said: "The language about presumed intent in *Knatchbull v. Hallett*, supra, which Sir George Jessel laid down with his customary vigor, was merely a way of giving an explanation by fiction of the

right of the beneficiary to elect to regard his right as a lien. That it is a fiction appears clearly enough in this case where Granfield could have had no intention about the investments as he meant to use all the money for himself anyway. To say that in such a case he will be 'presumed' to intend to take his own money out first is merely a disingenuous way common enough, to avoid laying down a rule upon the matter. This fiction in *Re Oatway* (1903) 2 Ch. Div. 356, would have brought the usual injustice which fictions do bring, when pressed logically to their conclusion. Logically, the trustee's widow, in that case, was quite right in claiming the first withdrawal, although the trustee had invested it profitably, and had subsequently wasted all of the fund which had remained in the bank. That was, of course, too much for the sense of justice of the court which awarded to the wronged beneficiary the investment, intimating that the rule in *Knatchbull v. Hallett*, *supra*, applied only where the withdrawals were actually spent and disappeared. If to that rule be added the qualification that if the first withdrawals be invested in losing ventures, then the beneficiary is to have a lien, if he likes, till he uses up that whole investment, and then may elect to fall back for the balance upon the original mixed account from which the withdrawal was made, there is no objection, but it is a very clumsy way of saying that he may elect to accept the investment if he likes, or to reject it. The last is the only rule which will preserve to the beneficiary the option which he has when the investment is made wholly with his money. Suppose, as here, that the trustee deposits the money with his own in a bank. That is an investment. We call it a deposit, but we all know that it is only a chose in action. The beneficiary has the right at his election either to be-

come a part owner in this chose in action, or to keep a lien upon it. Suppose he chooses to be a part owner; then, when part of it is released by payment, he is likewise a proportionate co-owner in the money paid. If that money is in turn invested he is a proportionate co-owner in that new investment, and there is no ground why as to that investment likewise he should not have, at his election, the right to become a lienor pro tanto. Sir George Jessel's dictum in his judgment in *Knatchbull v. Hallett* at page 710 did not deny this, if the words are nicely observed. He says that in the case of a purchase with a mixed fund 'the cestui que trust, or beneficial owner, can no longer elect to take the property, because it is no longer bought with the trust money purely and simply.' No one can dissent from that statement of the law. Then he at once follows it by saying that he does have a charge, which, likewise, no one disputes; but he nowhere says that he has only a charge, and may not have pro tanto an ownership. Two chancellors, Lord Brougham and Lord Cottenham, had previously said that the beneficiary might have such an ownership, and later in *Re Oatway* it became apparent that, if not, then very great wrong could be done. Sir George Jessel was a very great equity judge, and no one should lightly differ with him, but there is no reason in this case to impute to him anything of the kind here suggested, or to press the fiction of a presumed intent to a conclusion which is out of harmony with the rights of a beneficiary in the analogous case where there has been no mingling of the funds."

On appeal, the decision in the above cited case was reversed, but only on the ground that both parties were engaged in a joint fraudulent undertaking, and came in with unclean hands; the views of Judge Hand, above

quoted, were not commented on. *Primeau v. Granfield*, 193 Fed. 911, C. C. A. 2; cert. denied 225 U. S. 708, 56 L. ed. 1267.

In *Fiman v. State of So. Dakota*, 29 Fed. (2d), 776, 781, C. C. A. 8, the court recognized the authority of *Brennan v. Tillinghast*, and applied the principle thereof to the tracing of the state's deposits with a bank into the bank's accounts with its correspondent banks. The court said: "Nor can we see any reason why the state could not trace its funds into the accounts of the correspondent banks and treat them as separate accounts from the general cash assets of the bank. See *Brennan v. Tillinghast*, (C. C. A.) 201 Fed. 609. . . . The tracing of funds into the several correspondent banks was direct and certain, and in the absence of showing of dissipation, came into the hands of the receiver, and plaintiff was entitled to that amount upon which it had a lien in the commingled fund."

The author of the excellent annotation in 82 A. L. R., says at page 160: "The presumption in question, being based upon a fiction invented solely for the protection of the cestui que trust, should not be applied in such manner as to defeat his rights. The application of the presumption would have that effect in a case where the bank withdrew and preserved, by investment or in another fund, a part of the fund with which the trust fund had been commingled, and subsequently dissipated the residue of the commingled fund; and the better view, as pointed out by Professor Scott in 27 *Harvard L. Rev.* 125, 132, is that the part of the common fund left after the first withdrawal, and later dissipated by the bank, will not be presumed to be or represent the trust fund. In other words, in

such case, the part first drawn out will not be presumed to have belonged to the trustee."

With these views I agree, and, in the existing absence of any pronouncement from the Circuit Court of Appeals in the 9th Circuit, I think they should be given effect, unless the Supreme Court of the United States has clearly pronounced otherwise. If any disagreement should be found among the Circuit Courts of Appeals, the position adopted in the 6th Circuit, in *Brennan v. Tillinghast*, *supra*, should be adopted here, because, as it seems to me, it is thoroughly sound.

The only case in the Supreme Court, having any immediate bearing, is *Peters v. Bain*, 133 U. S. 670, 33 L. ed. 696 (1889), and I do not think this case compels a reversal of the views above taken. A private banking firm, by a fraudulent abuse of power, absorbed moneys from a national bank. "The money received by the firm from the bank was generally mingled with that which was got from other sources, and it has been impossible to trace it directly into property now in the hands of the assignees" of the firm, except in some specified instances, where the property was "purchased with moneys that can be identified as belonging to the bank." As to the latter, a trust was declared by the Court; and the identification in those instances was direct and specific, because "no money was used in these purchases other than such as was taken directly from the bank for that purpose." As to the other purchases, however, the Court said: "There the purchases were made with moneys that cannot be identified as belonging to the bank. The payments were all, so far as now appears, from the general fund then in the possession and under the control of the firm. Some of the money of the bank may have gone into this fund,

but it was not distinguishable from the rest. The mixture of the money of the bank with the money of the firm did not make the bank the owner of the whole. All the bank could in any event claim would be the right to draw out of the general mass of money, so long as it remained money, an amount equal to that which had been wrongfully taken from its own possession and put there. Purchases made and paid for out of the general mass cannot be claimed by the bank, unless it is shown that its own moneys then in the fund were appropriated for that purpose. Nothing of the kind has been attempted here, and it has not even been shown that when the property in this class was purchased the firm had in its possession any of the moneys of the bank that could be reclaimed in specie. To give a cestui que trust the benefit of purchases by his trustee, it must be satisfactorily shown that they were actually made with the trust funds."

There was thus before the court nothing but the bare fact that money had been received and money had been invested. It was impossible to ascertain any of the facts regarding the account which are shown in the present case. "The books of the firm are entirely unreliable. In fact, no general ledger was ever kept, and transactions to enormous amounts can only be traced by memoranda on slips of paper with the help of the explanations of R. T. K. Bain, who was the principal manager. No accounts at all were kept with the bank, and everything, so far as Bain & Bro. were concerned, was found in the greatest confusion." When and in what items the moneys were received from the bank, when and in what items other moneys were received and commingled with the former, whether the mingled account was at any time exhausted, what, if any balance, remained therein at any time, what,

if any, was the lowest balance at any time, when and in what amounts and in what properties investments were made from the mingled fund, whether a low balance was exhausted at any time by an investment, what, if any, part of the trust money remained after an investment for application on a subsequent investment,—none of these things was shown, nor could they be shown; and it was necessary to show them, on any theory of the case. They have been shown in the present case with precision. The question of applying the principle here relied on did not present itself in the Bain case. It was not mentioned; and for the reason that the case lacked the facts upon which alone the question could arise. The point now under discussion was accordingly not involved, and could not be involved. There is, in my opinion, nothing in *Peters v. Bain* which prevents the application of the rule of *In re Oatway* and *Brennan v. Tillinghast*.

As for the Circuit Courts of Appeals, it is said in *Empire State Surety Co. v. Carroll County*, 194 Fed. 593, 605, C. C. A. 8, (1912), that “because the legal presumption is that he regarded the law and neither paid out nor invested in other property the trust fund, but kept it sacred,” “the legal presumption is that promissory notes, bonds, and other property coming to the hands of the receiver were not procured by the use of, and are not, trust property. *Spokane County v. First Nat. Bank*, 68 Fed. 979, 980, 16 C. C. A. 81, 82.” But *Brennan v. Tillinghast* was decided later, on full consideration of the precise point here made; while the earlier case merely assumed, without discussing, the so-called “presumption,” and neglected the all-important feature of that “presumption,” that it relates only to dissipations, and not to retentions in a substituted form. The language of the Circuit Court

of Appeals, 9th Circuit, in *Spokane County v. First Nat. Bank*, 68 Fed. 979, 980 (1895), is subject to the same and additional comment, and despite that language, I am still persuaded that there is no pronouncement in the 9th Circuit which requires the court here to reject the sound rule of *In re Oatway and Brennan v. Tillinghast*.

In the *Spokane County* case, the court, in passing on a demurrer, said: "But while that presumption" (i. e., "that trust funds have not been wrongfully misappropriated") "would prevail as to money on hand, it would not be extended to other assets, for the officers of the bank had as little right to divert the public funds into investment in other property as they had to appropriate them to their own use." This, with every respect, amounts to saying that the bank, because it had no right to invest the public moneys at all, had the right to appropriate the investment of public moneys to its own use. The result is to give the purchased property to the tort-feasor, because he has violated the law. In some way, the commission of a second wrong is supposed to rectify the first. The fallacy which leads to such an intolerable result lies in a misconception of the estoppel. A tort-feasor is not estopped to say that he has preserved the estate; he is estopped to say that he has dissipated it. Now, he may be prohibited by statute from investing it, yet if he does so, for a solvent property, he has preserved it and not dissipated it; and there is no question of estoppel at all. Whether he preserves the trust estate by making a good investment unlawfully, or does so by making it lawfully, is entirely indifferent. If in the latter case he cannot claim it for himself, it is impossible to see why he should have it for himself because in acquiring it he has misapplied the fund. He has already misapplied it in ming-

ling it with his own, and that does not advantage him; why should his additional misapplication in converting it into property cancel the first wrong and restore his advantage? There is, in fact, no presumption against his having done a wrong, either in the first instance or in the second; there is an estoppel, which prevents his profiting by either. The Spokane County case antedates *In re Oatway and Brennan v. Tillinghast*, in which the subject was carefully discussed, and it is plain that none of these considerations was presented in the former case. The court's remark is brief, and occurs in the midst of comments on the sufficiency of a bill. Its expression, above quoted, is not, as it seems to me, to be given the weight of a final pronouncement, binding on the court here.

Indeed, the Circuit Court of Appeals in the 8th Circuit, has somewhat recently held to the contrary of the expression in the Spokane County case. In *Fiman v. State of South Dakota*, 29 Fed. (2d) 776, 781, where a bank acted in violation of a statute in regard to the deposit of public money, it was held that this violation did not exempt the bank from the operation of the estoppel in question. The court said: "We are unable to see why the presumption should not prevail, despite the fact that the bank was acting illegally for a long period of time, or acted illegally in other particulars."

What has been said as to *Peters v. Bain* applies in substance to *Board v. Strawn*, 157 Fed. 49, C. C. A. 6 (1907). The attempt was "to fasten a trust fund upon hundreds of distinct pieces of commercial paper made by many different persons and acquired at different times, because it is probable that some of such bills and notes were ac-

quired with the general funds of the bank with which had been mingled some part of complainants' tax deposits. . . . Complainants have not shown that any single piece of that mass of bills and notes was acquired with the blended moneys of the bank and of the tax fund, still less are they able to show that the assets in the receiver's hands have been actually augmented by a dollar collected from paper so paid for by the mingled fund." In that state of the evidence, of course there could be no identification.

The same remarks may be made about *Schuyler v. Littlefield*, 232 U. S. 707, 58 L. ed. 806. The difficulty was the same as in *Peters v. Bain*; that is, a defect of evidence. In passing on an attempt to trace the trust fund into stock released as collateral from the hands of a bank, the court said: "But the record fails to show when the \$266,600.00 was deposited, and it also fails to show with the requisite certainty the particular use made by Brown & Company of that money."

Indeed, in the cases which may be thought to question the right to attribute investments to the trust, it will be found uniformly, I believe, that the attempt is to impress a trust without a showing beyond the fact of the mingled fund and the fact of the investment. In the present case, the intervenor has supplied the additional facts necessary to relate a specific low balance, containing the trust money, to a specific investment.

I am convinced that there is nothing in the doctrine of the *Hallett* case to prevent the attributing of the investment to the trust fund, and the subsequent dissipation of money to the tort-feasor's own funds; and on the contrary, that it is required.

(b) It is urged that if this be true at all, it is only so in the case of a voluntary trust. The argument is that in a trust ex maleficio, such as the present, it is absurd to presume that the person whose faithlessness has made him a trustee must intend faithfully to preserve the money for the person he has defrauded, and that it is rather to be presumed that he will continue faithless and effectively finish in his own interest what he began in that interest.

Here again is a misconception of the doctrine of the Hallett case. The rule which refuses, in the absence of earmarking, to allow the trustee to say that he has dissipated his cestui's money rather than his own, is not truly based on a presumption of his intention, and it is not really concerned with his intention at all, imaginary or otherwise; it is a rule of substantive law, founded upon an equitable estoppel. The remarks already made on this subject are, I think, a sufficient answer to the present contention.

When the voluntary trustee, in acquiring property, out of the mixed fund, is held to have retained the same fund, including the trust money, in a new form, and with the same benefit to the cestui, it is not because of any supposed desire of the trustee to remain honest, but because the fund remains the same, and because the trust money, once in it, remains in it, whatever the form. The involuntary trustee is in the same situation. However wrongfully he may have acquired the money, and however dishonest his actual intention throughout, the mixed fund, if it includes the trust money, continues to do so in any supposable form, not because he intends it, nor even despite his contrary desire, but because it is the same thing, unchanged in substance.

This point of view assumes that the mixed fund, at the time of investment, contains the trust money; and it is only in reference to the propriety of that assumption that the doctrine of the Hallett case has any pertinence; for once admit that the mixed fund contains the trust money, there is nothing to consider but the fact of the latter's continuance in the fund, unchanged but in form. If the estoppel in question obtains in the case of an involuntary trustee, the mixed fund does necessarily contain the trust money, within the limit of the lowest balance. There can be no doubt of this in the case of a voluntary trustee. That an involuntary trustee is subject to the same estoppel is clear from a correct understanding of the reason and object of the estoppel, and is apparent from those decisions which disclose such an understanding. Counsel have said that the federal courts are silent on this question, but it appears that they have announced views according with the above.

In *Central Nat. Bank v. Conn. Mut. Life Ins. Co.*, 104 U. S., 14 Otto 54, 26 L. ed. 693, 700, the Supreme Court analyzed the holding of the Hallett case, and among other things said that that case held "that there is no distinction between an express trustee and an agent or bailee or collector of rents or anybody else in a fiduciary position." The principles of the Hallett case are approved by the Supreme Court and its approval attaches to the doctrine just quoted. It is true that mention is not specifically made of a trust arising out of fraud, but the doctrine approved extends, as stated, to "anybody in a fiduciary position," and certainly the trustee *ex maleficio* is in that position.

In *Smith v. Mottley*, 150 Fed. 266, 268, C. C. A. 6 (1906), the court said: "The question which we have

before us comes then to this: Did the petitioner, in the circumstances stated, have a lien upon the assets of the bank for her money, which by the wrongful conduct of the bank was incorporated in them?

"We think that upon the authority of our own decisions, and especially that of *Smith, Trustee, v. Township of Au Gres* (decided at our session in November last) 150 Fed. 257, this question should be answered in the affirmative. The question as there presented was raised in the same way and upon substantially identical facts. In that case the property of the township had been confided to the bankrupt, and he had committed a breach of trust in converting it to his own use and mingling it with his stock of goods, while here the possession of the property was wrongfully taken in the first instance. But it makes no difference in the application of the principle of that decision that in one instance the wrongdoer was lawfully in the possession of the property and in the other not. The critical fact is in the wrongful appropriation by one party of the property of another by mingling it indistinguishably with his own, and it is not ordinarily important by what means he became possessed of the property.

"Other cases in which we have recognized and applied the doctrine of the case just cited are *City Bank v. Blackmore*, 75 Fed. 771, 21 C. C. A. 514, *In re Taft*, 133 Fed. 511, 66 C. C. A. 385; *Holder v. Western German Bank*, 136 Fed. 90, 68 C. C. A. 554, and *Erie R. Co. v. Dial*, 140 Fed. 689, 72 C. C. A. 183. Upon the same facts as in the case of *Holder v. Western German Bank*, the Circuit Court of Appeals for the Fifth Circuit applied the same principle in reaching a like result. *Western German Bank v. Norvell*, 134 Fed. 724, 69 C. C. A. 330."

In *Richardson v. New Orleans Deb. Red. Co.*, 102 Fed. 780, C. C. A. 5 (1900), a bank obtained money by fraud. The court said: "Now, if the banker, having money in his bank, fraudulently receives other money and mingles it with the moneys on hand, can the defrauded depositor claim his money? That is the question presented by this case." The court held that a trust arose by reason of the fraud and we accordingly have a case of a trustee *ex maleficio* as in the present instance. The *Hallett* case was reviewed and its doctrine was declared applicable to an involuntary trustee. The court said: "If an agent, bailee, or trustee invests another's money in personal property, a trust results. If one's money is lent, and a note or bond taken, the owner of the money can have a lien or trust declared on the note or bond to secure his money so used. Numerous cases show that money can be traced into other assets, notes, bonds, and stocks. There is no good reason for not applying the same doctrine to money, the measure and representative of all property. If one's money is used with other money in buying a bond, equity can fasten a lien on the bond, and sell it to reimburse the one whose money has been so used. So, we think, if one's money is wrongfully mingled with a mass of money, that equity can direct the possessor and wrongdoer, or his successor, to take out of the mass a sum sufficient to make restitution." (Underscoring mine)

In *Fiman v. State of So. Dakota*, 29 Fed. (2d), 776, 781, C. C. A. 8, a case of a wrong-doing bank violating a statute in regard to the deposit of public moneys, the court said: "We are unable to see why the presumption should not prevail, despite the fact that the bank was act-

ing illegally for a long period of time or acted illegally in other particulars.”

In *First National Bank v. Fidelity & Deposit Co.*, 48 Fed. (2d) 585, C. C. A. 9, the court held that the bank was a trustee *ex maleficio*, because it received public moneys on deposit from a county treasurer in excess of the amount authorized by the Board of County Commissioners. The court held: “The act of the bank in receiving them was therefore clearly wrongful and in violation of law.” The court held that the county had a good claim against the bank’s receiver for the smallest amount of cash and cash items in the bank between the time of unlawful deposits and the close of the bank.

The federal courts have accordingly repudiated any supposed distinction between trusts arising by agreement and trusts arising by fraud. The views of an independent commentator to the same effect are found in the note in 82 A. L. R., as follows: “The argument that the logical basis of the presumption is absent where the trust comes into existence by virtue of the wrongful act of the (trustee) has much plausibility as a mere dialectical exercise; but the law is designed for the practical administration of justice, rather than as a vehicle for the development of logical subtleties. Logic is not an end in itself, but a means to an end; the true end of the law is justice. The relation of logic to the law is as a tool, rather than as a tyrant; otherwise it would be the death of the law, and not its life. The fiction in question was invented for the benefit of the *cestui que trust* in cases where his trust money is commingled with the funds of the trustee, and it should not be followed to its logical conclusion where to do so would defeat recovery in a case no less meritorious than those in which it

is employed in aid of a recovery. There should be consistency in results rather than merely in the steps employed in reaching a result.

“With regard to the presumption in question, it is stated by Professor Austin W. Scott, in 27 Harvard L. Rev. 125, 129: ‘ . . . The claimant ought . . . to have an interest in what is left, not because of any intent of the wrongdoer, but because the wrongdoer, whatever his intent, should not be allowed, by taking away a part of the fund, to deprive the claimant of his lien on, or share of, the rest of the fund.’ ” (P. 160).

Some of the state courts, including the Supreme Court of California, have refused to apply the doctrine of the Hallett case to an involuntary trustee. This supposed distinction is enforced in *People v. California Safe Dep. & Tr. Co.*, 175 Cal. 756, in which it is said that “Whatever name be given to it, the rule originates in and rests upon the underlying presumption ‘that a person is innocent of crime or wrong.’ ” With all proper respect, it does not so originate. It originates in and rests upon an underlying estoppel whereby a wrongdoer is prevented from arrogating to himself the benefit of his own wrong. This decision, like others, is, in my opinion, based upon a misconception of the rule as a mere presumption or fiction contingent upon an imagined intention of the trustee. This misconception has led to an exceedingly unjust gift to the guilty and penalty to the innocent. The considerations which have been heretofore mentioned were not discussed by the California court, its attention being directed exclusively to a literal and verbal construction of a so-called presumption of intent. On reason the views expressed in the California case should, in my opinion, not be followed. This court is not bound thereby and the

federal courts, as above seen, have, upon sound grounds, reached an opposite conclusion, which, I think, should be here recognized as authority.

It is my opinion that a trustee *ex maleficio* is, like any other, estopped to attribute his dissipations first to the trust fund.

(c) It is contended that the case cannot be decided on a doctrine of estoppel or a presumption, but that there must be a clear showing, by direct evidence, of an actual and intended appropriation of the invested money to the purposes of the trust; and that this must be so, at least, on receivership, where the equities of general creditors intervene.

It is thought that *Peters v. Bain*, 33 L. ed. 696, supports the generalisation first mentioned. I have already discussed this case, and, as previously said, it decides no more than that proof merely of the mixed fund and of purchases thereout is insufficient. On such proof, it was insisted that the receiver of the defrauded bank was "entitled to a charge upon the entire mass of the estate." (P. 704) The only specific evidence offered was that in one case property was received from a debtor in payment of his note made to the defrauded bank, which Bain & Bro. had rediscounted. This of course, as held, was not proof that Bain & Bro. "were purchasing property with the money of the bank." (P. 705). The evidence necessary for bringing into play the principles now in question was not and could not be produced, due to the utter confusion of the accounts. Nothing is said to indicate that the proof would have been insufficient if it had been produced. The court said that the difficulty was the same as that expressed in *Frelinghuysen v. Nugent*,

36 Fed. 229, 239, "that it does not appear that the goods claimed . . . were either in whole or in part the proceeds of any money unlawfully abstracted from the bank." (P. 704). All that this amounts to is that there must be evidence of some kind; but whether it must be of one kind and not another the court does not say, and is not called on to say. The case, and all the other cases which simply declare the necessity of proof, leave open the method by which the proof may be adduced; and the cases which deal specifically with the Hallett estoppel as a method of proof uniformly approve it. Thus, *Schuyler v. Littlefield*, 232 U. S. 707, 58 L. ed. 806, approving a particular feature of the rule in Hallett's case, merely holds that "the record fails to show when the (money) was deposited, and it also fails to show with the requisite certainty the particular use made by Brown & Company of that money." Here, as in the other cases on this subject, it is a matter of the absence of proof; both of the kind presented in the case now at bar, and of any other.

Up to the time of the investment in property, the estoppel in question, as is well settled, operates as an effective means of tracing the trust money into the mingled fund. The investment does no more than change the form of the fund. It is hard to perceive why this mere change of form should abolish the evidence of the pre-existing condition, which was perfectly competent to prove it. That evidence being properly received, the effect of it remains, whether the subject affected be money or bonds, or both.

The requirement suggested would in most cases of fraud, if not all, demand the impossible. It would compel the **earmarking** of the invested money, in a case which by

its terms presupposes a mingling. How this could be shown, does not appear. Obviously, the faithless fiduciary will not expressly set apart one portion for investment for the trust and another for investment for himself. If he must make such an express appropriation, there can hardly be a case of recovery, unless the money remains as money. In the latter case, there is no such requirement of express appropriation or earmarking; the whole mass remains subject to the trust. Why should there be, when the mass includes, by substitution, bonds or stock? The principles which govern the fiduciary's accountability do not fluctuate with the form.

“Proof that a trustee mingled trust funds with his own and made payments out of the common fund is a sufficient identification of the remainder of that fund coming to the hands of the receiver, not exceeding the smallest amount the fund contained subsequent to the commingling. . . .” *Empire State Surety Co. v. Carroll County*, 194 Fed. 593; also, *Fiman v. State of So. Dakota*, 29 Fed. (2d) 776, 779, C. C. 8, and federal cases there cited, hereinbefore referred to. Such proof being sufficient as to “the remainder of the fund,” it is sufficient as to the intervening status of the fund at the time of any change in the form thereof.

The character of proof is not changed by receivership. The receiver gets nothing more than his principal had; and he takes subject to all the equities. The marshalling of claims against the estate does not put into the estate what was not there.

In a case in which a State sought to pursue its bank deposits as a trust fund in the hands of the bank's receiver, and in which the court held the beneficiary entitled

to the estoppels and so-called "presumptions" hereinbefore discussed, the court said: "The receiver stands in the place of the bank, taking the assets in trust for the creditors, subject to the claims and defenses that might have been interposed against the insolvent corporation. *Skud v. Tillinghast* (C. C. A.) 195 Fed. 1, 5; *Scott v. Armstrong*, 146 U. S. 499, 13 S. Ct. 148, 36 L. ed. 1059." And lest it be thought that this applied only to the unchanged remainder of a cash fund in the hands of the fiduciary, it should be particularly noted that the court permitted the fund to be followed into its changed form, to-wit, into the fiduciary's deposits with correspondent banks, and this under the cited authority of *Brennan v. Tillinghast*, 201 Fed. 609. The case seems to be definitely in point: *Fiman v. State of So. Dakota*, 29 Fed. (2d) 776, 781, C. C. A. 8.

Practically all of the federal cases involving the method of proof here in question are receivership and bankruptcy cases, and it would be useless to cite them. Those which have previously been cited are of that class. Nowhere does it appear that receivership or bankruptcy makes any difference in principle or method.

My opinion is that in this receivership proceeding, as in a proceeding against the fiduciary himself, and in an attempt to follow the trust money into property bought out of the common fund, as in an attempt to follow it into a common money fund, the facts shown, with the consequent estoppels, constitute a sufficient tracing and identification.

(d) It is urged that in any event the purchase must be made at the moment of the lowest balance, before any **accretion** thereto of moneys belonging to the fiduciary, and

before any disbursement otherwise from the common fund. This is for the reason that subsequent transactions with the account may as well be attributed to the previous low balance as to the new money, and moneys then invested in property may represent a residue of owned money and not trust money. This has already been answered, if my views upon the main questions are sound. No matter when the investment is made, the lowest amount meanwhile in the account has always been there, and is there at the moment of investment; because at no time will the fiduciary be allowed to say that he has dissipated the trust money rather than his own. If this principle is well established, as it must be held to be, it cannot matter when the low balance occurs, so it be between the deposit of trust money and the investment; for the fiduciary has at all times spent his own money and preserved the trust money. I do not think there is any merit in the contention.

-IV-

INTEREST

In my opinion, no interest should be allowed.

It is very well settled that where trust money in the hands of a receiver is earmarked, or is identified by its inclusion in a common fund, within the limit of the lowest intervening balance, no interest is allowable, either before or after receivership. *First Nat. Bank v. Fidelity & Dep. Co.*, 48 Fed. (2d) 585, C. C. A. 9; *Poisson v. Williams*, 15 Fed. (2d) 582, D. C., E. D. N. Car.; *Smith Reduction Corp. v. Williams*, 15 Fed. (2d) 874, D. C. E. D. N. Car.; *Butler v. Western German Bank*, 159 Fed. 116, C. C. A. 5; *Hallett v. Fish*, 123 Fed. 201, C. C., D. Ver-

mont; *Richardson v. Louisville Banking Co.*, 94 Fed. 442, C. C. A. 5; *Merchants' Nat. Bank v. School District*, 94 Fed. 705, C. C. A. 9; *Elizalde v. Elizalde*, 137 Cal. 634, 638. Two of these cases, as observed, are from the 9th Circuit.

None of the above authorities is concerned with a case of investment of the trust money, and no authority of that precise application has been found. But the reasons which lead to the cited decisions would seem to apply as well, whether the ultimate form of the fund be money or property or both. In any case, the beneficiary receives back his own, and is entitled to no more, whether by way of interest as damages or otherwise. It is true that *Richfield* acknowledged an obligation to pay interest; but the right here is not based on agreement, but on an obligation arising by operation of law; in fact, the recognition of a binding agreement would be fatal to *Universal's* right as a defrauded cestui. If \$1000.00 of trust money is traced into a property which cost that much and no more, the property belongs wholly to the cestui; he gets the property, and nothing more. If \$1000.00 of trust money is traced into a property which cost \$2000.00, he gets the property likewise, to the extent of \$1000.00; and his property interest, by the same logic, is not increased by interest. Otherwise, where \$1000.00 of trust money is traced into a common fund of \$2000.00 in money, he would be entitled to interest; but the cases above cited hold otherwise. Here, as elsewhere, his rights do not fluctuate with the form.

-V-

COUNTER CLAIM OF RECEIVER FOR
PAYMENTS ON PROPERTIES

The receiver claims a lien, prior to Universal, for payments made by him on the purchase price of certain properties in question. This is on the ground that the payments preserved the title for Universal's benefit. No authorities are cited for the point, and the authorities cited against it are not very helpful. *Hanover Nat. Bank v. Suddath*, 215 U. S. 122, 54 L. ed. 120; *Cook Co. Nat. Bank v. Burley*, 107 U. S. 445, 27 L. ed. 537; *Topas v. John MacGregor Grant, Inc.*, 18 Fed. (2d) 724, C. C. A. 2; *Poisson v. Williams*, 15 Fed. (2d) 582, D. C., E. D. N. Car.; *Am. Brake Shoe & Foundry Co.*, 10 Fed. (2d) 920, C. C. A. 2. These are to the effect that a trustee cannot set off against his trust obligation an obligation owing to him individually by the beneficiary. This is not quite the situation here, but other considerations are, I think, fatal to the claim. The payments were merely on account of the purchase price, and they stand in the same position as payments on the purchase price made by Richfield itself. If Richfield paid \$1000.00 for a piece of property, of which \$500.00 was its own money and \$500.00 was Universal's, obviously Universal's right would be first; otherwise everything heretofore said would be meaningless. The receiver is in no better position. If his payments preserve the title, they do so for Richfield; and the merely incidental benefit to Universal does not reverse the primary fact. Moreover, if the benefit to Universal is to be considered, it was the duty of Richfield and its receiver to preserve to Universal the title which Richfield had undertaken to procure for it. Richfield and its

estate would no doubt have been liable to Universal for the loss of the latter's title, having intermingled that title with its own and having itself caused the former to depend on the latter. In addition, Universal's right was prior in time, and the payments were made with implied, if not actual, notice of that right. Payments made subsequently by Richfield itself would certainly be subject to the known existing right of Universal; and the receiver's payments are in the same inferior position.

No lien should be allowed to the receiver for his payments.

-VI-

STATUS OF THE BOND TRUSTEE

The trustee has not claimed any priority, but counsel for Universal have discussed the possible point, and it should perhaps be noticed. All of the payments in question out of trust funds were made after the date of the trust indenture. The interests acquired by those payments could only be regarded as included in the indenture by virtue of a clause thereof extending the lien to after-acquired interests, assuming the existence of such a clause. It is true that a bona fide purchaser or encumbrancer, for value, without notice, will be protected. *Peters v. Bain*, 133 U. S. 670, 33 L. ed. 696; *Omaha Nat. Bank v. Fed. Res. Bank*, 26 Fed. (2d) 884, 887, C. C. A. 8; *Jones v. Missouri Edison Electric Co.*, 144 Fed. 765, 780, C. C. A. 8; *Spokane County v. First Nat. Bank*, 68 Fed. 979, 980, C. C. A. 9; *Ervin v. Oregon Ry. & Nav. Co.*, 27 Fed. 625, 635, C. C., E. D. N. Y. But it appears to be established that an encumbrancer does not occupy that position in reference to after-acquired

property, that his lien attaches in that case only to what the debtor actually acquires, and that if the latter gets nothing in fact, regardless of appearances, the former gets nothing. *Holt v. Henley*, 232 U. S. 637, 58 L. ed. 767; *Detroit Steel Cooperage Co. v. Sistersville Brewing Co.*, 232 U. S. 712, 58 L. ed. 1166; *Fosdick v. Schall*, 99 U. S. 235, 25 L. ed. 339.

The lien of the trust indenture is subject to the trust interest of Universal.

-VII-

RECOMMENDATION

I recommend that a trust be declared and enforced in favor of Universal in the following amounts severally, without interest, upon such right, title, and interest as may appear to be vested in Richfield and its receiver, and superior to any right, title, interest, or lien of the trustee under the bond indenture, in and to the following properties severally, as identified at page 41, *supra*, and described in Receiver's Exhibit F:

<u>Parcel 1:</u>	"Franklin & Vermont Service Station," real property, described at page 1 of said Exhibit	\$ 492.60
<u>Parcel 2:</u>	"Delaney Producing Property," leaseholds, described at pp. 28 et seq. of said Exhibit	103,442.33
<u>Parcels 3 and 4:</u>	Ten storage tanks, personal property, described at pp. 2 and 3 of said Exhibit	91,881.83

<u>Parcel 5:</u> "Mull Property," real property, described at p. 19 of said Exhibit	500.00
<u>Parcel 6:</u> "Vapor Recovery Plant," personal property, described at p. 25 of said Exhibit	34,332.84
<u>Parcel 7:</u> 106,000 shares of Universal stock, certs. LX:26, 27, 28, and 32	162,719.30
<u>Parcel 8:</u> 5,100 shares of Universal stock, cert. LX31	10,625.00
	<hr/>
	\$403,993.92
	<hr/>

For the enforcement of said trusts, respectively, I recommend that upon any sale in this action, the aforesaid parcels be offered for sale and sold separately from each other and from all other property, and that Universal be allowed a first charge upon the gross proceeds of the sale of each of said parcels, in the amount above specified in respect thereof, the expense of each sale to be a charge upon any surplus realized from such sale over the amount receivable as aforesaid by Universal, and in defect of such surplus, upon the receivership estate held under the order of appointment of January 15, 1931, as an expense of administration. I recommend that jurisdiction be retained for the purpose of awarding such other relief as may appear to be equitable, for the enforcement of said trust, in case there shall be a failure to effect a sale in the case of any parcel or parcels.

As to Parcels 3 and 4, and Parcel 6, there is no evidence as to whether, or to what extent, they are attached to the land, or whether, or to what extent they are removable. There is no presumption that they are irremovably affixed to the realty in such manner as to be a part thereof. They are therefore treated as removable personal property, and the trust attaches to them as such. Even if there were difficulty in detaching or removing them, due to their being affixed in some degree (and of this there is no evidence), the application of the trust to them as personal property would not be affected. *Holt v. Hanley*, 232 U. S. 637, 58 L. ed. 767; *Detroit Steel Cooperage Co. v. Sistersville Brewing Co.*, 232 U. S. 712, 58 L. ed. 1166.

There are filed herewith, as part of this report (a) Reporter's Transcript of the Proceedings and Evidence, (b) Exhibits, and (c) Briefs. I certify that the Reporter's Transcript and the Exhibits filed herewith contain all the proceedings and evidence upon which this report is made.

Respectfully submitted,

WILLIAM A. BOWEN
SPECIAL MASTER"

EXCEPTIONS TO REPORTS OF THE
SPECIAL MASTER.

Timely exceptions to the reports of the Special Master were filed with the Clerk of the United States District Court by Security First National Bank of Los Angeles as trustee, which exceptions read as follows:

“In the District Court of the United States, for the
Southern District of California,
Central Division.

-o0o-

Security-First National Bank of)	
Los Angeles, a national banking)	
association, as trustee,)	
)	
Plaintiff,)	
)	
vs.)	
)	
Richfield Oil Company of Cali-)	
ifornia, a corporation, and William)	In Equity
C. McDuffie, as Receiver of Rich-)	Consolidated Cause
field Oil Company of California,)	No. S-125'J.
a corporation,)	
)	EXCEPTIONS
Defendants.)	OF PLAINTIFF
)	SECURITY-
Universal Consolidated Oil Com-)	FIRST
pany, a California corporation,)	NATIONAL
)	BANK OF LOS
Intervenor.)	ANGELES, A
_____)	NATIONAL

The Republic Supply Company of)	BANKING
California, a corporation,)	ASSOCIATION,
)	TO MASTER'S
Complainant,)	REPORT.
)	
vs.)	
)	
Richfield Oil Company of Cali-)	
fornia, a corporation,)	
)	
Defendant.)	
_____)	

Now comes SECURITY-FIRST NATIONAL BANK OF LOS ANGELES, a national banking association, plaintiff in the above entitled cause, and excepts to the report of the Honorable William A. Bowen, Special Master herein, filed in the office of the clerk of this court on the 26th day of May, 1933, in the following particulars, to-wit:

1. To the finding of fact and/or conclusion of law (Report p. 82, line 26) that the lien of the bond or trust indenture sought to be foreclosed herein is subject to the trust interest of intervenor, Universal Consolidated Oil Company, a corporation, as found and declared by said Special Master as to the parcels of property specified in said report.

2. To the finding of fact and/or conclusion of law (Report p. 76, line 24) that said intervenor has sufficiently

identified and traced its funds into the various parcels specified in the report of said Special Master and hereinafter specified, either in the amounts set forth or otherwise.

3. To the finding of fact and/or conclusion of law (Report p. 57, line 13) that the various parcels specified in said report and hereinafter specified either in toto or to the respective amounts or to the extent of the trust imposed upon them in favor of said intervenor constitute the property of intervenor in a substituted form.

4. To the conclusion of law (Report p. 83, line 4) that said intervenor is entitled to have a trust imposed upon the various parcels specified in said report and hereinafter specified either in the amounts specified therein or in any amounts whatever.

5. To the conclusion of law (Report p. 76, line 24) that the evidence herein constitutes a sufficient tracing and identification of the funds of said intervenor to warrant the imposition of a trust in favor of said intervenor upon the various parcels specified in said report and hereinafter specified either in the amounts set forth therein, or in any amounts whatever.

6. To the conclusion of law (Report p. 67-a, line 6) that the investments revealed by the evidence (to wit, the purchases by defendant Richfield Oil Company of California, a corporation, of the parcels specified in said report and hereinafter specified) should be attributed either in whole or in part to the trust funds of intervenor then

and there in the possession of said defendant and commingled with private funds belonging to said defendant.

7. To the conclusion of law (Report p. 67-a, line 6) that in the case of purchases of real or personal property made by a trustee out of a fund in which trust and private funds had theretofore been commingled, the trust moneys may be traced into such properties wholly through the application of presumptions and wholly without evidence of any actual devotion of such trust funds or any part thereof as distinguished from the commingled funds to the respective purchases in question.

8. To the failure of said Special Master to conclude that the evidence was insufficient to support a finding that intervenor had actually traced into the parcels specified in said report and hereinafter specified any of the trust funds of intervenor formerly in the possession of defendant Richfield Oil Company of California, a corporation, as distinguished from the commingled fund in which said trust funds and the private funds of said defendant were blended.

9. To the failure of said Special Master to conclude and to declare that mere proof of purchases out of a fund in which trust and private moneys have been commingled is wholly insufficient to warrant the imposition of a trust upon the property so purchased.

10. To the recommendations, and each of them, of said Special Master as embodied in his said report (p. 83, line 4), to wit:

(a) That a trust be declared and enforced in favor of Universal Consolidated Oil Company, a corporation, in the amounts specified below and upon such right, title and interest as may appear to be vested in Richfield Oil Company of California, a corporation, and its receiver, and superior to any right, title, interest or lien of this plaintiff under the bond or trust indenture sought to be foreclosed herein in and to the following properties and parcels described in said report, to-wit:

Parcel 1.	“Franklin & Vermont Service Station”, real property.	\$ 492.60
Parcel 2:	“Delaney Producing Property”, leaseholds.	103,442.33
Parcels 3 and 4:	Ten storage tanks, personal property.	91,881.85
Parcel 5:	“Mull Property” real property.	500.00
Parcel 6:	“Vapor Recovery Plant”, personal property.	34,332.84
Parcel 7:	106,000 shares of Universal Stock, Certs. LX:26, 27, 28 and 32	162,719.30
Parcel 8:	5,100 shares of Universal stock. cert. LX 31	10,625.00
		<hr/> \$403,993.92

(b) That upon any sale to be had in this action the aforesaid parcels be offered for sale and sold separately from each other and from all other property, and that Universal Consolidated Oil Company be allowed a first charge upon the gross proceeds of the sale of each of said parcels in the amount above specified in respect thereof, the amount of each sale to be a charge upon any surplus realized from such sale over the amount receivable as aforesaid by said Universal Consolidated Oil Company, a corporation; and

(c) That jurisdiction be retained for the purpose of awarding such other relief as may appear to be equitable for the enforcement of said trust in the event there shall be a failure to effect a sale in the case of any parcel or parcels.

DATED this 15th day of June, 1933.

O'MELVENY, TULLER & MYERS
and Pierce Works
and Clinton La Tourette

Solicitors for Plaintiff, Security-First National Bank of
Los Angeles, a national banking association."

Timely exceptions to the reports of the Special Master were filed with the Clerk of the United States District Court by Universal Consolidated Oil Company, which exceptions read as follows:

“In the District Court of the United States
Southern District of California
Central Division

The Republic Supply Company of ()
California, a corporation, ()

Complainant, ()

-vs- ()

Richfield Oil Company of Cali- ()
fornia, a corporation, ()

Defendant. ()

Security-First National Bank of ()
Los Angeles, a national banking ()
association, as trustee, ()

Plaintiff, ()

-vs- ()

Richfield Oil Company of Cali- ()
fornia, a corporation, and William ()
C. McDuffie, as Receiver of Rich- ()
field Oil Company of California, ()
a corporation, ()

Defendants. ()

Universal Consolidated Oil Com ()
pany, a California corporation, ()

Intervenor. ()

IN EQUITY
CONSOLIDATED
CAUSE
NO. S-125-J

EXCEPTIONS TO
REPORT OF SPECIAL MASTER

Now comes the UNIVERSAL CONSOLIDATED OIL COMPANY, the Intervenor in the above entitled cause, and excepts to the report of Honorable William A. Bowen, Special Master herein, filed in the office of the Clerk of this Court on the 26th day of May, 1933, in the following particulars to-wit:

AS TO FINDINGS OF FACT

1. To the finding of fact on page 33, lines 3 to 7, inclusive, of the Special Master's Report, reading as follows:

"It is my opinion that the balance which is properly to be used in applying the intervenor's theory here is the third of those above described; that is, that which is shown by deducting all withdrawals posted during the day from the opening balance, without crediting deposits for the day."

2. To the finding of fact on page 33, lines 8 to 14, inclusive, of the Special Master's Report, reading as follows:

"The second above described, which results from periodical postings during the day of deposits and withdrawals, after crediting the opening balance, is not properly usable, for the reason that under the bank's practice, as above detailed, such balance disregards the actual order of deposits and withdrawals in point of time, and conse-

quently does not reflect the true state of the account at any time.”

3. To so much of the findings of fact in the Special Master’s Report, line 15, page 33, to line 14, page 34, as reads:

“The first above described, the so-called closing balance, is not usable, for the reason that by its nature it necessarily disregards the actual order of deposits and withdrawals in point of time, and consequently does not reflect the true state of the account at any time since the previous closing balance. To take it as an accurate reflection, it must be assumed that at the moment of each withdrawal deposits had been received in an amount sufficient to leave a balance at least equal to that resulting from the whole day’s transactions. Unless such an assumption is imperative there is an equal likelihood that at any moment of the day the deposits previously received and the withdrawals then made may have produced a balance less than that resulting from the whole day’s transactions down to zero. Admittedly the intervenor is not entitled to the benefit of a replenishment of the account after its reduction or exhaustion, yet the closing balance would necessarily yield that benefit if during the day the account had been reduced or exhausted. Under the burden of proof which is on the intervenor, it can not avail itself of the assumption which is implicit in the closing balance in

default of that direct evidence which might have been provided by the striking of time-regarding balances during the day. The failure of the bank to strike balances of that conclusive character might perhaps in another situation afford some reason for looking to the closing balances as the best evidence of which the case admits in view of banking custom; but in the present situation the intervenor in tracing a trust fund into and out of a common account is bound to better proof than that indicated, and finds it at hand in the facts which support the third description of balances. The other two being inadmissible, the intervenor must content itself with the third, else it must be without any proof at all."

4. To so much of the findings of fact appearing on page 37 of the Master's Report, lines 8 to 11, as reads:

"This disposes of any conception of the closing balance as usable for the intervenor's purpose. It disposes of any contention that the order of time may be disregarded in an inquiry of this sort."

5. To so much of the findings of fact as set forth in line 16, page 37, of the Master's Report, down to and including line 3, page 38, thereof, as reads:

"The result of the foregoing is that the claim must fail unless there is a minimum situation upon which the intervenor may rely; that is, a situation which assumes

an order of deposits and withdrawals which at the worst must have occurred. Such a situation presents itself in a case where no deposits are made during the day in question, until all withdrawals of that day have been effected. In that case the order of withdrawals is indifferent, as they all precede the deposits. Now, it is a fact that withdrawals and deposits occurred each day, and that there was always an opening balance; whence some sort of balance, on one side or the other, continually resulted. This balance cannot be disregarded altogether, if there is a way of regarding it without detriment to defendants' position, correctly maintained as above stated. This position, that the time order must be observed, is preserved, and the proven existence of balances of some sort is recognized, by treating the deposits of the day as coming in after the withdrawals. * * * The intervenor is entitled to no more, and the defendants must concede so much."

6. To the findings of fact set forth in line 1, page 39 of the Special Master's Report, to line 16, inclusive, page 40 of the Special Master's Report, wherein and whereby the lien of the intervenor is limited upon the properties therein described, by a calculation based upon the low balances of the Richfield Oil Company in its account with the Security-First National Bank of Los Angeles, resulting from the deduction of withdrawals for the day from the opening balance without crediting deposits for the day.

7. To so much of the findings of fact as appear in lines 25 to 32, inclusive, of page 40 of the Special Master's Report, wherein it is found that the amount of the trust funds traced into the items of property described as Parcels 1 to 8, inclusive, as set forth therein, did not exceed the amount set after the various parcels of property, or exceed the total sum of \$403,933.92.

8. To the failure of the Master to find that the proper method to be employed in ascertaining low bank balances of the defendant Richfield Oil Company in this case, is to take the closing balance of the Richfield Oil Company in the Security-First National Bank of Los Angeles, after crediting on the books of the bank the opening balance and all deposits for the day, and charging on the books all withdrawals for the day.

8a. To the finding of fact as set forth in line 1, page 39, to line 16, inclusive, page 40, of the Special Master's report, wherein and whereby the Special Master found that the low balance in the bank account of the Richfield Oil Company with the Security-First National Bank on the dates set forth therein was the opening balance in said account on each of said days mentioned less all checks drawn against said account during the same day, and without giving any credits for the deposits made in the said account during the same day. The evidence

shows that the only balance recognized by the bank as controlling with respect to said account was the closing balance at the end of each day after giving credit for all deposits made during the day and deducting all withdrawals made during the same day. That the bank treated each day's transactions as an entirety, and without making any attempt to enter checks drawn or moneys deposited in their order of presentation, and that the only balance recognized by the bank as controlling is the balance struck at the end of each day.

9. To the failure of the Master to find that the takings of Universal Consolidated Oil Company's funds by Richfield Oil Company, and the assets purchased by Richfield Oil Company with the commingled funds, and the low bank balances in Richfield's account with the Security-First National Bank of Los Angeles under each of the three theories hereinbefore described, and the amount of trust funds traceable into each asset purchased by Richfield and claimed under each theory, is in accordance with the following tabulation:

BY REFINERY GROUP PRODUCING PROPERTIES
 LOW BALANCES UNDER THREE THEORIES ADVANCED AND AMOUNT
 TRACEABLE INTO EACH ASSET CLAIMED UNDER EACH THEORY

(1)	(2)	(3)	(4)	(5)	(6)	(7)	(8)	(9)
Date	Deposit of Universal Money in Richfield Account	Amount Paid on Property for from Commingled Fund	Lowest Daily Closing Balances Between Takings of Universal Funds	Liens Claimed for the Following Sums by Reason of Column 4	Lowest Posted Balances Shown on Bank's Books During Any Day Between Takings of Universal Funds	Liens Claimed for the Following Sums By Reason of Column 6	Lowest Balance Ascertained by Deducting All Checks Cleared Each Day Without Crediting Deposits made During the Same Day	Liens Claimed for the Following Sums by Reason of Column 8
1929								
Nov 13	\$750 000.00		\$272 704.61		\$209 198.80		\$93 635.65	
" 19					198 719.90			Delaney group producing properties
" 27		\$50 000.00		\$50 000.00		\$50 000.00		
" 29		44 540.00		44 540.00		44 540.00		
" 30								43 635.65
" 30		500.00		500.00		500.00		Rioco refining storage tanks, Hynes, Calif.
" 30		35 421.75		35 421.75		35 421.75		Service station at Franklin and Vermont, Los Angeles
Dec 9		164 746.20		142 242.86		68 258.15		Steel tanker Eskoskee
" 23		168 663.06						Steel tanker Larry Doheny
" 23		190 914.94						Steel tanker Pat Doheny
" 23							76 032.84 (red)	Richmond marine terminal, Contra Costa County, Calif.
" 24								Rioco refinery storage tanks, Hynes, Calif.
" 31		49 385.00						Service station at Franklin and Vermont, Los Angeles
1930		500.00						Delaney group producing properties
Jan 3		50 000.00						Delaney group producing properties
" 3		15 825.00						Richville camp site, Backus property, Long Beach, Calif.
" 11								
" 20	200 000.00		466 764.36		466 764.36		336 646.20	
" 23						500.00	308 662.67	
" 24		500.00		500.00		500.00		500.00
" 27		221 202.08		199 500.00		199 500.00		199 500.00
" 29		50 000.00						Land, Sacramento distributing plant, Sacramento, Calif.
" 30		53 680.00						106,000 shares capital stock Universal Consolidated Oil Company, certificates LX 26, 27, 28, 52
" 30		500.00						Delaney group producing properties
Feb 1		464 148.47		462 088.47				Rioco refinery storage tanks, Hynes, Calif.
" 15	500 000.00	(red)	447 704.86	443 916.47			222 642.41 (red)	Service station at Franklin and Vermont, Los Angeles
" 17	100 000.00		296 779.62	172 136.00 (red)	20 925.32		20 879.26	
" 24	100 000.00		252 760.24		443 916.47		128 412.10 (red)	
" 25					122 941.84		204 138.29	
" 26					204 342.03		272 948.76	
" 27	100 000.00					34 332.84		34 332.84
Mar 1		34 332.84		34 332.84		34 332.84		34 332.84
" 1		48 000.00		48 000.00		48 000.00		48 000.00
" 4		10 625.00		10 625.00		10 625.00		239 919.57
" 5								203 185.63
" 6								17 400.43
" 8			209 201.80					
" 10				50 000.00	113 324.49	50 000.00		17 400.43
" 12		50 000.00		50 000.00	53 259.91	7 500.00		
" 18		7 500.00		7 500.00		34 332.43		
" 22		34 332.43		34 332.43		11 427.48		
" 25		50 000.00		50 000.00				
" 28		50 000.00		50 000.00				
Apr 2		50 000.00		50 000.00				
" 3		500.00		500.00				
" 7		4 500.00		4 500.00				8 520.06
" 16		34 332.43		12 369.37				
" 21								
" 26		50 000.00						
" 28		50 000.00						

TABULATION SHOWING TAKINGS OF UNIVERSAL FUNDS
 BY RICHFIELD, ASSETS PURCHASED WITH COMMINGLED FUNDS,
 LOW BALANCES UNDER THREE THEORIES ADVANCED, AND AMOUNT
 TRACEABLE INTO EACH ASSET CLAIMED UNDER EACH THEORY, Continued

(1)	(2)	(3)	(4)	(5)	(6)	(7)	(8)	(9)
Date	Deposit of Universal Money in Richfield Account	Amount Paid on Property for from Commingled Fund	Lowest Daily Closing Balances Between Takings of Universal Funds	Liens Claimed for the Following Sums by Reason of Column 4	Lowest Posted Balances Shown on Bank's Books During Any Day Between Takings of Universal Funds	Liens Claimed for the Following Sums By Reason of Column 6	Lowest Balance Ascertained by Deducting All Checks Cleared Each Day Without Crediting Deposits made During the Same Day	Liens Claimed for the Following Sums by Reason of Column 8
1930								
May 1		\$500.00						Service station at Franklin and Vermont, Los Angeles
" 1		825.00						400 shares capital stock Univ. Cons. Oil Co., cert. # LX 34
" 1		208.33						100 " do " LX 34
" 2		208.33						100 " do " LX 34
" 3		416.67						200 " do " LX 34
" 3		156.25						75 " do " LX 34
" 3		825.00	\$140 878.03					400 " do " LX 34
" 6		41.67						20 " do " LX 34
" 8		41.67						50 " do " LX 34
" 9		104.17						
" 9		500.00						Delaney group producing properties
" 12		104.17						50 shares capital stock Univ. Cons. Oil Co., cert. # LX 34
" 12		5 083.33						2,440 " do " LX 38
" 15		3 125.00						1,500 " do " LX 36
" 19		1 600.00						Land, Sacramento distributing plant, Sacramento, Calif.
" 19		4 375.00						2,100 shares capital stock Univ. Cons. Oil Co., cert. # LX 40
" 20		583.33						200 " do " LX 38
" 20		3 541.67						1,700 " do " LX 39
" 21		20 000.00						Land adjacent Rioco refinery, Hynes, Calif.
" 23		34 332.43						Watson refinery vapor recovery plant, Los Angeles County, Calif.
" 26							\$73 096.23 (red)	
" 27		2 083.33						1,000 shares capital stock Univ. Cons. Oil Co., cert. # L3020
" 27		16 781.25						5,055 " do " LX 42
" 28		7 172.92						3,443 " do " LX 43
Jun 2		500.00						Service station at Franklin and Vermont, Los Angeles
" 4		50 000.00						Delaney group producing properties
" 6	\$75 000.00		168 222.42				114 164.03 (red)	
" 7								
" 18					\$69 303.89			
" 21								
" 25		34 332.43		\$34 332.43		\$34 332.43	122 078.81 (red)	
" 27					45 336.49			
" 28		55 700.19		40 667.57		34 971.46		
Jul 14		34 332.43					1 679 420.83 (red)	
" 15								Rioco refinery storage tanks, Hynes, Calif.
" 17		50 000.00						Watson refinery vapor recovery plant, Los Angeles County, Calif.
" 31		500.00						Delaney group producing properties
	\$1 625 000.00			\$849 864.25		\$664 241.54		\$403 993.92

sho

troi

anc

dep

dra

eac

ing

in

rec

at t

g

ing

Ric

fiel

low

Fir

thro

tru

fiel

wit

That the property into which said trust funds are traced, as set forth in the foregoing tabulation, are hereby identified and described as follows:

Parcel 1. Real property known as "Franklin and Vermont Service Station", in the City of Los Angeles. For description see Receiver's Exhibit "F", page 1.

Parcel 2. Leaseholds known as the Delaney Producing Property, Los Angeles County, California. For description see said Exhibit, page 28 et seq.

Parcels 3 and 4. Ten storage tanks, of which 5 are located on property known as the Hottenroth Property, adjoining the Rioco Refinery at Long Beach, Los Angeles County, California, and 5 are located on property known as the Hunstock Property, adjoining said Rioco Refinery. For description of said tanks and of the real property on which they are located, see said Exhibit, pages 2 and 3. It does not appear that the tanks are a part of the realty, and it is accordingly found that they are not. Parcels 3 and 4, therefore, comprise the 10 tanks, but not the realty.

Parcel 5. Real property known as the Mull Property, in Sacramento County, California. For description see said Exhibit, page 19.

Parcel 6. Vapor Recovery Plant, located on Parcel No. 3 of the Watson Refinery land in Los Angeles County, California. For description of the land on which this plant is located, see said Exhibit commencing at the bottom of page 23. It does not appear that this plant is a part of the realty, and it is accordingly found that it is not. Parcel 6, therefore, comprises the plant, but not the realty.

Parcel 7. 106,000 shares of the capital stock of Universal Consolidated Oil Company, represented by the fol-

lowing certificates, issued to Richfield Oil Company of California:

No. LX26, dated February 13, 1930	42,500 shares;
No. LX27, dated February 14, 1930	50,000 shares;
No. LX28, dated February 14, 1930	2,000 shares;
No. LX32, dated March 10, 1930	11,500 shares;

Parcel 8. 5100 shares of stock of the Universal Consolidated Oil Company, represented by the following certificate issued to Richfield Oil Company of California:

No. LX31, dated March 7, 1930.

Parcel 9. American Steel Tanker "Kekoskee", constructed by the Bethlehem Shipbuilding Corporation (Harlan Plant), Wilmington, Delaware, October, 1920; cargo capacity, 51,200 barrels; port of registration, Los Angeles.

Parcel 10. Real property known as Richmond Terminal and Marine Facilities, situated in Contra Costa County, State of California. For description see said Receiver's Exhibit "F", pages 4 to 16, inclusive.

Also American Steel Tanker "Pat Doheny", constructed by Sun Shipbuilding Company, Chester, Pennsylvania, January, 1921; cargo capacity 80,000 barrels; port of registration, Los Angeles.

Also American Steel Tanker "Larry Doheny", constructed by the Sun Shipbuilding Company, Chester, Pennsylvania, May, 1921; cargo capacity 75,300 barrels; port of registration, Los Angeles, California.

The amount of trust funds belonging to intervenor and traced into the purchase of property acquired by Richfield Oil Company as above described, were as follows:

Parcel 1.	\$ 8500.00
Parcel 2	150,000.00
Parcels 3 and 4	183,207.57
Parcel 5	5,000.00
Parcel 6	115,367.07
Parcel 7	199,500.00
Parcel 8	10,625.00
Parcel 9	35,421.75
Parcel 10	142,242.86
	<hr/>
TOTAL	\$849,864.25

AS TO CONCLUSIONS OF LAW

10. To so much of the Conclusions of Law of the Master as states that a trust be declared and enforced in favor of Universal Consolidated Oil Company (intervenor) in Parcel 1, described on page 83 of the Master's Report, in the sum of \$492.60, or any sum less than \$8,500.00, because under the law and evidence the said Universal Consolidated Oil Company is entitled to have a trust declared and enforced in its favor upon said property described in Parcel 1 in the sum of \$8500.00.

11. To so much of the Conclusions of Law of the Master as states that a trust be declared and enforced in favor of Universal Consolidated Oil Company (intervenor) in Parcel 2, described on page 83 of the Master's Report, in the sum of \$103,442.33, or any sum less than \$150,000.00, because under the law and evidence, the said Universal Consolidated Oil Company is entitled to have a trust declared and enforced in its favor upon said property described in Parcel 2 in the sum of \$150,000.00.

12. To so much of the Conclusions of Law of the Master as states that a trust be declared and enforced in

favor of Universal Consolidated Oil Company (intervenor) in Parcel 3 and Parcel 4, described on page 83 of the Master's report, in the sum of \$91,881.85, or any sum less than \$183,207.57, because under the law and evidence, the said Universal Consolidated Oil Company is entitled to have a trust declared and enforced in its favor upon said property described in Parcels 3 and 4 in the sum of \$183,207.57.

13. To so much of the Conclusions of Law of the Master as states that a trust be declared and enforced in favor of Universal Consolidated Oil Company (intervenor) in Parcel 5, described on page 83 of the Master's Report, in the sum of \$500.00, or any sum less than \$5,000.00, because under the law and evidence, the said Universal Consolidated Oil Company is entitled to have a trust declared and enforced in its favor upon said property described in Parcel 5 in the sum of \$5,000.00.

14. To so much of the Conclusions of Law of the Master as states that a trust be declared and enforced in favor of Universal Consolidated Oil Company (intervenor) in Parcel 6, described on page 83 of the Master's Report, in the sum of \$34,332.84, or any sum less than \$115,367.07, because under the law and evidence, the said Universal Consolidated Oil Company is entitled to have a trust declared and enforced in its favor upon said property described in Parcel 6 in the sum of \$115,367.07.

15. To so much of the Conclusions of Law of the Master as states that a trust be declared and enforced in favor of Universal Consolidated Oil Company (intervenor) in Parcel 7, described on page 83 of the Master's Report, in the sum of \$162,719.30, or any sum less than \$199,500.00, because under the law and evidence, the said

Universal Consolidated Oil Company is entitled to have a trust declared and enforced in its favor upon said property described in Parcel 7 in the sum of \$199,500.00.

16. To so much of the Conclusions of Law of the Master as states that a trust be declared and enforced in favor of Universal Consolidated Oil Company in the properties vested in the Richfield Oil Company and its Receiver, in the sum of \$403,993.92, or any sum less than \$849,864.25, because under the law and evidence the said Universal Consolidated Oil Company is entitled to have a trust declared and enforced in its favor upon the properties vested in the Richfield Oil Company and its Receiver in said sum of \$849,864.25.

17. To the Conclusions of Law and Recommendation of the Master which fail to recommend that a trust be declared and enforced in favor of Universal Consolidated Oil Company upon,

(1) Tanker "Kekoskee", described on page 27 of the Receiver's Exhibit "F", in the sum of \$35,421.75;

(2) Tankers "Pat Doheny" and "Larry Doheny" as described on page 27 of the Receiver's Exhibit "F"; and upon the Richmond Marine Terminal, being the real property described on pages 4, et seq., of said Receiver's Exhibit "F", in the sum and amount of \$142,242.86.

Dated: June 14th, 1933.

A. L. WEIL

LE ROY M. EDWARDS

Attorneys for Claimant and Intervenor Universal Consolidated Oil Company."

Thereafter the exceptions to said Reports were heard and submitted to the United States District Court for the Southern District of California.

ORDERS AND DECREES OF THE UNITED
STATES DISTRICT COURT.

On September 17, 1934 the United States District Court for the Southern District of California, Central Division, entered its order and decree approving and confirming the report of the Special Master filed May 26, 1932 set forth above, and approving and confirming the findings of the Special Master on the claim of Universal Consolidated Oil Company set forth above.

On September 26, 1934, United States District Court for the Southern District of California, Central Division, entered its order and decree approving and confirming the reports of said Special Master upon the claim and upon the bill in intervention of Universal Consolidated Oil Company set forth above, and overruled the exceptions filed by all parties to said Special Master's reports.

It is further agreed and stipulated that the above may constitute the agreed statement of the case to be used on Appeal No. 1, Appeal No. 2 and Appeal No. 3, and that this agreed statement of the case may be used in each of said appeals and that all of said appellants shall be heard thereon in the same manner as if said agreed statement of the case had been filed by the appellants in each case.

Dated this 15th day of March, 1935.

O'MELVENY, TULLER & MYERS,
900 Title Insurance Building,
Los Angeles, California
Clinton La Tourette

Solicitors for Security-First National Bank of Los Angeles, a National Banking Association, as Trustee.

BAUER, MACDONALD, SCHULTHEIS
& PETTIT

621 South Spring Street,
Los Angeles, California

Alexander Macdonald

Solicitors for Richfield Bondholders' Protective Committee.

CHANDLER, WRIGHT & WARD

631 Van Nuys Building,
Los Angeles, California

Leo S. Chandler

CALL & MURPHEY

514 Pacific Mutual Building
Los Angeles, California

Alex W. Davis

Solicitors for Unsecured Creditors Protective Committee—Richfield Oil Company of California.

MUDGE, STERN, WILLIAMS &
TUCKER,

20 Pine Street,
New York, New York

FRESTON & FILES,

650 South Spring Street,
Los Angeles, California

Clarence M. Hanson

Solicitors for The Chase National Bank of the City of New York.

MUDGE, STERN, WILLIAMS &
TUCKER,

20 Pine Street,
New York, New York.

FRESTON & FILES,
650 South Spring Street,
Los Angeles, California

Clarence M. Hanson

Solicitors for Bank of America, a corporation.

CLAYTON T. COCHRAN,
741 Richfield Building,
Los Angeles, California

Clayton T. Cochran

Solicitor for Pan American Petroleum Company a corporation.

GIBSON, DUNN & CRUTCHER,
634 South Spring Street,
Los Angeles, California

Homer D. Crotty

Solicitors for William C. McDuffie as Receiver for Pan American Petroleum Company.

MORTIMER A. KLINE,
Union Oil Building,
Los Angeles, California

Mortimer A. Kline

Special Solicitor for William C. McDuffie as Receiver of Pan American Petroleum Company.

WILLIAM J. De MARTINI,

306 Richfield Building,
Los Angeles, California

Wm. J. De Martini

Solicitor for Richfield Oil Company of California, a corporation.

ATLEE POMERENE,

H. J. CRAWFORD,

FRANK HARRISON,

Special Assistants to the Attorney General of the United States.

Union Trust Building,
Cleveland, Ohio

PEIRSON M. HALL,

United States Attorney.

508 Federal Building,
Los Angeles, California

JOHN R. LAYNG,

Special Assistant United States Attorney.

1018 Board of Trade Building,
Los Angeles, California

John R. Layng

Solicitors for United States of America.

CHANDLER, WRIGHT & WARD,

631 Van Nuys Building,
Los Angeles, California

Leo S. Chandler

Solicitors for The Republic Supply Company of California, a corporation.

HILL, MORGAN & BLEDSOE,

639 Roosevelt Building,
Los Angeles, California

ELVON MUSICK,

Subway Terminal Building,
Los Angeles, California

George Martinson

Solicitors for Cities Service Company, a corporation.

A. L. WEIL,

108 West Second Street,
Los Angeles, California

LeROY M. EDWARDS,

810 South Flower Street,
Los Angeles, California

By Martin J. Weil

Solicitors for Universal Consolidated Oil Company, a corporation.

COLIN C. IVES,

621 South Spring Street,
Los Angeles, California

CRAVATH, deGERSDORFF, SWAINE &
WOOD,

15 Broad Street,
New York, New York

Colin C. Ives

Solicitors for Robert C. Adams, Thomas B. Eastland,
Edward F. Hayes and Richard W. Millar (known
and designated as Pan American Bondholders' Com-
mittee)

BAUER, MACDONALD, SCHULTHEIS
& PETTIT,

621 South Spring Street,
Los Angeles, California

CRAVATH, deGERSDORFF, SWAINE &
WOOD,

15 Broad Street,
New York, New York

CHANDLER, WRIGHT & WARD,

631 Van Nuys Building,
Los Angeles, California

CALL & MURPHEY,

Pacific Mutual Building,
Los Angeles, California

Alexander Macdonald,

Colin C. Ives,

Alex W. Davis

Leo S. Chandler,

Solicitors for G. Parker Toms, Robert C. Adams, F. S. Baer, Robert E. Hunter, Henry S. McKee and Richard W. Millar (known and designated as Richfield-Pan American Reorganization Committee).

CALL & MURPHEY,

514 Pacific Mutual Building,
Los Angeles, California

Alex W. Davis

Solicitors for Security-First National Bank of Los Angeles, a national banking association, Pacific American Company, a corporation, American Company, a corporation, Manufacturers Trust Company of New

York, a corporation, Citizens National Trust & Savings Bank of Los Angeles, a national banking association, First National Bank and Trust Company of Seattle, a national banking association, Continental Illinois Bank and Trust Company, a corporation, The First National Bank of Chicago, a national banking association, Chemical National Bank and Trust Company, a national banking association, and California Bank, a corporation.

GIBSON, DUNN & CRUTCHER,

634 South Spring Street,
Los Angeles, California

Homer D. Crotty

Solicitors for William C. McDuffie, as Receiver of Richfield Oil Company of California, a corporation

Approved this 16th day of March, 1935; and ordered when filed in the office of the Clerk of this Court to supersede, for the purposes of the appeals herein, all parts of the record in these causes other than said orders and decrees appealed from; and further ordered to be copied, together with said orders and decrees, and certified to the United States Circuit Court of Appeals for the Ninth Circuit as the record on the appeal herein.

Wm. P. James

District Judge

[Endorsed]: Filed Mar 16 1935 R. S. Zimmerman,
Clerk By Edmund L. Smith Deputy Clerk

IN THE DISTRICT COURT OF THE UNITED
STATES FOR THE SOUTHERN DISTRICT
OF CALIFORNIA, CENTRAL DIVISION.

THE REPUBLIC SUPPLY COM-)
PANY OF CALIFORNIA, a cor-)
poration,)

Complainant,)

vs.)

RICHFIELD OIL COMPANY OF)
CALIFORNIA, a corporation,)

Defendant.)

SECURITY - FIRST NATIONAL)
BANK OF LOS ANGELES, a na-)
tional banking association, as trustee,)

Plaintiff,)

vs.)

RICHFIELD OIL COMPANY OF)
CALIFORNIA, a corporation, and)
WILLIAM McDUFFIE, as Re-)
ceiver of Richfield Oil Company of)
California, a corporation,)

Defendants.)

UNIVERSAL CONSOLIDATED)
OIL COMPANY, a California cor-)
poration,)

Intervenor.)

IN EQUITY
CONSOLIDATED
CAUSE
NO. S-125-J.

PETITION
FOR APPEAL.

TO THE HONORABLE WILLIAM P. JAMES,
JUDGE OF THE DISTRICT COURT OF THE
UNITED STATES, FOR THE SOUTHERN
DISTRICT OF CALIFORNIA:

Security-First National Bank of Los Angeles, a national banking association, as trustee, plaintiff herein, George Armsby, F. S. Baer, Harry J. Bauer, Stanton Griffis, Robert E. Hunter and Albert E. Van Court constituting the Richfield Bondholders' Committee, a committee formerly and at the time of the filing of the claim of Richfield Bondholders' Committee herein referred to constituted of Nion R. Tucker, George Armsby, Stanton Griffis, Robert E. Hunter and Harry J. Bauer, interveners herein, and each of them, petitioners herein, considering themselves aggrieved by that certain order, judgment and decree made and entered by the court in the above entitled cause on September 17, 1934, adjudicating each, all and sundry the exceptions filed to the Report of the Honorable William A. Bowen, Special Master in said cause, with reference to the bill in intervention of Universal Consolidated Oil Company, which report was filed on May 26, 1933, do hereby appeal from said order, judgment and decree to the United States Circuit Court of Appeals for the Ninth Circuit, for the reason specified in their assignment of errors, which is filed herewith, and pray that their appeal may be allowed and that a transcript of the record, proceedings and papers upon which said order, judgment and decree were based and made, duly authenticated, may

be sent to the United States Circuit Court of Appeals for the Ninth Circuit, sitting at San Francisco in said Circuit, and your petitioners further pray that the proper order touching the security to be required of petitioners to perfect their said appeal be made.

Dated at Los Angeles, California, this 17th day of December, 1934, in Open Court.

O'MELVENY, TULLER & MYERS,
 LOUIS W. MYERS,
 PIERCE WORKS,
 BAUER, MACDONALD, SCHULTHEIS
 & PETTIT,
 ALEXANDER MACDONALD,
 A. STEVENS HALSTED, JR.

O'Melveny, Tuller & Myers,
 Louis W. Myers,
 Pierce Works,
 Bauer, Macdonald, Schultheis & Pettit,
 Alexander Macdonald,
 A. Stevens Halsted, Jr.

Solicitors for Petitioners above named.

[Endorsed]: Filed Dec. 17, 1934. R. S. Zimmerman,
 Clerk By Edmund L. Smith, Deputy Clerk.

[TITLE OF COURT AND CAUSE.]

ASSIGNMENT OF ERRORS.

Now come Security-First National Bank of Los Angeles, a national banking association, as trustee, plaintiff herein, George Armsby, F. S. Baer, Harry J. Bauer, Stanton Griffis, Robert E. Hunter and Albert E. Van Court constituting the Richfield Bondholders' Committee, a committee formerly and at the time of the filing of the claim of Richfield Bondholders' Committee herein referred to constituted of Nion R. Tucker, George Armsby, Stanton Griffis, Robert E. Hunter and Harry J. Bauer, interveners herein, petitioners and appellants in the above entitled action, and having prayed for the allowance of their appeal to the United States Circuit Court of Appeals for the Ninth Circuit from the order, judgment and decree of the above entitled United States District Court entered in said cause on September 17, 1934, adjudicating each, all and sundry the exceptions filed to the Report of Honorable William A. Bowen, Special Master in said cause, with reference to the bill in intervention of Universal Consolidated Oil Company, which report was filed on May 26, 1933, all as is more particularly set forth in the petition presented herewith, and respectfully represent and say that said order, judgment and decree is erroneous and unjust to said appellants, and each of them, in the following particulars, and respectfully present and file the following as the assignment of errors upon which they, and each of them, will rely in the prosecution of said appeal, to-wit:

1. The court erred in approving and confirming the Report of the Honorable William A. Bowen, Special Master in the above entitled cause, on the bill in interven-

tion of Universal Consolidated Oil Company, which report was filed in the office of the Clerk of the above entitled court on May 26, 1933.

2. The court erred in not sustaining and allowing each, all and sundry the exceptions filed in said cause to said report by Security-First National Bank of Los Angeles as trustee, petitioner herein.

3. The court erred in approving and confirming the finding of fact and/or conclusion of law in said report (Report p. 82, line 26) that the lien of the bond or trust indenture sought to be foreclosed herein is subject to the trust interest of Universal Consolidated Oil Company, intervenor, as found and declared by said Special Master as to the parcels of property specified in said Report.

4. The court erred in approving and confirming the finding of fact and/or conclusion of law in said Report (Report p. 76, line 24) that said intervenor had sufficiently identified and traced its funds into the various parcels specified in said Report and hereinafter specified either in the amounts therein set forth or otherwise.

5. The court erred in approving and confirming the finding of fact and/or conclusion of law in said Report (Report p. 57, line 13) that the various parcels specified in said Report and hereinafter specified either in toto or to the respective amounts or to the extent of the trust imposed upon this in favor of said intervenor, constitute the property of intervenor in a substituted form.

6. The court erred in approving and confirming the conclusion of law in said Report (Report p. 83, line 4) that said intervenor is entitled to have a trust imposed upon the various parcels specified in said Report and here-

inafter specified either in the amounts specified therein or in any amounts whatsoever.

7. The court erred in approving and confirming the conclusion of law in said Report (Report p. 76, line 24) that the evidence herein constitutes a sufficient tracing and identification of funds of said intervenor to warrant the imposition of a trust in favor of said intervenor upon the various parcels specified in said Report and hereinafter specified, either in the amounts set forth therein or in any amounts whatsoever.

8. The court erred in approving and confirming the conclusion of law in said Report (Report p. 67-a, line 6) that the investments revealed by the evidence (to-wit, the purchases by defendant Richfield Oil Company of California, a corporation, of the parcels specified in said Report and hereinafter specified) should be attributed either in whole or in part to the trust funds of intervenor then and there in the possession of said defendant and commingled with private funds belonging to said defendant.

9. The court erred in approving and confirming the conclusion of law in said Report (Report p. 67-a, line 6) that in the case of purchases of real or personal property made by a trustee out of a fund in which trust and private funds had theretofore been commingled, the trust moneys may be traced into such properties wholly through the application of presumptions and wholly without evidence of any actual devotion of such trust funds or any part

thereof as distinguished from the commingled funds to the respective purchases in question.

10. The court erred in not concluding that the evidence was insufficient to support a finding that intervenor had actually traced into the parcels specified in said Report and hereinafter specified any of the trust funds of intervenor formerly in the possession of defendant Richfield Oil Company of California, a corporation, as distinguished from the commingled fund in which said trust funds and the private funds of said defendant were blended.

11. The court erred in not concluding and declaring that mere proof of purchases out of a fund in which trust and private moneys have been commingled is wholly insufficient to warrant the imposition of a trust upon the property so purchased.

12. The court erred in approving and confirming the recommendations and each of them contained in said Report (p. 83, line 4) to-wit:

(a) That a trust be declared and enforced in favor of Universal Consolidated Oil Company, a corporation, in the amounts specified below and upon such right, title and interest as may appear to be vested in Richfield Oil Company of California, a corporation, and its receiver, and superior to any right, title, interest or lien of this plaintiff under the bond or trust indenture sought to be foreclosed herein in and to the following properties and parcels described in said report, to-wit:

<u>Parcel 1:</u>	“Franklin & Vermont Service Station”, real property.	\$ 492.60
<u>Parcel 2:</u>	“Delaney Producing Property”, leaseholds.	103,442.33
<u>Parcels 3 and 4</u>	Ten storage tanks, personal property.	91,881.85
<u>Parcel 5:</u>	“Mul! Property” real property.	500.00
<u>Parcel 6:</u>	“Vapor Recovery Plant,” personal property.	34,332.84
<u>Parcel 7:</u>	106,000 shares of Universal Stock, Certs. LX:26, 27, 28 and 32	162,719.30
<u>Parcel 8:</u>	5,100 shares of Universal stock. Cert. LX 31	10,625.00
		<hr/> \$403,993.92

(b) That upon any sale to be had in this action the aforesaid parcels be offered for sale and sold separately from each other and from all other property, and that Universal Consolidated Oil Company be allowed a first charge upon the gross proceeds of the sale of each of said parcels in the amount above specified in respect thereof, the amount of each sale to be a charge upon any surplus realized from such sale over the amount receivable as aforesaid by said Universal Consolidated Oil Company, a corporation; and

(c) That jurisdiction be retained for the purpose of awarding such other relief as may appear to be equitable for the enforcement of said trust in the event there shall

be a failure to effect a sale in the case of any parcel or parcels.

13. The court erred in failing and declining to adjudicate, decide and determine that said intervenor is not entitled to have a trust imposed upon any of the parcels specified in said Report in any amount whatever.

WHEREFORE, petitioners and appellants and each of them pray that said order, judgment and decree may be reversed, and for such other and further relief as to the court may seem just and proper.

Dated this 17th day of December, 1934.

O'MELVENY, TULLER & MYERS,
 LOUIS W. MYERS,
 PIERCE WORKS,
 BAUER, MACDONALD, SCHULTHEIS
 & PETTIT,
 ALEXANDER MACDONALD,
 A. STEVENS HALSTED, JR.,

O'Melveny, Tuller & Myers,
 Louis W. Myers,
 Pierce Works,
 Bauer, Macdonald, Schultheis & Pettit,
 Alexander MacDonald,
 A. Stevens Halsted, Jr.,

Solicitors for Petitioners and Appellants above named.

[Endorsed]: Filed Dec. 17, 1934. R. S. Zimmerman,
 Clerk By Edmund L. Smith, Deputy Clerk.

[TITLE OF COURT AND CAUSE.]

ORDER ALLOWING APPEAL.

The petition of Security-First National Bank of Los Angeles, a national banking association, as trustee, plaintiff herein, George Armsby, F. S. Baer, Harry J. Bauer, Stanton Griffis, Robert E. Hunter and Albert E. Van Court constituting the Richfield Bondholders' Committee, a committee formerly and at the time of the filing of the claim of Richfield Bondholders' Committee herein referred to constituted of Nion R. Tucker, George Armsby, Stanton Griffis, Robert E. Hunter and Harry J. Bauer, interveners herein; for an order allowing their appeal to the United States Circuit Court of Appeals for the Ninth Circuit from that certain order, judgment and decree of this court made and entered in the above entitled cause on September 17, 1934, adjudicating each, all and sundry the exceptions filed to the Report of the Honorable William A. Bowen, Special Master in said cause, with reference to the bill in intervention of Universal Consolidated Oil Company, which Report was filed on May 26, 1933, all as more particularly set forth in said petition, is hereby granted and such appeal is allowed as prayed for; and

IT IS FURTHER ORDERED that a certified transcript of the record, proceedings and papers upon which said order, judgment and decree was based, duly authen-

ticated, be transmitted to the said United States Circuit Court of Appeals for the Ninth Circuit, sitting at San Francisco in said Circuit; and

IT IS FURTHER ORDERED that said petitioners furnish a bond for costs on appeal in the sum of \$1000.00, with sufficient sureties, to be conditioned as required by law.

Done at Los Angeles, California, this 17 day of December, 1934, in Open Court.

Wm. P. James

UNITED STATES DISTRICT JUDGE.

[Endorsed]: Filed Dec. 17, 1934 R. S. Zimmerman,
Clerk By Edmund L. Smith Deputy Clerk.

[TITLE OF COURT AND CAUSE.]

BOND ON APPEAL.

KNOW ALL MEN BY THESE PRESENTS:

That the undersigned, NATIONAL SURETY CORPORATION, a corporation organized and existing under the laws of the State of New York, and duly qualified to do and to transact a general surety business in the State of California, and as well in the Southern United States Judicial District of the State of California, acknowledges itself to be indebted to The Chase National Bank of the City of New York, a national banking association, Bank of America, a corporation, Pan American Petroleum Company, a corporation, William C. McDuffie, as Receiver of Richfield Oil Company of California, a corporation, William C. McDuffie, as Receiver of Pan American Petroleum Company, a corporation, Richfield Oil Company of California, a corporation, The United States of America, The Republic Supply Company of California, a corporation, Cities Service Company, a corporation, Universal Consolidated Oil Company, a corporation, M. W. Lowery, Henry S. McKee, O. C. Field and R. R. Templeton (known and designated as Richfield Unsecured Creditors' Committee), Robert C. Adams, Thomas B. Eastland, Edward F. Hayes and Richard W. Millar (known and designated as Pan American Bondholders' Committee), G. Parker Toms, Robert C. Adams, F. S. Baer, Robert E. Hunter, Henry S. McKee and Richard W. Millar (known and designated

as Richfield-Pan American Reorganization Committee), Security-First National Bank of Los Angeles, a national banking association, Pacific American Company, a corporation, American Company, a corporation, Manufacturers Trust Company of New York, a corporation, Citizens National Trust & Savings Bank of Los Angeles, a national banking association, First National Bank and Trust Company of Seattle, a national banking association, Continental Illinois Bank and Trust Company, a corporation, The First National Bank of Chicago, a national banking association, Chemical National Bank and Trust Company, a national banking association, and California Bank, a corporation, appellees in the above cause, jointly but not severally, in the sum of one thousand—(\$1,000.00) conditioned that:

WHEREAS, on September 17, 1934, in the above entitled action in the above entitled court said court made and entered its order, judgment and decree adjudicating each, all and sundry the exceptions filed to the Report of the Honorable William A. Bowen, Special Master in said cause, with reference to the bill in intervention of Universal Consolidated Oil Company, which Report was filed on May 26, 1933, and the parties appellant hereinafter named, have been allowed leave to appeal to the United States Circuit Court of Appeals for the Ninth Circuit to reverse said order, judgment and decree.

Now if said parties appellant, to-wit, Security-First National Bank of Los Angeles, a national banking asso-

ciation, as trustee, plaintiff herein, George Armsby, F. S. Baer, Harry J. Bauer, Stanton Griffis, Robert E. Hunter and Albert E. Van Court constituting the Richfield Bondholders' Committee, a committee formerly and at the time of the filing of the claim of Richfield Bondholders' Committee herein referred to constituted of Nion R. Tucker, George Armsby, Stanton Griffis, Robert E. Hunter and Harry J. Bauer, interveners herein, shall prosecute their said appeal to effect and answer all costs, if they fail to make their plea good, then the above obligation to be void, else to remain in full force and virtue.

In no event shall liability or recovery on this bond exceed in the aggregate the sum of Dollars (\$1,000.00).

IN WITNESS WHEREOF, the said National Surety Corporation has caused its name to be hereunto subscribed and its corporate seal to be affixed by its attorney in fact thereunto duly authorized this 17th day of December, 1934.

[Seal] NATIONAL SURETY CORPORATION,

By Arden L. Day

Its Attorney in Fact.

The form of the foregoing bond and sufficiency of surety thereof are approved this 17 day of December, 1934.

Wm P James

United States District Judge.

STATE OF CALIFORNIA)
 (SS.
 COUNTY OF LOS ANGELES)

On this 17th day of December in the year one thousand nine hundred and 34 before me Frances T. Mixson, a Notary Public in and for said County and State, residing therein, duly commissioned and sworn, personally appeared Arden L. Day, known to me to be the duly authorized attorney-in-fact of NATIONAL SURETY CORPORATION, and the same person whose name is subscribed to the within instrument as the Attorney-in-Fact of said Corporation, and the said Arden L. Day acknowledged to me that he subscribed the name of National Surety Corporation thereto as principal, and his own name as attorney-in-fact.

IN WITNESS WHEREOF, I have hereunto set my hand and affixed my official seal the day and year in this certificate first above written.

[Seal]

Frances T. Mixson,

Notary Public in and for said county and state.

My Commission expires August 31, 1936.

[Endorsed]: Filed Dec. 17, 1934. R. S. Zimmerman,
 Clerk By Edmund L. Smith, Deputy Clerk.

IN THE DISTRICT COURT OF THE UNITED STATES FOR THE SOUTHERN DISTRICT OF CALIFORNIA CENTRAL DIVISION

THE REPUBLIC SUPPLY COM-)
 PANY OF CALIFORNIA, a cor-)
 poration,)
 Complainant,)

vs.)

RICHFIELD OIL COMPANY OF)
 CALIFORNIA, a corporation,)
 Defendant.)

IN EQUITY)
 CONSOLIDATED)
 CAUSE)
 NO. S-125-J)

SECURITY-FIRST NATIONAL)
 BANK OF LOS ANGELES, a na-)
 tional banking association, as trustee,)

Plaintiff,)

vs.)

RICHFIELD OIL COMPANY OF)
 CALIFORNIA, a corporation, and)
 WILLIAM McDUFFIE, as Re-)
 ceiver of Richfield Oil Company of)
 California, a corporation,)

Defendants.)

PETITION FOR)
 APPEAL)
 (Order of Septem-)
 ber 26, 1934))

UNIVERSAL CONSOLIDATED)
 OIL COMPANY, a California cor-)
 poration,)
)
 Intervenor.)
)

TO THE HONORABLE WILLIAM P. JAMES,
 JUDGE OF THE DISTRICT COURT OF THE
 UNITED STATES, FOR THE SOUTHERN
 DISTRICT OF CALIFORNIA:

Security-First National Bank of Los Angeles, a national banking association, as trustee, plaintiff herein, George Armsby, F. S. Baer, Harry J. Bauer, Stanton Griffis, Robert E. Hunter and Albert E. Van Court constituting the Richfield Bondholders' Committee, a committee formerly and at the time of the filing of the claim of Richfield Bondholders' Committee herein constituted of Nion R. Tucker, George Armsby, Stanton Griffis, Robert E. Hunter and Harry J. Bauer, interveners herein, and each of them, petitioners herein, considering themselves aggrieved by that certain order, judgment and decree made and entered by the court in the above entitled cause on September 26, 1934, adjudicating each, all and sundry the exceptions filed to the Report of the Honorable William A. Bowen, Special Master in said cause, with reference to the bill in intervention of Universal Consolidated Oil Company, which report was filed on May 26,

1933, do hereby appeal from said order, judgment and decree to the United States Circuit Court of Appeals for the Ninth Circuit, for the reason specified in their assignment of errors, which is filed herewith, and pray that their appeal may be allowed and that a transcript of the record, proceedings and papers upon which said order, judgment and decree were based and made, duly authenticated, may be sent to the United States Circuit Court of Appeals for the Ninth Circuit, sitting at San Francisco in said Circuit, and your petitioners further pray that the proper order touching the security to be required of petitioners to perfect their said appeal be made.

Dated at Los Angeles, California, this 26th day of December, 1934, in Open Court.

O'MELVENY, TULLER & MYERS,
LOUIS W. MYERS,
PIERCE WORKS,
BAUER, MACDONALD, SCHULTHEIS
& PETTIT,
ALEXANDER MACDONALD,
A. STEVENS HALSTED, JR.

By Pierce Works

Solicitors for Petitioners above named.

[Endorsed]: Filed Dec. 26, 1934. R. S. Zimmerman,
Clerk By Edmund L. Smith, Deputy Clerk

[TITLE OF COURT AND CAUSE.]

ASSIGNMENT OF ERRORS
(Order of September 26, 1934)

Now come Security-First National Bank of Los Angeles, a national banking association, as trustee, plaintiff herein, George Armsby, F. S. Baer, Harry J. Bauer, Stanton Griffis, Robert E. Hunter and Albert E. Van Court constituting the Richfield Bondholders' Committee, a committee formerly and at the time of the filing of the claim of Richfield Bondholders' Committee herein constituted of Nion R. Tucker, George Armsby, Stanton Griffis, Robert E. Hunter and Harry J. Bauer, interveners herein, petitioners and appellants in the above entitled action, and having prayed for the allowance of their appeal to the United States Circuit Court of Appeals for the Ninth Circuit from the order, judgment and decree of the above entitled United States District Court entered in said cause on September 26, 1934, adjudicating each, all and sundry the exceptions filed to the Report of Honorable William A. Bowen, Special Master in said cause, with reference to the bill in intervention of Universal Consolidated Oil Company, which report was filed on May 26, 1933, all as is more particularly set forth in the petition presented herewith, and respectfully represent and say that said order, judgment and decree is erroneous and unjust to said appellants, and each of them, in the following particulars, and respectfully present and file the following as the assignment of errors upon which they, and each of them, will rely in the prosecution of said appeal, to-wit:

1. The court erred in giving and rendering its order or decree of September 26, 1934 in the above entitled suit which order approved and confirmed the Report of William A. Bowen, Special Master, filed in the office of the clerk of the above entitled court on May 26, 1933, on the bill in intervention of Universal Consolidated Oil Company and overruled exceptions to said Report.

2. The court erred in not sustaining and allowing each, all and sundry the exceptions filed in said cause to said report by Security-First National Bank of Los Angeles as trustee, petitioner herein.

3. The court erred in approving and confirming the finding of fact and/or conclusion of law in said report (Report p. 82, line 26) that the lien of the bond or trust indenture sought to be foreclosed herein is subject to the trust interest of Universal Consolidated Oil Company, intervenor, as found and declared by said Special Master as to the parcels of property specified in said Report.

4. The court erred in approving and confirming the finding of fact and/or conclusion of law in said Report (Report p. 76, line 24) that said intervenor had sufficiently identified and traced its funds into the various parcels specified in said Report and hereinafter specified either in the amounts therein set forth or otherwise.

5. The court erred in approving and confirming the finding of fact and/or conclusion of law in said Report (Report p. 57, line 13) that the various parcels specified in said Report and hereinafter specified either in toto or in the respective amounts or to the extent of the trust imposed upon this in favor of said intervenor, constitute the property of intervenor in a substituted form.

6. The court erred in approving and confirming the conclusion of law in said Report (Report p. 83, line 4) that said intervenor is entitled to have a trust imposed upon the various parcels specified in said Report and hereinafter specified either in the amounts specified therein or in any amounts whatsoever.

7. The court erred in approving and confirming the conclusion of law in said Report (Report p. 76, line 24) that the evidence herein constitutes a sufficient tracing and identification of funds of said intervenor to warrant the imposition of a trust in favor of said intervenor upon the various parcels specified in said Report and hereinafter specified, either in the amounts set forth therein or in any amounts whatsoever.

8. The court erred in approving and confirming the conclusion of law in said Report (Report p. 67-a, line 6) that the investments revealed by the evidence (to-wit, the purchases by defendant Richfield Oil Company of California, a corporation, of the parcels specified in said Report and hereinafter specified) should be attributed either in whole or in part to the trust funds of intervenor then and there in the possession of said defendant and commingled with private funds belonging to said defendant.

9. The court erred in approving and confirming the conclusion of law in said Report (Report p. 67-a, line 6) that in the case of purchases of real or personal property made by a trustee out of a fund in which trust and private funds had theretofore been commingled, the trust moneys may be traced into such properties wholly through the application of presumptions and wholly without evidence of any actual devotion of such trust funds or any part thereof

as distinguished from the commingled funds to the respective purchases in question.

10. The court erred in not concluding that the evidence was insufficient to support a finding that intervenor had actually traced into the parcels specified in said Report and hereinafter specified any of the trust funds of intervenor formerly in the possession of defendant Richfield Oil Company of California, a corporation, as distinguished from the commingled fund in which said trust funds and the private funds of said defendant were blended.

11. The court erred in not concluding and declaring that mere proof of purchases out of a fund in which trust and private moneys have been commingled is wholly insufficient to warrant the imposition of a trust upon the property so purchased.

12. The court erred in approving and confirming the recommendations and each of them contained in said Report (p. 83, line 4) to-wit:

(a) That a trust be declared and enforced in favor of Universal Consolidated Oil Company, a corporation, in the amounts specified below and upon such right, title and interest as may appear to be vested in Richfield Oil Company of California, a corporation, and its receiver, and superior to any right, title, interest or lien of this plaintiff under the bond or trust indenture sought to be foreclosed herein in and to the following properties and parcels described in said Report, to-wit:

<u>Parcel 1:</u>	“Franklin & Vermont Service Station”, real property.	\$ 492.60
<u>Parcel 2:</u>	“Delaney Producing Property”, leaseholds.	103,442.33
<u>Parcels 3 and 4:</u>	Ten storage tanks, personal property.	91,881.85
<u>Parcel 5:</u>	“Mull Property” real property.	500.00
<u>Parcel 6:</u>	“Vapor Recovery Plant,” personal property.	34,332.84
<u>Parcel 7:</u>	106,000 shares of Universal Stock, Certs. LX:26, 27, 28 and 32.	162,719.30
<u>Parcel 8:</u>	5,100 shares of Universal stock, Cert. LX 31.	10,625.00
		<hr/>
		\$403,993.92

(b) That upon any sale to be had in this action the aforesaid parcels be offered for sale and sold separately from each other and from all other property, and that Universal Consolidated Oil Company be allowed a first charge upon the gross proceeds of the sale of each of said parcels in the amount above specified in respect thereof, the amount of each sale to be a charge upon any surplus realized from such sale over the amount receivable as aforesaid by said Universal Consolidated Oil Company, a corporation; and

(c) That jurisdiction be retained for the purpose of awarding such other relief as may appear to be equitable for the enforcement of said trust in the event there shall be a failure to effect a sale in the case of any parcel or parcels.

13. The court erred in failing and declining to adjudicate, decide and determine that said intervenor is not entitled to have a trust imposed upon any of the parcels specified in said Report in any amount whatever.

WHEREFORE, petitioners and appellants and each of them pray that said order, judgment and decree may be reversed, and for such other and further relief as to the court may seem just and proper.

Dated this 26th day of December, 1934.

O'MELVENY, TULLER & MYERS,
 LOUIS W. MYERS,
 PIERCE WORKS,
 BAUER, MACDONALD, SCHULTHEIS
 & PETTIT,
 ALEXANDER MACDONALD,
 A. STEVENS HALSTED, JR.

By Pierce Works

Solicitors for Petitioners and Appellants above named.

[Endorsed]: Filed Dec. 26, 1934. R. S. Zimmerman
 Clerk By Edmund L. Smith, Deputy Clerk

[TITLE OF COURT AND CAUSE.]

ORDER ALLOWING APPEAL

(Order of September 26, 1934)

The petition of Security-First National Bank of Los Angeles, a national banking association, as trustee, plaintiff herein, George Armsby, F. S. Baer, Harry J. Bauer, Stanton Griffis, Robert E. Hunter and Albert E. Van Court constituting the Richfield Bondholders' Committee, a committee formerly and at the time of the filing of the claim of Richfield Bondholders' Committee herein constituted of Nion R. Tucker, George Armsby, Stanton Griffis, Robert E. Hunter and Harry J. Bauer, interveners herein, for an order allowing their appeal to the United States Circuit Court of Appeals for the Ninth Circuit from that certain order, judgment and decree of this court made and entered in the above entitled cause on September 26, 1934, adjudicating each, all and sundry the exceptions filed to the Report of the Honorable William A. Bowen, Special Master in said cause, with reference to the bill in intervention of Universal Consolidated Oil Company, which Report was filed on May 26, 1933, all as more particularly set forth in said petition, is hereby granted and such appeal is allowed as prayed for; and

IT IS FURTHER ORDERED that a certified transcript of the record, proceedings and papers upon which said order, judgment and decree was based, duly authenticated, be transmitted to the said United States Circuit Court of Appeals for the Ninth Circuit, sitting at San Francisco in said Circuit; and

IT IS FURTHER ORDERED that said petitioners furnish a bond for costs on appeal in the sum of \$500— with sufficient sureties, to be conditioned as required by law.

Done at Los Angeles, California, this 26th day of December, 1934, in Open Court.

Wm P. James
United States District Judge.

[Endorsed]: Filed Dec. 26, 1934. R. S. Zimmerman
Clerk By Edmund L. Smith, Deputy Clerk.

[TITLE OF COURT AND CAUSE.]

BOND ON APPEAL

(Order of September 26, 1934)

KNOW ALL MEN BY THESE PRESENTS:

That the undersigned, NATIONAL SURETY CORPORATION, a corporation organized and existing under the laws of the State of New York, and duly qualified to do and to transact a general surety business in the State of California, and as well in the Southern United States Judicial District of the State of California, acknowledges itself to be indebted to The Chase National Bank of the City of New York, a national banking association, Bank of America, a corporation, Pan American Petroleum Company, a corporation, William C. McDuffie, as Receiver of Richfield Oil Company of California, a corporation, William C. McDuffie, as Receiver of Pan American Petroleum Company, a corporation, Richfield Oil Company of California, a corporation, The United States of America, The Republic Supply Company of California, a corporation, Cities Service Company, a corporation, Universal Consolidated Oil Company, a corporation, M. W. Lowery, Henry S. McKee, O. C. Field and R. R. Templeton (known and designated as Richfield Unsecured Creditors' Committee), Robert C. Adams, Thomas B. Eastland, Edward F. Hayes and Richard W. Millar (known and designated as Pan American Bondholders' Committee), G. Parker Toms, Robert C. Adams, F. S. Baer, Robert E. Hunter, Henry S. McKee and Richard W. Millar (known and designated as Richfield-Pan American Reorganization Committee), Security-First National Bank of Los Angeles, a

national banking association, Pacific American Company, a corporation, American Company, a corporation, Manufacturers Trust Company of New York, a corporation, Citizens National Trust & Savings Bank of Los Angeles, a national banking association, First National Bank and Trust Company of Seattle, a national banking association, Continental Illinois Bank and Trust Company, a corporation, The First National Bank of Chicago, a national banking association, Chemical National Bank and Trust Company, a national banking association, and California Bank, a corporation, appellees in the above cause, jointly but not severally, in the sum of five hundred dollars (\$500.00) conditioned that:

WHEREAS, on September 26, 1934, in the above entitled action in the above entitled court said court made and entered its order, judgment and decree adjudicating each, all and sundry the exceptions filed to the Report of the Honorable William A. Bowen, Special Master in said cause, with reference to the bill in intervention of Universal Consolidated Oil Company, which Report was filed on May 26, 1933, and the parties appellant hereinafter named, have been allowed leave to appeal to the United States Circuit Court of Appeals for the Ninth Circuit to reverse said order, judgment and decree.

Now if said parties appellant, to-wit, Security-First National Bank of Los Angeles, a national banking association, as trustee, plaintiff herein, George Armsby, F. S. Baer, Harry J. Bauer, Stanton Griffis, Robert E. Hunter

and Albert E. Van Court constituting the Richfield Bondholders' Committee, a committee formerly and at the time of the filing of the claim of Richfield Bondholders' Committee herein constituted of Nion R. Tucker, George Armsby, Stanton Griffis, Robert E. Hunter and Harry J. Bauer, interveners herein, shall prosecute their said appeal to effect and answer all costs, if they fail to make their plea good, then the above obligation to be void, else to remain in full force and virtue.

In no event shall liability or recovery on this bond exceed in the aggregate the sum of five hundred dollars (\$500.00).

IN WITNESS WHEREOF, the said National Surety Corporation has caused its name to be hereunto subscribed and its corporate seal to be affixed by its attorney in fact thereunto duly authorized this 26th day of December, 1934.

[Seal] NATIONAL SURETY CORPORATION,

By Chas. Seyler, Jr.

Its Attorney in Fact.

The form of the foregoing bond and sufficiency of surety thereof are approved this 26th day of December, 1934.

Wm P. James

United States District Judge.

State of California)
 County of Los Angeles) ss.

On this 26th day of December in the year one thousand nine hundred and 34, before me Francis T. Mixson, a Notary Public in and for said County and State, residing therein, duly commissioned and sworn, personally appeared Chas. Seyler, Jr. known to me to be the duly authorized Attorney in Fact of NATIONAL SURETY CORPORATION, and the same person whose name is subscribed to the within instrument as the Attorney in Fact of said Corporation and the said Chas. Seyler Jr. acknowledged to me that he subscribed the name of NATIONAL SURETY CORPORATION thereto as principal and his own name as Attorney in Fact.

IN WITNESS WHEREOF, I have hereunto set my hand and affixed my official seal the day and year in this certificate first above written.

[Seal]

Francis T. Mixson

Notary Public in and for said County and State.

My Commission Expires August 31, 1936

[Endorsed]: Filed Dec. 26, 1934. R. S. Zimmerman
 Clerk By Edmund L. Smith, Deputy Clerk.

IN THE DISTRICT COURT OF THE UNITED
STATES FOR THE SOUTHERN DISTRICT
OF CALIFORNIA, CENTRAL
DIVISION.

THE REPUBLIC SUPPLY COM-)
PANY OF CALIFORNIA, a cor-)
poration,)

Complainant,)

vs.)

RICHFIELD OIL COMPANY)
OF CALIFORNIA, a corporation,)

Defendant.)

SECURITY-FIRST NATIONAL)
BANK OF LOS ANGELES, a na-)
tional banking association, as trus-)
tee,)

Plaintiff,)

RICHFIELD OIL COMPANY)
OF CALIFORNIA, a corporation,)
and WILLIAM McDUFFIE, as)
Receiver of Richfield Oil Company)
of California, a corporation,)

Defendants.)

IN EQUITY
CONSOLIDATED
CAUSE
NO. S-125-J.

PETITION
FOR APPEAL.

UNIVERSAL CONSOLIDATED)
 OIL COMPANY, a California cor-)
 poration,)
 Intervenor.)
 _____)

TO THE HONORABLE WILLIAM P. JAMES,
 JUDGE OF THE DISTRICT COURT OF THE
 UNITED STATES, FOR THE SOUTHERN DIS-
 TRICT OF CALIFORNIA:

Universal Consolidated Oil Company, a corporation, intervenor herein, petitioner herein, considering itself aggrieved by that certain order, judgment and decree made and entered by the court in the above entitled cause on September 26, 1934, adjudicating each, all and sundry the exceptions filed to the Report of the Honorable William A. Bowen, Special Master in said cause, with reference to the bill in intervention of Universal Consolidated Oil Company, which report was filed on May 26, 1933, does hereby appeal from said order, judgment and decree to the United States Circuit Court of Appeals for the Ninth Circuit, for the reason specified in its assignment of errors, which is filed herewith, and pray that its appeal may be allowed and that a transcript of the record, proceedings and papers upon which said order, judgment and decree were based and made, duly authenticated, may be sent to the United States Circuit Court of Appeals for the Ninth Circuit, sitting at San Francisco in said Circuit, and your petitioners further pray that the proper order

touching the security to be required of petitioners to perfect their said appeal be made.

Dated at Los Angeles, California, this 26th day of December, 1934, in Open Court.

A. L. Weil

Le Roy M. Edwards

Solicitors for Petitioner above named.

810 So Flower St Los Angeles

It is ordered, on motion of Appellant, that the foregoing appeal be, and it is hereby allowed as prayed for, Cost Bond to be given by Appellant in the sum of \$1000.

Dated December 26, 1934.

Wm P. James

Judge of the above entitled court.

[Endorsed]: Filed Dec. 26, 1934. R. S. Zimmerman,
Clerk By L. Wayne Thomas, Deputy Clerk.

[TITLE OF COURT AND CAUSE.]

ASSIGNMENT OF ERRORS

Now come Universal Consolidated Oil Company, a California corporation, intervenor herein, petitioner and appellant in the above entitled action, and having prayed for the allowance of their appeal to the United States Circuit Court of Appeals for the Ninth Circuit from the order, judgment and decree of the above entitled United States District Court entered in said cause on September 26, 1934, adjudicating each, all and sundry the exceptions filed to the Report of Honorable William A. Bowen, Special Master in said cause, with reference to the bill in intervention of Universal Consolidated Oil Company, which report was filed on May 26, 1933, all as is more particularly set forth in the petition presented herewith, and respectfully represent and say that said order, judgment and decree is erroneous and unjust to said appellant in the following particulars, and respectfully present and file the following as the assignment of errors upon which it will rely in the prosecution of said appeal, to-wit:

1. The court erred in approving and confirming the Report of the Honorable William A. Bowen, Special Master in the above entitled cause, on the bill in intervention of Universal Consolidated Oil Company, which report was filed in the office of the Clerk of the above entitled court on May 26, 1933.

2. The court erred in approving and confirming the finding of fact and/or conclusions of law in said Report (Report p. 39, 40; also p. 83, line 4) that the prior lien of the Universal Consolidated Oil Company, intervenor, was

in the sum of \$403,993.92, or any sum less than \$1,183,148.28.

3. The court erred in approving and confirming the finding of fact and/or conclusions of law in said Report (Report p. 78, line 4) that no interest should be allowed Universal Consolidated Oil Company upon its claim.

4. The court erred in approving and confirming the finding of fact and/or conclusions of law in said Report (Report p. 83, line 4) that said intervenor was entitled to have a lien and trust imposed upon the following described properties, in the following amounts, which said properties are described in said Report, to-wit:

Parcel 1, "Franklin and Vermont Service Station" real property	\$ 492.60
Parcel 2, "Delaney Producing Properties", leaseholds	103,442.33
Parcels 3 & 4, Ten Storage tanks, Personal property	91,881.85
Parcel 5, "Mull Property". Real Property	500.00
Parcel 6, "Vapor Recovery Plant". Personal Property	34,332.84
Parcel 7, One Hundred Six Thousand (106,000) shares of Universal Stock, Certificates Nos. LX 26, 27, 28 & 32	162,719.30
Parcel 8, Five Thousand One Hundred (5,100) shares of Universal Stock, Certificates No. LX 31	10,625.00
TOTAL	\$403,993.92

5. That the court erred in approving and confirming the finding of fact and/or conclusion of law in said Report (Report p. 83, line 4) which failed to give, declare and enforce in favor of intervenor, Universal Consolidated Oil Company, a trust in the amounts specified below, and upon such right, title and interest as may appear to be vested in Richfield Oil Company of California, a corporation, and its receiver superior to any right, title, interest or lien of Security-First National Bank of Los Angeles, as trustee, under the bond or trust indenture sought to be foreclosed herein, in and to the following properties and parcels described in said Report, to-wit:

Parcel 1, "Franklin and Vermont Service Station" real property	\$ 8,500.00
Parcel 2, "Delaney Producing Properties", leaseholds	150,000.00
Parcels 3 & 4, Ten storage tanks, personal Property	\$183,207.57
Parcel 5, "Mull Property". Real Property	5,000.00
Parcel 6, "Vapor Recovery Plant". Personal Property	115,367.07
Parcel 7, One Hundred Six Thousand (106,000) shares of Universal Stock, Certificates LX 26, 27, 28 & 32	199,500.00
Parcel 8, Five Thousand One Hundred (5,100) shares of Universal Stock, Certificate LX 31	10,625.00
Parcel 9, Tankers. Larry Doheney and Pat Doheney & Richfield Marine Terminal	142,242.86
TOTAL	\$849,864.25

6. The court erred in approving and confirming the finding of facts and/or conclusion of law in said Report (Report p. 39, line 16 et seq.) limiting the recovery of intervenor to the low bank balance theory, as set forth in the Master's Report.

7. The court erred in approving and confirming the finding of fact and/or conclusion of law in said Report (Report p. 37, line 8) which denied to intervenor the right to consider the closing bank balance in the bank account of the Richfield Oil Company in establishing the amount of Richfield Oil Company's bank balance each day in connection with the tracing of the withdrawal of funds.

8. The court erred in approving and confirming the finding of fact and/or conclusion of law in said Report (Report p. 37, line 17 et seq.) which failed to hold and determine that intervenor was entitled to a prior lien on all properties acquired in whole or in part with commingled funds limited by the low bank balance of that commingled fund, which balance should be determined as being the bank balance existing at the end of each business day.

9. The court erred in approving and confirming the finding of fact and/or conclusion of law in said Report (Report p. 38, line 4) that in the tracing of trust funds the intervenor was limited to the low bank balances in the bank account of the Richfield Oil Company, resulting from the deduction of withdrawals for the day from the opening balance without crediting deposits for the day.

10. The court erred in not concluding and declaring that intervenor was entitled to a prior lien on all prop-

erties acquired by Richfield Oil Company in whole or in part with commingled funds, limited only by the low bank balance of said Richfield Oil Company on the closing of the bank at the end of each business day.

11. The court erred in approving and confirming the finding of fact and/or conclusion of law in said Report (Report p. 39, 40) that intervenor was limited in its recovery by the bank balances computed in accordance with the low bank balance at the beginning of each business day less all withdrawals from said bank account during said day, and without giving credit for deposits made during the day, all as set forth in the computations on pages 39 et seq. of said Master's Report.

12. The court erred in failing and declining to adjudicate, decide and determine that said intervenor is entitled to have a trust imposed upon the following parcels of property described in said Master's Report in the following amounts, to-wit:

Parcel 1.	"Franklin & Vermont Service Station".	\$ 8,500.00
Parcel 2.	"Delaney Producing Property".	150,000.00
Parcels 3 & 4.	Ten Storage Tanks	183,207.57
Parcel 5.	"Mull Property".	5,000.00
Parcel 6.	"Vapar Recovery Plant".	115,367.07
Parcel 7.	One Hundred Six Thousand (106,000) shares Universal Stock. Certificate LX 26, 27, 28 & 32	199,500.00

Parcel 8.	Five Thousand One Hundred (5,100) shares Universal Stock. Certificate LX 31	10,625.00
Parcel 9.	Tanker Larry Doheny) Tanker Pat Doheny) Richmond Marine Terminal)	142,242.86
TOTAL		<u>849,864.25</u>

13. The court erred in approving and confirming the finding of fact and/or conclusion of law in said Special Master's Report (Report p. 83, line 4) which holds that no reclamation, lien or other preference can be allowed intervenor on \$779,154.31 of its claim, and that as to said amount the claim of intervenor must be allowed only as an unsecured claim.

WHEREFORE, petitioner and appellant pray that such order, judgment and decree may be reversed, and for such other and further relief as the court may seem just and proper.

DATED this 26th day of December, 1934.

A. L. Weil
Le Roy M. Edwards

Attorneys for Petitioner and Appellant above named.

[Endorsed]: Filed Dec. 26, 1934 R. S. Zimmerman
Clerk By L. Wayne Thomas, Deputy Clerk

[TITLE OF COURT AND CAUSE.]

BOND ON APPEAL

(Order of September 26, 1934).

KNOW ALL MEN BY THE PRESENTS:

That the undersigned, HARTFORD ACCIDENT AND INDEMNITY COMPANY, a corporation organized and existing under the laws of the State of Connecticut, and duly qualified to do and to transact a general surety business in the State of California, and as well in the Southern United States Judicial District of the State of California, acknowledges itself to be indebted to the Security-First National Bank of Los Angeles, a corporation, The Chase National Bank of the City of New York, a national banking association, Bank of America, a corporation, Pan American Petroleum Company, a corporation, William C. McDuffie, as Receiver of Richfield Oil Company of California, a corporation, William C. McDuffie, as Receiver of Pan American Petroleum Company, a corporation, Richfield Oil Company of California, a corporation, The United States of America, The Republic Supply Company of California, a corporation, Cities Service Company, a corporation, M. W. Lowery, Henry S. McKee, O. C. Field and R. R. Templeton, (known and designated as Richfield Unsecured Creditors' Committee), Robert C. Adams, Thomas B. Eastland, Edward F. Hayes and Rich-

ard W. Millar (known and designated as Pan American Bondholders' Committee), G. Parker Toms, Robert C. Adams, F. S. Baer, Robert E. Hunter, Henry S. McKee and Richard W. Millar (known and designated as Richfield-Pan American Reorganization Committee), Security-First National Bank of Los Angeles, a national banking association, Pacific American Company, a corporation, American Company, a corporation, Manufacturers Trust Company of New York, a corporation, Citizens National Trust & Savings Bank of Los Angeles, a national banking association, First National Bank and Trust Company of Seattle, a national banking association, Continental Illinois Bank and Trust Company, a corporation, The First National Bank of Chicago, a national banking association, Chemical National Bank and Trust Company, a national banking association, and California Bank, a corporation, appellees in the above cause, jointly but not severally, in the sum of One Thousand and no/100 dollars (\$1000.00), conditioned that:

WHEREAS, on September 26, 1934, in the above entitled action in the above entitled court said court made and entered its order, judgment and decree adjudicating each, all and sundry the exceptions filed to the Report of the Honorable William A. Bowen, Special Master in said cause, with reference to the bill in intervention of Universal Consolidated Oil Company, which Report was filed on May 26, 1933, and the party appellant hereinafter named, has been allowed leave to appeal to the United

States Circuit Court of Appeals for the Ninth Circuit to reverse said order, judgment and decree.

Now if said party appellant, to-wit: Universal Consolidated Oil Company, a corporation, intervenor herein, shall prosecute its said appeal to effect and answer all costs, if it fails to make its plea good, then the above obligation to be void, else to remain in full force and virtue.

In no event shall liability or recovery on this bond exceed in the aggregate the sum of One Thousand and no/100 dollars (\$1000.00).

IN WITNESS WHEREOF, the said.....
has caused its name to be hereunto subscribed and its corporate seal to be affixed by its attorney in fact thereunto duly authorized this 26th day of December, 1934.

[Seal]

HARTFORD ACCIDENT AND
INDEMNITY COMPANY

By Dick W. Graves

Attorney in Fact.

Approved Dec. 26, 1934

Wm P. James

District Judge.

STATE OF CALIFORNIA,)
 County of Los Angeles,) ss.

On this 26th day of December, 1934, before me, OPAL GRAVES, a Notary Public in and for the said County of Los Angeles, State of California, residing therein, duly commissioned and sworn, personally appeared DICK W. GRAVES, known to me to be the Attorney-in-Fact, of the HARTFORD ACCIDENT AND INDEMNITY COMPANY, the Corporation that executed the within instrument, and acknowledged to me that he subscribed the name of the HARTFORD ACCIDENT AND INDEMNITY COMPANY thereto and his own name as Attorney-in-Fact.

[Seal]

Opal Graves

Notary Public, in and for the County of Los Angeles
 State of California

My Commission Expires June 18, 1938

[Endorsed]: Filed Dec. 26, 1934 R. S. Zimmerman,
 Clerk By L. Wayne Thomas, Deputy Clerk.

[TITLE OF COURT AND CAUSE.]

STIPULATION AS TO CONTENTS OF TRANSCRIPT OF RECORD UPON APPEALS FROM ORDERS DATED SEPTEMBER 17, 1934 AND SEPTEMBER 26, 1934.

WHEREAS, Security-First National Bank of Los Angeles, a national banking association, as Trustee, George Armsby, F. S. Baer, Harry J. Bauer, Stanton Griffis, Robert E. Hunter and Albert E. Van Court, as and constituting the Richfield Bondholders' Committee, have appealed to the United States Circuit Court of Appeals for the Ninth Circuit from the order and decree of the above entitled court made and entered September 17, 1934 (designated herein for convenience as "Appeal No. 1"); and have also appealed to said court from the order and decree made and entered September 26, 1934 (designated herein for convenience as "Appeal No. 2"); and

WHEREAS, Universal Consolidated Oil Company has appealed to said United States Circuit Court of Appeals from said order and decree made and entered September 26, 1934 (designated herein for convenience as "Appeal No. 3"); and

WHEREAS, said appellants in said appeals desire to consolidate the transcripts of the records in each of said appeals,

Now therefore IT IS HEREBY STIPULATED and AGREED by and between the undersigned solicitors for

appellants and appellees in the above mentioned appeals that a consolidated transcript of the record be prepared by the Clerk of the above entitled court and filed in the United States Circuit Court of Appeals for the Ninth Circuit, pursuant to the above mentioned appeals heretofore allowed herein, which consolidated transcript shall include the following pleadings, papers, exhibits and records and shall omit all other pleadings, papers, exhibits and records, to-wit:

1. Order of the Court dated September 17, 1934, approving and confirming the report of Special Master filed May 26, 1932;

2. Minute Entry of Order of Court of December 17, 1934, showing motion of Security-First National Bank of Los Angeles as Trustee, et al, appellants, for leave to appeal from Order mentioned in Item 1, supra;

3. Petition for Appeal in Appeal No. 1 from Order mentioned in Item 1, supra;

4. Assignment of Errors in Appeal No. 1 from Order mentioned in Item 1, supra;

5. Order allowing appeal in Appeal No. 1 from Order mentioned in Item 1, supra;

6. Bond on Appeal in Appeal No. 1 from Order mentioned in Item 1, supra;

7. Citation on Appeal in Appeal No. 1 from Order mentioned in Item 1, supra;

8. Return of Admission of Service in Appeal No. 1 of citation mentioned in Item 7, supra;
9. Order of the Court dated September 26, 1934, approving and confirming the reports of Special Master, filed May 26, 1933, upon the claim of Universal Consolidated Oil Company, and upon the bill in intervention filed by it;
10. Minute Entry of Order of Court of December 26, 1934, showing motion of Security-First National Bank of Los Angeles, as Trustee, et al, appellants, for leave to appeal from order mentioned in Item 9, supra;
11. Petition for Appeal in Appeal No. 2 from Order mentioned in Item 9, supra;
12. Assignment of Errors in Appeal No. 2 from Order mentioned in Item 9, supra;
13. Order allowing appeal in Appeal No. 2 from Order mentioned in Item 9, supra;
14. Bond on Appeal in Appeal No. 2 from Order mentioned in Item 9, supra;
15. Citation on Appeal in Appeal No. 2 from Order mentioned in Item 9, supra;
16. Return of Admission of Service in Appeal No. 2 of citation mentioned in Item 15, supra;
17. Petition for Appeal in Appeal No. 3 from Order mentioned in Item 9, supra;
18. Assignment of Errors in Appeal No. 3 from Order mentioned in Item 9, supra;

19. Order allowing appeal in Appeal No. 3 from Order mentioned in Item 9, supra;

20. Bond on Appeal in Appeal No. 3 from Order mentioned in Item 9, supra;

21. Citation on Appeal in Appeal No. 3 from Order mentioned in Item 9, supra;

22. Return of Admission of Service in Appeal No. 3 of citation mentioned in Item 2, supra;

23. Agreed statement of the case executed by the parties hereto and approved by the Court and now on file;

24. Copy of this Stipulation;

25. Certificate of the Clerk of the United States District Court for the Southern District, certifying to Transcript prepared by him in accordance with this Stipulation.

The parties stipulate by and through their Solicitors that if it be found by the Solicitors for any of the parties hereto, or by the Circuit Court of Appeals for the Ninth Circuit that this transcript of the record is insufficient for any reason, then a further supplemental transcript may be made upon due notice being given.

Dated this 15th day of March, 1935.

O'MELVENY, TULLER & MYERS,
900 Title Insurance Building,
Los Angeles, California

Clinton La Tourette

Solicitors for Security-First National Bank of Los Angeles, a National Banking Association, as Trustee.

BAUER, MACDONALD, SCHULTHEIS
& PETTIT

621 South Spring Street,
Los Angeles, California

Alexander Macdonald

Solicitors for Richfield Bondholders' Protective Com-
mittee.

CHANDLER, WRIGHT & WARD

631 Van Nuys Building,
Los Angeles, California

Leo S. Chandler

CALL & MURPHEY

514 Pacific Mutual Building
Los Angeles, California

By Alex W. Davis

Solicitors for Unsecured Creditors Protective Commit-
tee—Richfield Oil Company of California.

MUDGE, STERN, WILLIAMS &
TUCKER,

20 Pine Street,
New York, New York

FRESTON & FILES,

650 South Spring Street,
Los Angeles, California

Clarence M. Hanson

Solicitors for The Chase National Bank of the City of
New York.

MUDGE, STERN, WILLIAMS &
TUCKER,

20 Pine Street,
New York, New York.

FRESTON & FILES,
650 South Spring Street,
Los Angeles, California

Clarence M. Hanson

Solicitors for Bank of America, a corporation.

CLAYTON T. COCHRAN,
741 Richfield Building,
Los Angeles, California

Clayton T. Cochran

Solicitor for Pan American Petroleum Company a corporation.

GIBSON, DUNN & CRUTCHER,
634 South Spring Street,
Los Angeles, California

Homer D. Crotty

Solicitors for William C. McDuffie as Receiver for Pan American Petroleum Company.

MORTIMER A. KLINE,
Union Oil Building,
Los Angeles, California

Mortimer A. Kline

Special Solicitor for William C. McDuffie as Receiver of Pan American Petroleum Company.

WILLIAM J. De MARTINI,
306 Richfield Building,
Los Angeles, California

Wm. J. De Martini

Solicitor for Richfield Oil Company of California, a corporation.

ATLEE POMERENE,
H. J. CRAWFORD,
FRANK HARRISON,

Special Assistants to the Attorney General of the United States.

Union Trust Building,
Cleveland, Ohio

PEIRSON M. HALL,

United States Attorney.

508 Federal Building,
Los Angeles, California

JOHN R. LAYNG,

Special Assistant United States Attorney.

1018 Board of Trade Building,
Los Angeles, California

John R. Layng

Solicitors for United States of America.

CHANDLER, WRIGHT & WARD,

631 Van Nuys Building,
Los Angeles, California

Leo S. Chandler

Solicitors for The Republic Supply Company of California, a corporation.

HILL, MORGAN & BLEDSOE,

639 Roosevelt Building,
Los Angeles, California

ELVON MUSICK,

Subway Terminal Building,
Los Angeles, California

George Martinson

Solicitors for Cities Service Company, a corporation.

A. L. WEIL,

108 West Second Street,
Los Angeles, California

LeROY M. EDWARDS,

810 South Flower Street,
Los Angeles, California

By Martin J. Weil

Solicitors for Universal Consolidated Oil Company, a corporation.

COLIN C. IVES,

621 South Spring Street,
Los Angeles, California

CRAVATH, deGERSDORFF, SWAINE &
WOOD,

15 Broad Street,
New York, New York

Colin C. Ives

Solicitors for Robert C. Adams, Thomas B. Eastland,
Edward F. Hayes and Richard W. Millar (known
and designated as Pan American Bondholders' Com-
mittee)

BAUER, MACDONALD, SCHULTHEIS
& PETTIT,

621 South Spring Street,
Los Angeles, California

CRAVATH, deGERSDORFF, SWAINE &
WOOD,

15 Broad Street,
New York, New York

CHANDLER, WRIGHT & WARD,

631 Van Nuys Building,
Los Angeles, California

CALL & MURPHEY,

Pacific Mutual Building,
Los Angeles, California

Alexander Macdonald,

Alex W. Davis

Colin C. Ives,

Leo S. Chandler,

Solicitors for G. Parker Toms, Robert C. Adams, F. S. Baer, Robert E. Hunter, Henry S. McKee and Richard W. Millar (known and designated as Richfield-Pan American Reorganization Committee).

CALL & MURPHEY,

514 Pacific Mutual Building,
Los Angeles, California

Alex W. Davis

Solicitors for Security-First National Bank of Los Angeles, a national banking association, Pacific American Company, a corporation, American Company, a corporation, Manufacturers Trust Company of New York, a corporation, Citizens National Trust & Savings Bank of Los Angeles, a national banking association, First National Bank and Trust Company of Seattle, a national banking association, Continental Illinois Bank and Trust Company, a corporation, The First National Bank of Chicago, a national banking association, Chemical National Bank and Trust Company, a national banking association, and California Bank, a corporation.

GIBSON, DUNN & CRUTCHER,

634 South Spring Street,
Los Angeles, California

Homer D. Crotty

Solicitors for William C. McDuffie, as Receiver of Richfield Oil Company of California, a corporation

[Endorsed]: Filed Mar 16 1935 R. S. Zimmerman,
Clerk By Edmund L. Smith Deputy Clerk

[TITLE OF COURT AND CAUSE.]

CLERK'S CERTIFICATE.

I, R. S. Zimmerman, clerk of the United States District Court for the Southern District of California, do hereby certify the foregoing volume containing 285 pages, numbered from 1 to 285 inclusive, to be the Transcript of Record on Appeal in the above entitled cause, as printed by the appellant, and presented to me for comparison and certification, and that the same has been compared and corrected by me and contains a full, true and correct copy of the citation on appeal and return of service from order of September 17, 1934; citation and return of service from order of September 26, 1934; citation on cross-appeal and return of service from order of September 26, 1934; order dated September 17, 1934; minute entry of December 17, 1934; order of September 26, 1934; minute entry of December 26, 1934; agreed statement of the case; petition for appeal, assignment of errors, order allowing appeal and bond on appeal from order of September 17, 1934; petition for appeal, assignment of errors, order allowing appeal and bond on appeal from order of September 26, 1934; petition on cross-appeal and order allowing same; assignment of errors on cross-appeal; bond on cross-appeal and stipulation as to contents of transcript of record.

I DO FURTHER CERTIFY that the amount paid for printing the foregoing record on appeal is \$ and that said amount has been paid the printer by the appellant herein and a receipted bill is herewith enclosed, also that the fees of the Clerk for comparing, correcting and certifying the foregoing Record on Appeal amount to.....

and that said amount has been paid me by the appellant herein.

IN TESTIMONY WHEREOF, I have hereunto set my hand and affixed the Seal of the District Court of the United States of America, in and for the Southern District of California, Central Division, this..... day of March, in the year of Our Lord One Thousand Nine Hundred and Thirty-five and of our Independence the One Hundred and Fifty-ninth.

R. S. ZIMMERMAN,
Clerk of the District Court of the
United States of America, in
and for the Southern District
of California.

By

Deputy.



In the United States
Circuit Court of Appeals

For the Ninth Circuit.

The Republic Supply Company of
California, a corporation,

Complainant,

vs.

Richfield Oil Company of California,
a corporation,

Defendant.

Security-First National Bank of Los
Angeles, as Trustee, et al.,

Appellants and Cross-Appellees,

vs.

Universal Consolidated Oil Company,
a California corporation,

*Intervenor, Appellee and
Cross-Appellant,*

The Chase National Bank of the City
of New York, et al.,

Appellees.

BRIEF OF CROSS-APPELLANT UNIVERSAL
CONSOLIDATED OIL COMPANY.

A. L. WEIL,

Higgins Bldg., 108 W. 2d St., Los Angeles, Cal.

LE ROY M. EDWARDS,

810 So. Flower St., Los Angeles, Cal.,

Attorneys for Appellant.



TOPICAL INDEX.

	PAGE
Preliminary Statement.....	4
Statement of the Case.....	6
(a) The method of computing low balances adopted by the Special Master.....	11
Specifications of errors relied on by appellant.....	15
Summary of argument.....	15
Argument	16
I.	
The closing balances on a particular date should have been used by the Special Master in determining the amount of the trust lien.....	16
II.	
If the closing balances are not used, then at least the lowest posted balances should be used.....	24
Conclusion	36
Appendix "A." Table following page 36.	

TABLE OF AUTHORITIES CITED.

	PAGE
American Surety Co. v. Jackson, 24 Fed. (2d) 768.....	27
Arnold v. San Ramon, 184 Cal. 632.....	28, 29
Bank of America v. Calif. Bk., 218 Cal. 261.....	28
Brennan v. Tillinghast, 201 Fed. 609.....	16
Brown, In re, 193 Fed. 24.....	17, 18, 31
Central National Bank v. Connecticut Mutual Life Insurance Co., 104 U. S. 54, 26 L. Ed. 693.....	26
Civil Code, Sec. 3265e.....	29
Conqueror Trust Co. v. Fidelity & Deposit Co., 63 Fed. 2nd 833	36
First National Bank of Princeton v. Littlefield, 226 U. S. 110....	31
Florence Mining Co. v. Brown, 124 U. S. 385, 31 L. Ed. 424.....	28
Guggenhime & Co. v. Lamantia, 207 Cal. 96.....	29
Horigan Realty Co. v. First National Bank, 273 S. W. 773.....	19
Israel v. Woodruff, 299 Fed. 454.....	28
J. M. Acheson Co., In re, 170 Fed. 427.....	28
Kineon v. Bonsall, 185 N. Y. S. 694; 134 N. E. 598.....	28
Knatchbull v. Hallett, 13 Ch. Div. 696.....	16
Meyers v. Baylor University, 6 S. W. (2d) 393.....	27
National Bank v. Insurance Co., 104 U. S. 54, 26 L. Ed. 693.....	19
New York National Bank v. Massey, 192 U. S. 138, 48 L. Ed. 380	28
Note in 82 A. L. R. 46.....	16
Oatway, L. R. In re, 2 Ch. Div. 356.....	16
Pacat Finance Corp., In re, 27 Fed. (2d) 810.....	16
People v. Keller, 79 Cal. App. 612.....	31
Primeau v. Granfield, 184 Fed. 480.....	16
Schumacher v. Harriett, 52 Fed. (2nd) 817.....	32
Schuyler v. Littlefield, 232 U. S. 707, 58 L. Ed. 806.....	18
Smith v. Mottley, 150 Fed. 266.....	28
Sneider v. Bank of Italy, 184 Cal. 595.....	29
Spencer v. Pettit, 17 S. W. (2d) 1102.....	28

No. 7812.

In the United States
Circuit Court of Appeals
For the Ninth Circuit.

The Republic Supply Company of
California, a corporation,
Complainant,

vs.

Richfield Oil Company of California,
a corporation,
Defendant.

Security-First National Bank of Los
Angeles, as Trustee, et al.,
Appellants and Cross-Appellees,

vs.

Universal Consolidated Oil Company,
a California corporation,
*Intervenor, Appellee and
Cross-Appellant,*

The Chase National Bank of the City
of New York, et al.,
Appellees.

BRIEF OF CROSS-APPELLANT UNIVERSAL
CONSOLIDATED OIL COMPANY.

PRELIMINARY STATEMENT.

This proceeding to establish a prior lien upon certain assets in the hands of William C. McDuffie, as Receiver of the Richfield Oil Company of California,* was brought by Universal Consolidated Oil Company by means of a bill in intervention against said Receiver and the Security-First National Bank of Los Angeles, as Trustee, under the terms of the mortgage and trust indenture of Richfield dated May 1, 1929. The theory of the action is that Richfield, after acquiring control of the Board of Directors of Universal shortly prior to going into receivership, took and misappropriated \$1,625,000 of cash belonging to the latter company, without the knowledge or approval of Universal, and deposited same in Richfield's bank account with the Security Bank. These funds in part were subsequently invested by Richfield in certain assets which have passed into the hands of the Receiver, and which assets Universal claims are now held in trust for it. [Tr. pp. 67 to 82, incl.]

Answers of the Receiver and the Security Bank to said bill in intervention were duly filed, which answers in the main consisted of denials of the material allegations of the bill in intervention. [Tr. pp. 83 to 95, incl.]

The bill in intervention, together with the issues raised thereto by the answers, was referred for hearing to a Special Master, William A. Bowen, Esq., appointed by the District Court. [Tr. p. 64.] The matter was heard upon oral and documentary evidence, and thereafter the

*In this brief William C. McDuffie is referred to as Receiver; Richfield Oil Company of California is referred to as Richfield; Universal Consolidated Oil Company is referred to as Universal, and Security-First National Bank of Los Angeles is referred to as Security Bank. (All italics are ours unless otherwise noted.)

Special Master sustained Universal's contention that the transaction whereby the money was taken from Universal by Richfield was an actual misappropriation of funds by one standing in a fiduciary capacity, and was not, as contended by defendants, a bona fide loan; and found that the result of those misappropriations was to constitute Richfield a trustee for Universal, and the funds taken trust funds. He also found that Universal had succeeded in tracing its trust funds into specific parcels of property that passed into the hands of the Receiver, and that Universal was therefore entitled to prior liens upon those specified parcels in the hands of the Receiver in the total amount of \$403,993.92. Universal was awarded an unsecured claim in the amount of \$779,154.31, being the balance of the misappropriated money which it was held had not been sufficiently traced into specific property in the possession of Receiver. [Tr. pp. 109-110; 172; 205-206.] These findings of the Special Master were approved by the District Court in its decree, from which this appeal was taken. [Tr. pp. 42 to 44, incl.]

In this appeal Universal claims that it should have been awarded prior liens in an amount totaling \$849,864.25—it being claimed that Universal traced this amount of its money into specific property now in the possession of the Receiver. The difference in the amount awarded Universal by the Court and Special Master (\$403,993.92) and the amount which Universal claims it should have been awarded (\$849,864.25), arises entirely from the erroneous method adopted in determining the lowest bank balances reached by the account of Richfield in the Security Bank. In that account Richfield deposited the funds taken from Universal and there commingled them with its own funds. If the Court and Special Master

were incorrect in the method employed by them in determining these bank balances, then Universal is entitled to liens in excess of the ones actually awarded it. This brief will be devoted entirely to a discussion of that one question, and, necessarily, it is assumed in this brief that all other points were correctly decided in favor of Universal.

STATEMENT OF THE CASE.

While one of the issues before the Special Master was the question of whether or not the financial transactions between Universal and Richfield gave rise to a trust relation—and the report of the Special Master thereon is in the affirmative—it has now been conceded by all parties that the taking of Universal funds was a misappropriation resulting in making Richfield the trustee of a constructive trust for Universal, as beneficiary. [Tr. p. 97.] As a result of this stipulation, it becomes unnecessary to present in detail the numerous schemes, machinations and financial trickery practiced by Richfield upon Universal. However, we believe it advisable to give a short history of the transactions by which Richfield acquired control of Universal, and misappropriated \$1,625,000.00 from that company.

Universal was a small, independent oil company engaged in the business of producing oil in California, but not owning any refineries, pipelines or marketing business. Universal's stock was owned by the general public, the control, however, being vested in William H. Crocker. [Tr. p. 118.]

In the summer of 1929 Universal had accumulated about \$1,700,000.00 in excess cash. Most of this money had been placed in the call loan market. This large sum

of ready cash was the magnet which drew the attention of the Richfield's "financiers." In discussions between the various men in control of Richfield, the cash which Universal had on hand was favorably commented upon, and the fact was also mentioned that if Richfield acquired control of Universal, it could advance some of that cash to itself. [Tr. p. 118.] From that time on the rape of Universal was quickly planned and consummated.

It was planned that Joe Toplitzky, a Director of Richfield, and one of its dominant factors, should form a syndicate and get control of Universal by contracting to purchase the Crocker holdings (167,000 shares). On August 13, 1929, a contract was made by Toplitzky to acquire the Crocker stock, the contract giving Toplitzky the right to nominate a majority of the Board of Directors of Universal immediately. [Tr. p. 119.] Richfield was to buy 47,000 shares of this stock, which it did on September 27, 1929. Three days later Talbot, Chairman of Richfield's Board of Directors, went in as President and Director of Universal; and Fuller, President of Richfield, Tucker, a Director of Richfield, and Melvin, Vice President and General Counsel of Richfield, went on the Board of Directors of Universal. From then on Richfield controlled and dominated Universal [Tr. p. 121], although Richfield's stock interest in Universal only amounted at that time to 13 per cent of the outstanding shares. Ultimately Richfield's holdings in Universal were increased to 52 per cent. [Tr. p. 120.]

Immediately after getting control of the Board of Directors and executive offices of Universal, Richfield men were placed in all responsible positions in the corporation, and employees of Richfield were given authority to sign Universal checks. [Tr. pp. 121 and 122.]

Beginning with October of 1929, Universal, under the domination of Richfield, and at the direction of Talbot, recalled its surplus cash of \$1,700,000.00 from the call loan market and from another loan that had been made. The monies were placed in depositories selected by Talbot. [Tr. p. 125.] Then started the raid on Universal. [Tr. p. 126.]

On November 13, 1929, Richfield took \$750,000.00 of Universal's available cash. Other withdrawals occurred periodically from that day forward until all of Universal's excess cash was gone. [Tr. p. 126.] The policy of withdrawing Universal funds from the call loan market and thereafter turning Universal funds over to Richfield was determined by Talbot (Chairman of the Board of Richfield), and Talbot's orders were carried into execution under the supervision of McKee (Assistant to Talbot in the Richfield organization). [Tr. p. 125.]

All of these withdrawals were by checks payable to Richfield, which checks were deposited by Richfield in its general bank account in the Security Bank at Los Angeles.

No note was ever given to Universal by Richfield for any of the moneys represented by the aforesaid checks of Universal, nor was any security given in connection therewith. [Tr. p. 127.] No resolution was ever adopted by the Universal Board of Directors authorizing or ratifying the taking of the funds by Richfield, nor is there any resolution in the minutes of Universal from September 30, 1929, to the time of the appointment of the Richfield Receiver on January 15, 1931, authorizing any loans to Richfield or authorizing any officer of Universal or anyone else to loan any of the Universal money to anybody. [Tr. p. 127.]

None of the directors other than those connected with Richfield were ever advised of the taking of these monies, nor were the takings ever disclosed to the stockholders of Universal, despite efforts made by individual stockholders to secure information as to the financial position of the company. In fact, Richfield and its officers did everything possible to conceal the facts of the misappropriation from everyone other than those connected with the Richfield organization. No mention of the takings appeared in the annual report to the stockholders of Universal issued over the signature of Talbot. [Tr. pp. 136 to 139, incl.]

When a stockholders' meeting of Universal was to be held on April 15, 1930, it became apparent to the Richfield management that the cash position of Universal would have to be bolstered in order to avoid questions from minority stockholders. To conceal the circumstances surrounding these misappropriations, Richfield, prior to the meeting and on the morning of April 15, 1930, deposited in Universal's bank account, \$600,000.00 so that the cash on hand would approximate the sum shown in the annual report. As soon as the stockholders' meeting was over the \$600,000.00 was returned to Richfield. [Tr. pp. 135, 136.]

By the shifting of these funds from Richfield to the Universal account, and back again when the necessity was gone; by concealment of the transfers, and by false financial statements, Richfield was able to perpetrate and conceal, until the receivership, this misappropriation of Universal funds.

Many other details of this financial juggling are set forth in the Master's Report. [Tr. pp. 118 to 142. incl.]

We now turn to the evidence that was introduced for the purpose of tracing the money that was misappropriated by Richfield into the bank account of that corporation, and from there into various properties which were purchased and paid for in whole or in part by funds from that account.

All the facts in regard to the actual deposit of Universal's monies and actual withdrawals of the commingled funds are agreed upon. It is admitted that this money was in Universal's bank accounts, and that it was drawn out on Universal checks payable to Richfield on the following dates and in the amounts set forth:

<u>Date</u>	<u>Amount</u>
Nov. 13, 1929	\$350,000.00
Nov. 13, 1929	400,000.00
Jan. 20, 1930	200,000.00
Feb. 15, 1930	250,000.00
Feb. 15, 1930	250,000.00
Feb. 25, 1930	100,000.00
Feb. 27, 1930	100,000.00
June 6, 1930	75,000.00

[Tr. p. 126.]

Two days after February 15, 1930, Richfield returned \$100,000.00 of this money to Universal. [Tr. p. 126.]

As before noted, all of the money misappropriated by Richfield from Universal went into a checking account maintained by Richfield in the Security Bank, and this trust money was commingled with other funds belonging to Richfield in that account. [Tr. pp. 97, 98.]

At the close of business on January 8, 1931, which was a week before the appointment of the Receiver, Richfield

had entirely used up the funds in this commingled account, and on that date there existed for the first time an overdraft of \$18,080.18. Consequently Universal cannot go beyond this date in its tracing. [Tr. p. 98.]

All of the property and assets here involved, including the additional property which Universal claims was purchased with trust funds, were paid for by checks issued out of this commingled bank account maintained by Richfield. The amounts of these checks, the dates on which they passed through the Security Bank, and the property that they paid for, all appear in columns 1 and 3 of Appendix A attached to this brief, and are also set forth in Schedule A on page 102 of the transcript. [Tr. pp. 102-105, columns 1 and 6.]

Since the monies used by Richfield that belonged to Universal were trust funds, and since such money was traced into the Richfield commingled bank account, and since with such commingled funds Richfield purchased various assets on which a trust was impressed by the Special Master, the problem on this phase of the case deals with the question of the method used in tracing the trust funds. Universal, in tracing its funds, was of course limited in such tracing to the lowest intermediate balance that existed in the Richfield bank account at the time of the purchase of these particular assets.

(a) THE METHOD OF COMPUTING LOW BALANCES
ADOPTED BY THE SPECIAL MASTER.

The Special Master has detailed the various steps by which the funds were traced by Universal into the property purchased by Richfield. This method may be summarized as follows:

After the first deposit of the trust money, the lowest bank balance was ascertained between the time of this deposit and the first payment on property from the commingled bank account. Thereupon a trust was enforced upon the property for the amount of the payment, but the amount of the trust lien was limited to whichever one of the following sums was the lower; the said lowest bank balance or the said first deposit. If this purchase of the first piece of property did not exhaust the amount of the first deposit, then the trust was to be continued as to the unexhausted balance on subsequent purchases of property. If the trust amount was not entirely consumed by the applications on these purchases of property then the balance of said first deposit, limited by the lowest balance, would be carried over as a credit to Universal to the time of the second deposit of Universal funds. [Tr. pp. 145 to 147, incl.]

The practical application of the foregoing method will, we believe, be clarified by an illustration:

Suppose, for example, that Richfield, on February 1st, had deposited in its account in the Security Bank \$2,000.00 which it held in trust for Universal. At that time its bank balance in the Security Bank was \$3,000.00. Between that date and February 3rd, the balance always remained above \$2,000.00, but Richfield paid out no money for specific properties. On February 3rd the balance of Richfield's account in the Security Bank fell to \$1,000.00, but never fell below \$1,000.00. The balance was subsequently increased by additional deposits of Richfield funds, and on February 6th Richfield purchased a parcel of property for \$750.00. On February 7th purchased another parcel of property for \$750.00, or a total of \$1500.00 for the two pieces. Applying the foregoing method, we

see that Universal's right to trace its funds into the specific parcels of property is limited by the \$1,000.00 low balance reached by the Richfield account on February 3rd. It is entitled to a lien for the sum of \$750.00 upon the parcel purchased on February 6th. However, its lien upon the parcel purchased on February 7th is limited to \$250.00, as that is the balance of Universal funds remaining in the Richfield account.

If we change the facts slightly, and assume that the second parcel of property purchased on February 7th cost but \$150.00, then Universal would have a lien on the parcel purchased February 6th to the amount of \$750.00, and on the parcel purchased February 7th to the amount of \$150.00. This would leave Universal with a balance of \$100.00 unexpended for property which would be carried over to the next deposit of Universal's funds, assuming, of course, that the low balance thereafter in the account and up to the time of the next deposit was not less than \$100.00.

The crucial question here involved is the proper method of determining this lowest balance. Three different methods might be used in making the calculations. These are set forth by the Special Master in his report [Tr. p. 147], and are briefly as follows:

1. By taking the lowest daily closing balance on the bank's record. This figure was arrived at by taking the opening balance of the same day, adding thereto all deposits on that day, and charging against the total all the

withdrawals for the day. This classification appears in column 3 of Schedule A. [Tr. p. 102.]

2. By taking the lowest posted balance on the books of the bank on a particular date. This is determined by taking the opening balances of the day and by adding thereto such deposits and deducting such withdrawals as were posted by the bank's bookkeeper at that particular time of the day. This method appears in column 4, Schedule A. [Tr. p. 102.]

3. By taking the opening balance of the particular day, deducting therefrom all of the withdrawals made on that day, and *without* crediting to the account any deposits of the day. This method appears in column 5 of Schedule A [Tr. p. 102], and is the one used by the Special Master in determining the low balances.

It is the contention of Universal that the Special Master should have used the lowest daily closing balances (No. 1 *supra*) in order to determine the correct amount of Universal's trust lien, or, *at least*, the Special Master should have used the lowest daily posted balances, (No. 2 *supra*).

Had the Special Master used the lowest posted balances (No. 2, *supra*), the trust liens awarded to Universal would have been the sum of \$664,241.54; and had the Special Master adopted the lowest daily closing balances (No. 1, *supra*), the amount awarded to Universal would have totaled \$849,864.25.

For the convenience of the court we have set forth in Appendix A, attached to this brief, a tabulation showing the amounts of the liens under each of the three methods hereinbefore discussed.

ASSIGNMENTS OF ERRORS RELIED ON BY APPELLANT.

District Court erred in approving and confirming finding of fact and/or conclusion of law of the Special Master that said intervenor was entitled only to the amount imposed upon certain designated parcels, to-wit: Parcels 7 and 8, inclusive, in the total sum of \$403,993.92. [Assignment of Errors 2, 4; Tr. pp. 266, 267.]

District Court erred in approving and confirming finding of fact and/or conclusion of law of said Special Master limiting the recovery of Universal to the pro rata balance theory adopted by said Special Master. [Assignment of Errors 6, 9, 11; Tr. pp. 268, 269.]

District Court erred in failing to decree and award in favor of Universal a trust on Parcels 1 to 9, for the aggregate amount of \$849,864.25. [Assignment of Errors 5, 12, 13; Tr. pp. 268, 270, 271.]

District Court erred in failing to allow interest on the trust based upon the closing bank balance in the account of Richfield. [Assignment of Errors 7, 8, 10, 11; Tr. pp. 268, 269.]

SUMMARY OF ARGUMENT.

It is our purpose to show, first, that the lowest closing bank balances were the proper balances to be used in determining the amount of the trust lien awarded Universal; secondly, that the lowest daily posted balances should have been used as a very minimum in determining the amount of the trust.

ARGUMENT.

I.

The Closing Balances on a Particular Date Should Have Been Used by the Special Master in Determining the Amount of the Trust Lien.

Since the stipulation of the parties in this appeal proves the misappropriation of funds, and proves that Richfield was made the trustee thereof; since the monies so misappropriated went into the Richfield bank account; since Richfield purchased certain properties with checks on this commingled bank account between the date of the first deposit of misappropriated funds and the depletion of the account, there is no question but that Universal is entitled to a trust lien on the properties purchased, governed solely by the lowest intermediate balances in the bank account.

These underlying principles have been announced in the leading cases of *Knatchbull v. Hallett*, 13 Ch. Div. 696 (1879), and *In re Oatway*, L. R. (1903), 2 Ch. Div. 356, which cases have been approved time after time in our Federal courts.

In re Pacat Finance Corp., 27 Fed. (2d) 810 (C. C. A. 2nd);

Brennan v. Tillinghast, 201 Fed. 609 (C. C. A. 6th);

Primeau v. Granfield, 184 Fed. 480 (D. Ct. N. Y.).

See, also:

Note in 82 A. L. R. 46.

In determining the amount of these bank balances the Special Master used the method which cut down the

y Universal to the lowest possible point—the t unfavorable to Universal. The Special Mas- king out his method, took the amount of money k account on the morning of a particular day, ed therefrom all of the withdrawals of that *without giving credit to the deposits made on that* file this method has done partial equity to the Universal, yet it has not done complete equity. as insured Richfield, the wrondoer, against any recovery, yet this has been accomplished at the Universal, the innocent party.

s method of computation is manifestly unfair al is evident at first blush, for it presumes that withdrawals of the day were made *prior* to any sits of that day. Such method is as unreason- the converse method were used, namely, that deposits of the day were added to the opening hout deducting the withdrawals therefrom.

be remembered that the only balance, which is to be a *true* bank balance, is the balance at the day when all withdrawals have been charged account and all deposits have been credited to t. Since, in ordinary business practices, the ances of the day are accepted as the proper f determining balances, and since they are the balances, it seems self-evident that these bal- ld be used.

not unmindful of the statement of the Circuit ne case of *In re Brown*, 193 Fed. 24 (C. C. A. e effect that opening and closing balances were nt in that case, as there might have been with- rring the day that would have completely wiped

out the balance. But that case involved quite a few claimants, who were in an identical position, so that a recovery by one defrauded person affected the recovery of others who were defrauded in like manner. In the instant case, no other person is in the position of Universal; and no equity is present that is equal to or higher than Universal's.

Furthermore, in the *Brown* case, 193 Fed. 24, the facts showed that a certification of a check in a large amount completely depleted the account—thereby dissipating all claims to any trust funds, even if they were in the account. No question of certification is present in the instant case.

It must also be noted that the Circuit Court in that case takes cognizance of deposits in the account, saying:

“It might very well be that on any one day checks were presented which exhausted the morning balance *and its accretions*, in which event these moneys would have been dissipated.” (193 F. 26.)

Such reference to accretions could only mean deposits, as it is difficult to understand how else the account could be augmented.

We note that the Supreme Court, in passing on the case of *Schuyler v. Littlefield*, 232 U. S. 707, 58 L. Ed. 806 (a companion case to *In re Brown, supra*), mentions the condition of the account at the close of a particular day:

“If the trust fund of \$9,600.00 was included in the check for \$266,600.00, then it was dissipated except to the extent of \$6,180.17, which was the sum left to Brown & Company's credit at the *close of business* on August 24th. And inasmuch as all of

balance was paid out early the next day, the fund was thereby wholly dissipated so far as the bank account was concerned." (58 L. Ed. 808.)

The presumption prevails when Richfield withdrew from the commingled account and dissipated same, that the dissipated funds were from Richfield's own pocket and not from the trust funds. *National Bank v. Williams*, 104 U. S. 54, 26 L. Ed. 693. Logically, in the absence of force of the same presumption, the amount of the withdrawals should be charged against the amount of the deposits on a particular date. The withdrawals thus made must be first offset against the deposits of the same date. The principle of equity in this case would warrant the Master in utterly disregarding the deposits

in the case of *Horigan Realty Co. v. First National Bank*, 273 S. W. 773, there is involved a question of the commingling of certain funds in the account of the bank. Flynn was the secretary and treasurer of the plaintiff corporation and, in connection with the purchase of a piece of property owned by the plaintiff, Flynn deposited \$5,000.00 in Liberty bonds. These bonds were purchased by Flynn, but instead of the money going into the account of the plaintiff, Flynn deposited the amount in his personal account. Flynn was indebted to the bank on some notes, and shortly after the death of the plaintiff the bank charged the balance in the account, including these notes. The particular account involved, in addition to the deposit from the Liberty bonds, other

deposits and withdrawals. In speaking of this matter the court said:

“But we think the money, received from the sale of the bonds, and deposited by Flynn in the bank, may be traced and located in the hands of the bank at the date of Flynn’s death. Under like circumstances, it has been held that the depositor must be considered to have drawn out his own money in preference to the trust fund. *National Bank v. Insurance Co.*, 104 U. S. 54, 68, 26 L. Ed. 693. Applying this rule to the case at bar, we must presume Flynn first withdrew his own money from the bank before taking out any which belonged to the trust fund, and that *whatever deposits he made, after depositing the trust fund, were withdrawn before he drew upon the trust fund* or any part thereof which remained at the time of the withdrawals. Judgment was rendered by the court for the least amount that Flynn had to his credit between the time of the deposit of the trust fund and the time of his death. Under the rules above referred to, this was proper.” (p. 776.)

The case was reversed on other grounds.

Bearing in mind that every equity in this case should be in favor of Universal, and bearing in mind that the fraudulent practices of Richfield will only result in an unjust enrichment by the general creditors, at the expense of Universal, unless the trust is imposed to the maximum extent permitted by law, it is submitted that this court should adopt as the proper method of determining low balances the one founded on the closing bank balances. Even with all the aid afforded by this method, Universal will still not be able to recover its money one

cent, and Universal will still have a claim
 insured general creditor of close to \$300,000.00.
 amount of the liens to which Universal is entitled
 the lowest daily closing balances is as follows:
 y to Schedule A, Tr. p. 102, and applying the
 g balance to the first taking of Universal
 e: \$750,000, we find that the low occurred on
 3, 1929, when the account fell to \$272,704.61.
 limits the amount of the lien to that amount
 a the following properties:

Property	\$ 50,000.00
cks, Rioco refinery	44,540.00
ion, Franklin and Vermont,	
eles	500.00
akee	35,421.75
Doheny)	
oheny)	
and marine facilities, Richmond)	
)	142,242.86
	<hr/>
Total	\$272,704.61

the next \$200,000 taken on January 20, 1930,
 ced into assets purchased by Richfield for the
 nces were always greater than this sum until
 February. Universal is then entitled to the
 liens:

amento distributing plant	\$ 500.00
res Universal stock, Delaney prop-	199,500.00
	<hr/>
Total	\$200,000.00

The liens resulting from the next takings are not quite as simple to explain because of the existence of successively lower balances on February 25, 1930, and on March 8, 1930. The closing balance of \$252,760.24 on February 25, 1930, limits the tracing of the \$500,000 taken in the ten days prior to that date to that sum. No property was purchased by Richfield between February 15th and February 25th. Another \$100,000 was taken by Richfield on February 27, 1930, so that thereafter \$352,760.24 could be traced into property bought. This was traced into some property paid for during the course of the next week, but a low balance of \$209,201.80 on March 8th served as a further limitation of the tracings. Summarizing the liens Universal would be entitled to during this period we find that they would be on the following property:

Watson refinery vapor recovery plant	\$34,332.84	
Rioco refinery storage tanks	48,000.00	
5100 shares Universal stock	10,625.00	92,957.84
	<hr/>	
Delaney property	50,000.00	
Service station, Franklin and Vermont, Los Angeles	7,500.00	
Watson refinery vapor recovery plant	34,332.43	
Rioco refinery storage tanks	50,000.00	
Delaney property	50,000.00	
Service station, Franklin and Vermont, Los Angeles	500.00	

Land, Sacramento distributing plant	4,500.00	
Watson refinery vapor recovery plant	12,369.37	209,201.80
	<hr/>	
Total		<hr/> \$302,159.64

The low balance at no time fell below the sum of \$75,000 taken on June 6, 1930. That sum is a lien on the following properties:

Watson refinery vapor plant	\$34,332.43
Rioco refinery storage tanks	40,667.57
	<hr/>
Total	\$75,000.00

Cumulating the investments in the several properties, Universal is entitled to liens, based on the lowest daily closing balances, on the several properties for the following amounts:

Delaney producing property	\$150,000.00
Rioco refinery storage tanks	183,207.57
Watson refinery vapor recovery plant	115,367.07
106,000 shares of Universal stock, Certificates LX26, 27, 28, 32	199,500.00
5100 shares of Universal stock, Certificate LX31	10,625.00
Tanker Kekoskee	35,421.75
Service station, Franklin and Vermont, Los Angeles	8,500.00
Land, Sacramento distributing plant	5,000.00

Tanker Larry Doheny)	
Tanker Pat Doheny)	
Richmond marine terminal)	142,242.86
		<hr/>
Total		\$849,864.25

A full summary of all the data herein set out, together with dates, appears in Appendix A attached to this brief.

II.

If the Closing Balances Are Not Used, Then at Least the Lowest Posted Balances Should Be Used.

Without waiving our claim that the closing balances should be used, we now turn to a discussion of the effect of using the lowest posted balances. The nearest approach to a determination of the *exact* order in which deposits were made and checks were withdrawn appears in the lowest posted balances kept by the bank. While it was possible that at the time of the posting other checks might have been in the bank which had not been charged against the account, and other deposits might have been in the bank which had not been credited to the account, yet *no* evidence was produced by the Security Bank which showed these conditions to exist.

In the very nature of the present complexities of the banking business (unless the functions of the bank were stopped and time were taken out to make an exact balance), this is the only means that anyone can use to determine the balance of the account at any particular time of a day. This is the balance that the bank would quote to anyone inquiring what the balance of the account was at that particular moment.

According to the testimony, the books of the Security Bank are kept on bookkeeping machines. To enable them to keep up on their work the bookkeepers are not required to wait until the end of a day before they post checks to an account. Checks that come from the clearing house on the first clearing are given to them as soon as they are received, which is shortly after 8:15 in the morning. The same procedure is followed on the checks received in the second clearing, at 11:15 in the morning. [Tr. p. 99.]

Checks which come in over the counter are given to the bookkeepers periodically throughout the day, commencing at approximately 10:30 in the morning. Immediately upon receipt of the checks they are assorted by accounts and the task of posting them begins. Each time a group of checks or deposits, or both, is posted upon the ledger sheet of a particular account the bookkeeper, before he can remove the ledger sheet from the bookkeeping machine, must strike a balance for the account. While the bookkeepers are not required to follow any set rule and may post the checks in any order they desire, is it not logical to assume that checks are posted in approximately the order in which they are presented?

It is to be remembered that the Security Bank, in the course of a day's work, would post the balances in the Richfield account from three to eight times a day. [Tr. p. 99.] With this frequent number of postings, it is inconceivable that any large amount in checks, or any large amount in deposits would remain unposted at the bank for anything more than a very short fraction of the day. Nor, for that matter, is it conceivable that a

check presented or a deposit made toward the close of a day's business would appear on the books at the same time or ahead of checks presented to the bank at the time of the first morning clearing.

These posted balances, in the very nature of things, were as close to the true balances at the particular times as the Security Bank could make it. Unless the Security Bank can show that these posted balances were actually false, we submit that this court *must* accept the evidence and assume they were correct. It certainly is not enough for the Security Bank to come into court and attempt to impeach the records by saying they *might* have been incorrect. Particularly is this so when the very records are kept under the sole direction of the Security Bank. It should not be permitted to take advantage of the situation, and, at least, the burden would be on the Security Bank, rather than on Universal, at this stage of the proceedings to disprove the correctness of the posted balances.

In a headnote, written by the court, to the case of *Central National Bank v. Connecticut Mutual Life Insurance Co.*, 104 U. S. 54, 26 L. Ed. 693, it is there stated:

“That, so long as trust property can be traced and followed into other property into which it has been converted, the latter remains subject to the trust, and that if a man mixes trust funds with his own, the whole will be treated as the trust property, except so far as *he may be able to distinguish what is his own*, are established doctrines of equity and apply in every case of a trust relation, and to moneys deposited in a bank account, and the debt thereby created, as well as to every other description of property.” (Headnote 3.)

In the case of *American Surety Co. v. Jackson*, 24 Fed. (2d) 768 (C. C. A. 9), Judge Rudkin said:

“It will thus be seen that the rule itself rests largely on a legal fiction. But if there is a presumption that trust funds have not been wrongfully misapplied or criminally used by the officers of the bank, as held by this court in the Spokane County case, *supra*, and such a presumption no doubt obtains, it would seem to follow as a necessary corollary that *the burden was on the bank* or its successor in interest to prove that the trust funds or some part of them were in fact wrongfully misappropriated or criminally used by the bank. This presumption in nowise conflicts with the rule that in the end the claimant must trace the funds and establish his claim thereto by clear and satisfactory proof as against the receiver who represents all creditors.” (P. 770.)

Again, in *Meyers v. Baylor University*, 6 S. W. (2d) 393 (Tex.), the rule is thus given:

“It is quite true that the burden of proof was upon plaintiff to establish the trust, but, when proof of the fiduciary relationship of the parties was made, the betrayal of the trust, and probable amount of the embezzlement shown, a *prima facie* case was presented, and *the burden was then on Meyers to show*, if he could, that his money, and not that of the plaintiff, paid for the properties in whole or in part.

Meyers was in possession of the exact facts, and it was his duty to reveal the entire truth. As he did not testify, and made no explanation of this matter, every intendment is against him." (P. 394.)

See, also:

- Israel v. Woodruff*, 299 Fed. 454 (C. C. A. 2);
In re J. M. Acheson Co., 170 Fed. 427 (C. C. A. 9);
Smith v. Mottley, 150 Fed. 266 (C. C. A. 6);
Kineon v. Bonsall, 185 N. Y. S. 694; aff. 134 N. E. 598;
Spencer v. Pettit, 17 S. W. (2d) 1102 (Tex.).

In the absence of any direct and positive testimony that they were incorrect, it is the contention of this appellant that the posted balances appearing on the bank's books during the course of a day represent with reasonable certainty the fluctuations of that account during the day, and show with a sufficient degree of accuracy that the balance during the course of the day did not fall below the lowest of those fluctuations.

Further support is given to appellant's claim when the nature of the relationship between a bank and its depositor is considered. There is no dissent from the rule that that relationship is one of debtor and creditor.

See:

- New York National Bank v. Massey*, 192 U. S. 138, 48 L. Ed. 380;
Florence Mining Co. v. Brown, 124 U. S. 385, 31 L. Ed. 424;
Arnold v. San Ramon, 184 Cal. 632;
Bank of America v. Calif. Bk., 218 Cal. 261.

Consequently, when a deposit is made to an account and that deposit is placed on the bank's books to the credit of the depositor, that deposit becomes a fund owed by the bank to the depositor. Until such time as an offset is made against the account, that fund remains intact. It is not depleted until such time as a check is presented, paid, and *charged* against the account upon the books, for a check is not an assignment of the funds in a bank.

See:

Civil Code, Calif., Sec. 3265e;

Sneider v. Bank of Italy, 184 Cal. 595;

Guggenlime & Co. v. Lamantia, 207 Cal. 96;

Arnold v. San Ramon, 184 Cal. 632.

An examination of the procedure followed by the bank in connection with checks coming to it from the clearing house, which, of course, is the vehicle by which most checks come to a bank, must make it apparent that checks so delivered do not deplete the account of the depositor until such time as they are posted to his account. These checks are received from the clearing house at 8:15 and 11:15 in the morning. They need not be posted and paid, or refused, until 2:30 in the afternoon of the same day, although they are given to the bookkeepers immediately. Consequently, if a check for \$100 was presented at the window and paid during the course of a morning, payment on another \$100 check against the same account, which latter check came from the clearing house at 8:15, would be refused if the payment of the former check left insufficient funds to cover the payment of the second. [Tr. p. 101.] Obviously it could not be said

that the check which came into the bank first from the clearing house, but was not posted in the ledger, depleted the account of the depositor. For payment upon it was refused because of the fact that it was to be posted after a check presented at the window.

Another example to prove definitely that posting in the ledger, rather than time of presentment, is what determines whether the account is depleted, occurs in the case of two \$100 checks coming to the bank in the morning's clearing at a time when the account upon which they were drawn contained only \$100. Under those circumstances, payment might be refused on either check, but it is quite apparent that the one that would be accepted is the one posted first upon the ledger account of the depositor. [Tr. p. 100.] Thus we see that, except in the case of certified checks, with which we are not concerned at all in the instant case, the factor controlling the bank in its determination of whether or not there are sufficient funds in the bank to pay the checks drawn, is the posted balances of the ledger. Although there may be many checks upon the bookkeeper's desk awaiting posting, the order in which they are actually posted to the account determines which shall be paid and, consequently, determines whether or not the fund that goes to make up the depositor's account has actually been depleted.

It is thus apparent that the crucial moment in determining when the balance is affected would be at the time that the check was actually posted to the account. Until such posting, the check manifestly would bear no different relation to the balance in the bank account than would an unpaid demand note issued by Richfield to the Security Bank and payable to the latter. The bank is a creditor

of the depositor to the extent of the loan, while at the same time it is a debtor to the depositor to the extent of his deposit. Although the bank may demand payment of the loan at any time, and may deduct the amount of the loan from the depositor's account, one could hardly say that the depositor's account was depleted to the extent of the loan until such time as that offset was *actually* made upon the ledger.

This position is reinforced by the case of *In re Brown*, 193 Fed. Rep. 24, affirmed by the Supreme Court under the title of *First National Bank of Princeton v. Littlefield*, 226 U. S. 110. On page 27, the Circuit Court says:

“We are clearly of the opinion that when the question is as to the disposition of a fund in a bank account, *the time when certification is signed and noted by the bank is the significant time*; it is then that the credit items which make up the balance of account are segregated by the bank as against the obligation assumed by certification.” (193 Fed 27.)

See, also:

People v. Keller, 79 Cal. App. 612, 615, where it is said:

“The acceptance of the check by the Santa Ana Bank, the surrender of the instrument to it, the payment of the money to the forwarding bank and *the entry of the transaction upon the books* of the Santa Ana Bank constituted a segregation or separation of the amount of dollars expressed in the check from the general mass of money in the bank as the portion owing by it to appellant's principal.”

Modern banking practices have been recognized by the courts. In the case of *Schumacher v. Harriett*, (C. C. A. 4th, 1931), 52 Fed. (2nd) 817, it was stated:

“The duty of courts is to apply the principles of law and equity *to the conditions of our changing life*; and we have no doubt that in view of *modern banking practices*, the modern but well-settled doctrine of tracing trust funds is applicable to the situation here disclosed.” (Pages 820-21.)

That our statement that the minimum that the Special Master should have used was the lowest posted balances, and that the failure to use the lowest posted balances created a situation that was manifestly inequitable to Universal, we need but look at the computations shown on Schedule A. [Tr. p. 102.]

There, under date of November 19, 1929, the lowest posted balance and the lowest closing balance are each shown in excess of \$200,000.00, while the lowest balance adopted by the Special Master's theory approximates \$93,000.00. Had the Special Master used the lowest posted balances for that period, Universal would have been awarded liens practically *twice* the amount that was awarded by the Special Master, arising out of the first deposit of Universal funds on November 13, 1929. It is again interesting to note that under date of January 23, 1930, the lowest posted balance and the lowest daily closing balance are in the identical sum of \$466,764.36—both of which sums exceed by approximately \$130,000.00 the amount used by the Special Master at that date. Again on January 30, 1930, and on February 1, 1930, the lowest posted balances very closely approximate the lowest daily closing balances—both of which respective

amounts are far in excess of the amounts used by the Special Master under his computations.

While subsequent to February 1, 1930, there is a greater variance in the lowest posted balances, in that they are considerably less than the lowest daily closing balances, yet it is to be noted that the lowest posted balances almost invariably exceed the balances used by the Special Master.

The amount of the liens to which Universal is entitled by using the lowest posted balances is as follows:

Of the first \$750,000 taken from Universal a low balance of \$198,719.80 was reached on November 27th, 1929. Thus the liens of Universal resulting from the first taking are limited to this figure rather than the sum of \$272,704.61 which appears as the low closing balance.

Delaney Property	\$ 50,000.00
Storage Tanks, Rioco Refinery	44,540.00
Service Station, Franklin & Vermont, Los Angeles	500.00
S. S. Kekoskee	35,421.75
S. S. Larry Doheny)
S. S. Pat Doheny) 68,258.15
Terminal & Marine Facilities, Richmond Plant)	
	<hr/>
Total	\$198,719.90

No intermediate daily balance of less than \$200,000 appears for some time subsequent to the next taking so liens for the full \$200,000 may be established here in the same manner as under the theory previously discussed.

Land, Sacramento Distributing Plant	\$ 500.00
106,000 shares of Universal Stock) 199,500.00
Delaney Group)
	<hr/>
Total	\$200,000.00

It is again not quite as simple to explain the liens arising from the next group of takings under this theory, as was found in working out the liens under the daily closing balances, *supra*. We will concede, for the purpose of working out this theory, that the low balance of \$122,941.84 on February 25, 1930, occurred after the deposit of the Universal check of \$100,000 on the same day, as well as after the \$400,000 deposit on February 15th. Our recovery would then be limited to \$122,941.84 plus the \$100,000 deposited on February 27, 1930. After some expenditure on assets further limitations occurred as a result of low balances of \$113,324.49 on March 10, 1930, and of \$53,259.91 on March 18, 1930. Universal would then be entitled to trace its funds into the following assets and assert liens on the following property for the amounts listed:

Watson Refinery Vapor Recovery		
Plant	\$34,332.84	
Rioco Refinery, Storage Tanks....	48,000.00	
5100 shares of Universal Stock..	10,625.00	\$ 92,957.84
	<hr/>	
Delaney Property		50,000.00
Service Station, Franklin and Vermont, Los Angeles	7,500.00	
Watson Refinery Vapor Recovery		
Plant	34,332.43	
Rioco Refinery Storage Tanks....	11,427.48	53,259.91
	<hr/>	
	Total	<hr/> \$196,217.75

An intermediate daily low balance of \$69,303.89 on June 18, 1930, limits the recovery of the \$75,000.00 to that figure. The following liens result:

Watson Refinery Vapor Recovery Plant.....	\$34,332.43
Rioco Refinery Storage Tanks.....	34,971.46
	<hr/>
Total	\$69,303.89

Summarizing the total liens on each particular piece of property under the limitations of this theory we find Universal entitled to the following liens:

Delaney Property	\$100,000.00
Rioco Refinery Storage Tanks	138,938.94
Watson Refinery Vapor Recovery System.....	102,997.70
Tanker Kekoskee	35,421.75
106,000 shares of Universal Stock, Certifi- cates LX26, 27, 28, 32.....	199,500.00
5100 shares of Universal Stock, Certificate LX31	10,625.00
Service Station, Franklin and Vermont, Los Angeles	8,000.00
Land, Sacramento Distributing Plant.....	500.00
Tanker Larry Doheny)
Tanker Pat Doheny) 68,258.15
Richmond Marine Terminal)
	<hr/>
Total	\$664,241.54

with dates, likewise appears in Appendix A attached to
A full summary of all the data herein set out, together
this brief.

CONCLUSION.

It is respectfully submitted that in allocating to Universal liens upon the property purchased by Richfield, the Special Master erroneously used a method which did not do equity to Universal. The only true method of determining low balances was and is the daily closing balances, and this method should have been used, or at the very minimum, the lowest daily posted balances should have been used.

As was stated in the case of *Conqueror Trust Co. v. Fidelity & Deposit Co.* (C. C. A. 8th, 1933), 63 Fed. 2nd 833:

“This ‘minimum balance’ theory is of course merely a *mathematic means* of resolving a conflict of interest * * *.” (P. 840.)

There is nothing in the position taken by the Special Master that would commend itself to this court because the Special Master, disregarding the equitable rights of Universal, has adopted a minimum balance *below* which it is impossible to go. Such mathematical means so used by the Special Master penalizes an innocent party. It must not be overlooked that 52 per cent of any recovery in this action inures to the benefit of Richfield by virtue of its present ownership of 52 per cent of the outstanding stock of Universal.

Respectfully submitted,

A. L. WEIL,

LE ROY M. EDWARDS,

Attorneys for Appellant.

APPENDIX "A"

TABULATION SHOWING TAKINGS OF UNIVERSAL FUNDS BY RICHFIELD, ASSETS PURCHASED WITH COMMINGLED FUNDS, LOW BALANCES UNDER THREE THEORIES ADVANCED, AND AMOUNT TRACEABLE INTO EACH ASSET CLAIMED UNDER EACH THEORY

(1)	(2)	(3)	(4)	(5)	(6)	(7)	(8)	(9)
Date	Deposit of Universal Money in Richfield Account	Amount Paid on Property from Commingled Fund	Lowest Daily Closing Balances Between Takings of Universal Funds	Liens Claimed for the Following Sums by Reason of Column 4	Lowest Posted Balances Shown on Bank's Books During Any Day Between Takings of Universal Funds	Liens Claimed for the Following Sums by Reason of Column 6	Lowest Balance Ascertained by Deducting All Checks Cleared Each Day Without Crediting Deposits Made During the Same Day	Liens Claimed for the Following Sums by Reason of Column 8
1929								
Nov 13	\$ 750 000.00							
" 19			\$272 704.61		\$209 198.80		\$ 93 635.65	\$ 50 000.00
" 29		\$ 50 000.00		\$ 50 000.00		\$ 50 000.00		
" 30		44 540.00		44 540.00		44 540.00		
" 30		500.00		500.00		500.00		43 635.65
Dec 9		35 421.75		35 421.75		35 421.75		=====
" 23		164 746.20						
" 23		168 663.06		142 242.86		68 258.15		
" 23		190 914.94						
" 24				=====		=====	76 032.84 (red)	
" 31		49 385.00						
1930								
Jan 3		500.00						
" 3		50 000.00						
" 11		15 825.00						
" 20	200 000.00		466 764.36		466 764.36		336 646.20	
" 23							308 662.67	
" 24		500.00		500.00		500.00		500.00
" 27		221 202.08						
" 29				199 500.00		199 500.00		199 500.00
" 29		50 000.00		=====		=====	=====	=====
" 30		53 680.00						
" 30		500.00	464 148.47		462 088.47			
Feb 1	500 000.00	(red)	447 704.86		443 916.47	(red)	222 642.41 (red)	
" 15	100 000.00				172 136.10			
" 17							20 879.26	
" 24			296 779.62		20 925.52		128 412.10 (red)	
" 25	100 000.00		252 760.24		122 941.84		204 138.29	
" 26					204 342.03		272 948.76	
" 27	100 000.00							
Mar 1		34 332.84		34 332.84		34 332.84		34 332.84
" 1		48 000.00		48 000.00		48 000.00		48 000.00
" 4							239 919.57	
" 5		10 625.00		10 625.00		10 625.00	203 185.63	10 625.00
" 6				=====		=====	17 400.43	=====
" 8			209 201.80					
" 10					113 324.49			
" 12		50 000.00		50 000.00		50 000.00		17 400.43
" 18					53 259.91			=====
" 22		7 500.00		7 500.00		7 500.00		
" 25		34 332.43		34 332.43		34 332.43		
" 28		50 000.00		50 000.00		11 427.48		
Apr 2		50 000.00		50 000.00				
" 3		500.00		500.00				
" 7		4 500.00		4 500.00				
" 16							8 520.06	
" 21		34 332.43		12 369.37				
" 26		50 000.00		=====				
" 28		50 000.00						
May 1	\$	500.00						
" 1		825.00						
" 1		208.33						
" 2		208.33						
" 3		416.67						
" 3		156.25						
" 5		825.00	\$140 878.03					
" 6		41.67						
" 8		41.67						
" 9		104.17						
" 9		500.00						
" 12		104.17						
" 12		5 083.33						
" 15		3 125.00						
" 19		1 600.00						
" 19		4 375.00						
" 20		583.33						
" 20		3 541.67						
" 21		20 000.00						
" 23		34 332.43						
" 26							\$ 73 096.23 (red)	
" 27		2 083.33						
" 27		16 781.25						
" 28		7 172.92						
Jun 2		500.00						
" 4		50 000.00						
" 6	\$	75 000.00						
" 7			168 222.42		\$ 69 303.89			
" 18								
" 21								
" 25		34 332.43		\$ 34 332.43		\$ 34 332.43		122 078.81 (red)
" 27					45 336.49			
" 28		55 700.19		40 667.57		34 971.46		
" 28				=====		=====		
Jul 14							1 679 420.83 (red)	
" 15		34 332.43						
" 17		50 000.00						
" 31		500.00						
	\$ 1 625 000.00			\$849 864.25		\$664 241.54		\$403 993.92
				=====		=====		=====

Delaney group producing properties
 Rioco refinery storage tanks, Hynes, Calif.
 Service station at Franklin and Vermont, Los Angeles
 Steel tanker Kekoskee
 Steel tanker Larry Doheny
 Steel tanker Pat Doheny
 Richmond marine terminal, Contra Costa County, Calif.
 Rioco refinery storage tanks, Hynes, Calif.
 Service station at Franklin and Vermont, Los Angeles
 Delaney group producing properties
 Richville camp site, Backus property, Long Beach, Calif.
 Land, Sacramento distributing plant, Sacramento, Calif.
 106,000 shares capital stock Universal Consolidated Oil Company, certificates LX 26, 27, 28, 32
 Delaney group producing properties
 Rioco refinery storage tanks, Hynes, Calif.
 Service station at Franklin and Vermont, Los Angeles
 5,100 shares capital stock Universal Consolidated Oil Company, certificate #LX 31
 Watson refinery vapor recovery plant, Los Angeles County, Calif.
 Rioco refinery storage tanks, Hynes, Calif.
 Service station at Franklin and Vermont, Los Angeles
 Watson refinery vapor recovery plant, Los Angeles County, Calif.
 Rioco refinery storage tanks, Hynes, Calif.
 Delaney group producing properties
 Service station at Franklin and Vermont, Los Angeles
 Land, Sacramento distributing plant, Sacramento, Calif.
 Watson refinery vapor recovery plant, Los Angeles County, Calif.
 Delaney group producing properties
 Rioco refinery storage tanks, Hynes, Calif.
 Service station at Franklin and Vermont, Los Angeles
 400 Shares capital stock Univ. Cons. Oil Co., cert. #LX 34
 100 " do " LX 34
 100 " " LX 34
 200 " " LX 34
 75 " " LX 34
 400 " " LX 34
 20 " " LX 34
 20 " " LX 34
 50 " " LX 34
 Delaney group producing properties
 50 shares capital stock Univ. Cons. Oil Co., cert. #LX 34
 2,440 " do " LX 38
 1,500 " " LX 36
 Land, Sacramento distributing plant, Sacramento, Calif.
 2,100 shares capital stock Univ. Cons. Oil Co., cert. #LX 40
 280 " do " LX 38
 1,700 " " LX 39
 Land adjacent Rioco refinery, Hynes, Calif.
 Watson refinery vapor recovery plant, Los Angeles County, Calif.
 1,000 shares capital stock Univ. Cons. Oil Co., cert. #L3020
 8,055 " do " LX 42
 3,443 " " LX 43
 Service station at Franklin and Vermont, Los Angeles
 Delaney group producing properties

1. The first part of the document
describes the general principles
of the proposed system.

2. The second part of the document
describes the detailed design
of the proposed system.

3. The third part of the document
describes the implementation
of the proposed system.

4. The fourth part of the document
describes the results of the
implementation of the proposed system.

5. The fifth part of the document
describes the conclusions of the
implementation of the proposed system.

6. The sixth part of the document
describes the future work
of the implementation of the proposed system.

7. The seventh part of the document
describes the references of the
implementation of the proposed system.

8. The eighth part of the document
describes the appendix of the
implementation of the proposed system.

9. The ninth part of the document
describes the index of the
implementation of the proposed system.

10. The tenth part of the document
describes the bibliography of the
implementation of the proposed system.

1
2
3
4
5
6
7
8
9
10
11
12
13
14
15
16
17
18
19
20
21
22
23
24
25
26
27
28
29
30
31
32
33
34
35
36
37
38
39
40
41
42
43
44
45
46
47
48
49
50
51
52
53
54
55
56
57
58
59
60
61
62
63
64
65
66
67
68
69
70
71
72
73
74
75
76
77
78
79
80
81
82
83
84
85
86
87
88
89
90
91
92
93
94
95
96
97
98
99
100

8

In the United States
Circuit Court of Appeals
For the Ninth Circuit.

THE REPUBLIC SUPPLY COMPANY OF CALIFORNIA, a corporation,
Complainant,
vs.
RICHFIELD OIL COMPANY OF CALIFORNIA, a corporation,
Defendant.

SECURITY-FIRST NATIONAL BANK OF LOS ANGELES, as Trustee, GEORGE ARMSBY, F. S. BAER, HARRY J. BAUER, STANTON GRIFFIS, ROBERT E. HUNTER and ALBERT E. VAN COURT, known and designated as Richfield Bondholders' Committee,
Appellants and Cross-Appellants,

vs.
UNIVERSAL CONSOLIDATED OIL COMPANY, a California corporation,
Intervenor, Appellee and Cross-Appellant.

THE CHASE NATIONAL BANK OF THE CITY OF NEW YORK, BANK OF AMERICA, a corporation, PAN AMERICAN PETROLEUM COMPANY, a corporation, WILLIAM C. McDUFFIE, as Receiver for Pan American Petroleum Company, a corporation, RICHFIELD OIL COMPANY OF CALIFORNIA, a corporation, UNITED STATES OF AMERICA, THE REPUBLIC SUPPLY COMPANY OF CALIFORNIA, a corporation, CITIES SERVICE COMPANY, a corporation, ROBERT C. ADAMS, THOMAS B. EASTLAND, EDWARD F. HAYES and RICHARD W. MILLAR, known and designated as Pan American Bondholders' Committee, G. PARKER TOMS, ROBERT C. ADAMS, F. S. BAER, ROBERT E. HUNTER, HENRY S. McKEE and RICHARD W. MILLAR, known and designated as Richfield Pan

(Continued on Inside Cover.)

BRIEF OF APPELLANTS AND CROSS-APPELLEES SECURITY-FIRST NATIONAL BANK OF LOS ANGELES, AS TRUSTEE, GEORGE ARMSBY, F. S. BAER, HARRY J. BAUER, STANTON GRIFFIS, ROBERT E. HUNTER AND ALBERT E. VAN COURT, KNOWN AND DESIGNATED AS RICHFIELD BONDHOLDERS' COMMITTEE.



TOPICAL INDEX.

	PAGE
Statement of the case.....	4
Specification of the errors relied upon.....	13
Argument	18
1. The federal equity doctrine as to the tracing of trust funds is controlling in this case. That doctrine requires a strict tracing of actual trust funds into a specific fund or into specific property	25
2. Under the federal decisions mere proof of the purchase of properties out of a fund in which trust and private funds have been commingled is insufficient to show a tracing of the trust funds into such properties.....	26
3. A mere showing that trust funds have gone to swell the assets of an insolvent is insufficient to impress a trust upon properties acquired through the use of the general funds of the insolvent with which the trust funds have been blended	42
4. Purchases made out of a commingled fund are not ipso facto chargeable with a trust.....	48
5. The principle of in re Oatway has never been followed in the federal courts to the extent of doing away with the strict tracing principle in cases dealing with the acquisition of real or personal property out of a commingled fund	57
6. If it be assumed that the impressment of a trust upon the properties involved was proper, the amount thereof could not exceed the amount of the lowest balance in the account prior to a given purchase and subsequent to the last deposit of trust moneys therein, such low balance to be computed by deducting all withdrawals from the account during each day from the opening balance of such day, as held by the master and the court.....	65
Conclusion	75

TABLE OF AUTHORITIES CITED.

	PAGE
American Surety Co. v. Jackson, 24 Fed. (2d) 768.....	50, 54
A. O. Brown & Co., In re, 193 Fed. 24.....	40, 44, 67, 73
Beard v. Independent District, 88 Fed. 375.....	25
Board of Commissioners v. Strawn, 157 Fed. 49.....	42, 53, 54
Brennan v. Tillinghast, 201 Fed. 609.....	22, 59, 60, 63
City of Spokane v. First National Bank of Spokane, 68 Fed. 982	50
Ellerbe v. Studebaker Corp., 21 Fed. (2d) 993.....	46
Empire State Surety Co. v. Carroll County, 194 Fed. 593.....	42, 58
Equitable Trust Co. v. Conn. Brass & Manuf. Co., 10 Fed. (2d) 1913.....	51
Frelinghuysen v. Nugent, 36 Fed. 229.....	23, 34, 36
J. M. Acheson Co., In re, 170 Fed. 427.....	48, 55
John Deere Plow Co. v. McDavid, 137 Fed. 802.....	25
Kemp v. Elmer Co., 56 Fed. (2d) 657.....	51
Knatchbull v. Hallett, 13 Ch. D. 696.....	21, 23
McIntyre, In re, 185 Fed. 96, 108.....	25
Mitchell v. Dunn, 211 Cal. 129.....	64
Oatway, In re, 2 Ch. D. 356.....	57
Pacat Finance Corporation, In re, 27 Fed. (2d) 810.....	22, 59, 60, 61, 67
People v. California Safe Deposit Company, 175 Cal. 756.....	65
Peters v. Bain, 133 U. S. 670.....	23, 24, 26, 33, 36, 41, 46, 56, 57, 60
Schumacher v. Harriett, 52 Fed. (2d) 817.....	46
Schuyler v. Littlefield, 232 U. S. 707.....	37, 39, 40, 57, 58, 60, 66
Smith v. Town of Au Gres, 150 Fed. 258.....	53
Southern Cotton Oil Co. v. Elliotte, 218 Fed. 567.....	52
Spokane County v. First National Bank, 68 Fed. 979.....	51

In the United States
Circuit Court of Appeals
For the Ninth Circuit.

THE REPUBLIC SUPPLY COMPANY OF CALIFORNIA, a corporation,

Complainant,

vs.

RICHFIELD OIL COMPANY OF CALIFORNIA, a corporation,
Defendant.

SECURITY-FIRST NATIONAL BANK OF LOS ANGELES, as Trustee, GEORGE ARMSBY, F. S. BAER, HARRY J. BAUER, STANTON GRIFFIS, ROBERT E. HUNTER and ALBERT E. VAN COURT, known and designated as Richfield Bondholders' Committee,

Appellants and Cross-Appellants,

vs.

UNIVERSAL CONSOLIDATED OIL COMPANY, a California corporation,

Intervenor, Appellee and Cross-Appellant.

THE CHASE NATIONAL BANK OF THE CITY OF NEW YORK, BANK OF AMERICA, a corporation, PAN AMERICAN PETROLEUM COMPANY, a corporation, WILLIAM C. McDUFFIE, as Receiver for Pan American Petroleum Company, a corporation, RICHFIELD OIL COMPANY OF CALIFORNIA, a corporation, UNITED STATES OF AMERICA, THE REPUBLIC SUPPLY COMPANY OF CALIFORNIA, a corporation, CITIES SERVICE COMPANY, a corporation, ROBERT C. ADAMS, THOMAS B. EASTLAND, EDWARD F. HAYES and RICHARD W. MILLAR, known and designated as Pan American Bondholders' Committee, G. PARKER TOMS, ROBERT C. ADAMS, F. S. BAER, ROBERT E. HUNTER, HENRY S. McKEE and RICHARD W. MILLAR, known and designated as Richfield Pan American Reorganization Committee, WILLIAM C. McDUFFIE, as Receiver of Richfield Oil Company of California, SECURITY-FIRST NATIONAL BANK OF LOS ANGELES, a national banking association, PACIFIC AMERICAN COMPANY, a corporation, AMERICAN COMPANY, a corporation, MANUFACTURERS TRUST COMPANY OF NEW YORK, a corporation, CITIZENS NATIONAL TRUST & SAVINGS BANK OF LOS ANGELES, a national banking association, FIRST NATIONAL BANK AND TRUST COMPANY OF SEATTLE, a national banking association, CONTINENTAL ILLINOIS BANK AND TRUST COMPANY, a corporation, THE FIRST NATIONAL BANK OF CHICAGO, a national banking association, CHEMICAL NATIONAL BANK AND TRUST COMPANY, a national banking association, and CALIFORNIA BANK, a corporation, M. W. LOWERY, HENRY S. McKEE, O. C. FIELD, R. R. TEMPLETON, known and designated as Richfield Unsecured Creditors' Committee,

Appellees.

**BRIEF OF APPELLANTS AND CROSS-APPEL-
LEES SECURITY-FIRST NATIONAL BANK
OF LOS ANGELES, AS TRUSTEE, GEORGE
ARMSBY, F. S. BAER, HARRY J. BAUER,
STANTON GRIFFIS, ROBERT E. HUNTER
AND ALBERT E. VAN COURT, KNOWN
AND DESIGNATED AS RICHFIELD BOND-
HOLDERS' COMMITTEE.**

Statement of the Case.

Prior to November 13, 1929, Richfield Oil Company of California (hereinafter referred to as Richfield) obtained control of the Board of Directors of Universal Consolidated Oil Company (hereinafter referred to as Universal) and thereafter and prior to January 15, 1931, effected the transfer of Universal funds to the Richfield general banking account in the Security-First National Bank of Los Angeles in a net sum of \$1,625,000.00. [Tr. p. 97.] The Richfield account in question was an ordinary checking account and the Universal funds, when deposited therein, were commingled with Richfield moneys concurrently on deposit. [Tr. p. 97.] At the time of the first deposit of Universal moneys on November 13, 1929, Richfield had a large balance in the account. [Tr. pp. 97, 98.] That balance fluctuated from day to day in accordance with the deposits and withdrawals constantly being made by Richfield. [Tr. p. 98.] The deposits from sources other than Universal amounted to \$81,903,908.39 from November 13, 1929, to January 14, 1931. [Tr. p. 98.] By January 8, 1931, one week before the appointment of the Richfield receiver, the account had been wholly depleted and there existed an overdraft of some \$18,000.00 at the close of business on that day. [Tr. p. 98.]

Upon these facts Universal intervened in the consolidated foreclosure proceeding then pending against the properties subject to the Richfield bond indenture in order to obtain an adjudication of priority in its favor over the bond issue as to certain parcels of property which it claimed had been purchased by Richfield through the use of Universal funds assertedly in the commingled account. [Tr. p. 67.] The issues joined as to the allegations of Universal's bill in intervention were duly referred to the Honorable William A. Bowen, as Special Master, for hearing, which hearing was consolidated with that based upon the general claim which Universal had also filed against Richfield in the receivership proceeding and which general claim was later allowed. The Special Master found that the transactions between Universal and Richfield were not in the nature of loans or advances from the former to the latter, as was contended, but actually consisted of misappropriations which rendered Richfield a constructive trustee for the benefit of Universal as to all moneys obtained from the latter. The propriety of this finding is not questioned here.

Secondly, the Special Master found that Universal had succeeded in tracing an aggregate sum of \$403,993.92 into certain properties described in his report [Tr. pp. 205-206] and accordingly recommended that a trust superior to any right, title, interest or lien of appellant Bank as Trustee under the bond issue be impressed upon such properties. The properties in question, together with the amounts as to which they were declared subject to the trust in favor of Universal, are set forth *infra* in the exceptions to the report of the Special Master contained in the specification of errors relied upon herein.

Timely exceptions were filed to the Master's Report both by appellants [Tr. p. 208] and by Universal [Tr. p. 214], which exceptions were duly overruled by the court and the report approved. [Tr. pp. 32, 36.] It may be stated, more or less parenthetically, that appellant's exceptions were filed on the theory that the evidence did not show any actual tracing of the commingled funds into the properties involved, such as is required by the legal and equitable principles applicable to such a situation. On the other hand, Universal's exceptions were filed upon the theory that it had succeeded in tracing an even larger amount (\$849,864.25) and hence, that the Master should have declared a trust in that sum. These conflicting contentions reflect the questions which are presented for determination respectively in this appeal and in the cross-appeal of Universal.

The manner in which these questions are raised is perhaps best illustrated by setting forth the formula employed by the Master in applying his theory as to the tracing of Universal funds from the commingled account into the properties as to which he recommended the impressment of a trust. We quote from his report [Tr. p. 173]:

“A trustee deposits trust money in an account containing his own funds, pays for an identified piece of property out of the mixed fund, and afterwards dissipates the remainder. Between the deposit and the payment he has daily deposited his own funds and daily withdrawn from the mixed fund, but the account has never been exhausted. The question is,

whether a trust is to be declared in the identified piece of property for the payment thereon, limited by the amount of the trust money deposited or by the intervening low balance in the account, whichever is less.”

The Master recommended that under such circumstances a trust should be declared and the court approved this recommendation.

The question as to whether any trust may be declared under this “low balance” theory constitutes the main question involved in this appeal. As to the cross-appeal of Universal, however, the question involved is whether or not the Master applied the proper “low balance” test in impressing the trust which he did declare.

Three theories as to the proper low balance were advanced by the parties, assuming, of course, the propriety of declaring a trust based upon any low balance theory. These were, first, the lowest daily closing balance in the Richfield banking account; second, the lowest intermediate posted balance shown on the Bank’s books during the course of business on a given day; and, third, the low balance ascertained by deducting from the opening balance of any given day all checks cleared each day by crediting deposits made during that day. [Tr. pp. 147-148.]

The Master chose the third method. [Tr. p. 150.] Briefly, it was his view that the first method did not apply “for the reason that by its nature it necessarily disregards the actual order of deposits and withdrawals in point of time, and consequently does not reflect the true state of the account at any time since the previous

closing balance.” [Tr. p. 151.] He disregarded the second method because the intermediate daily balance theory disregarded the actual order of deposits and withdrawals in point of time due to the fact that under the practice of the Bank such posting ignores both deposits and withdrawals which might have been made prior to the actual posting without the records of such deposits or withdrawals being before the posting bookkeeper at the time he cast his balance. [Tr. pp. 148-150.] In view of these facts it became obvious that the third method, that of deducting all outgoing checks from the opening daily balance, was the only way in which Universal could sustain its burden of showing with the requisite certainty what the low balance on any given day actually was, upon an “irreducible minimum” theory. Appellants agree with the conclusion of the Master as to the propriety of applying the method in question if, and only if, it be held that any low balance method is proper in effecting a tracing of trust funds into specific properties. The following schedule which is reproduced from the statement of evidence set forth in the agreed statement of the case [Tr. pp. 102-105] sufficiently sets forth not only the results of the three alternative methods of ascertaining the low balance above referred to, but also all of the evidence necessary in the determination of both the appeal of these appellants and the cross-appeal of cross-appellant Universal. The “Universal deposits” referred to in the schedule, of course, are deposits of the misappropriated Universal moneys in the general checking account of Richfield.

(1)	(2)	(3)	(4)	(5)	(6)
Date	Universal Deposits	Lowest Daily Closing Balances Between Takings of Universal Funds	Lowest Posted Balances Shown on Bank's Books During any Day Between Takings of Universal Funds	Lowest Balance Ascertained by Subtracting From Opening Balance All Checks Cleared Each Day Before Crediting Deposits Made During the Same Day	Property on Which Payments Were Made and Amount Paid on Such Property from Said Bank Account
1929					
Nov 13	\$750,000.00				
" 19		\$272,704.61	\$209,198.80	\$ 93,635.65	\$ 50,000.00 Parcel 5
" 27			198,719.90		44,540.00 Parcel 2
" 29					500.00 Parcel 1
" 30					35,421.75 Parcel 9
" 30					164,746.20 Parcel 8
Dec 9					168,663.06 Parcel 7
" 23					190,914.94 Parcel 6
" 23					
" 24				76,032.84 (red)	
" 31					49,385.00 Parcel 2

1930

Jan 3				500.00	Parcel 1
" 3				50,000.00	Parcel 5
" 20	200,000.00				
" 23		466,764.36	466,764.36	336,646.20	
" 24				308,662.67	
" 27					
" 29				500.00	Parcel 4
" 29				221,202.08	Parcel 10
" 29				50,000.00	Parcel 5
" 30				53,680.00	Parcel 2
" 30		464,148.47	462,088.47	500.00	Parcel 1

Feb 1		447,704.86	443,916.47		
" 15	500,000.00	(red)	172,136.10	222,642.41 (red)	
" 24		296,779.62	20,925.52	20,879.26	
" 25	100,000.00	252,760.24	122,941.84	128,412.10 (red)	
" 26			204,342.03	204,138.29	
" 27	100,000.00			272,948.76	

Mar 1				
" 1			34,332.84	Parcel 3
" 4			48,000.00	Parcel 2
" 5		239,919.57		
" 6		203,185.63		
" 8		17,400.43		
" 10	209,201.80			
" 12		113,324.49		
" 18		53,259.91		
" 22			50,000.00	Parcel 5
" 25			7,500.00	Parcel 1
" 28			34,332.43	Parcel 3
Apr 2			50,000.00	Parcel 2
" 3			50,000.00	Parcel 5
" 7			500.00	Parcel 1
" 16			4,500.00	Parcel 4
" 21		8,520.06		
			34,332.43	Parcel 3

SCHEDULE A (Continued)

(1)	(2)	(3)	(4)	(5)	(6)
1930					
Apr 26					\$ 50,000.00 Parcel 5
“ 28					50,000.00 Parcel 2
May 5		\$140,878.03			825.00
Jun 6	\$75,000.00			\$ 114,164.03 (red)	
“ 7		168,222.42			
“ 18			\$69,303.89		
“ 21				122,078.81 (red)	
“ 25					34,332.43 Parcel 3
“ 27			45,336.49		
“ 28					55,700.19 Parcel 2
Jul 14				1,679,420.83 (red)	
“ 15					34,332.43 Parcel 3
“ 17					50,000.00 Parcel 5
“ 31					500.00 Parcel 1

Specification of the Errors Relied Upon.

Inasmuch as the error alleged concerns a ruling of the court upon the report of a Master and consisted in the approval of such report and the overruling of all exceptions thereto, we here set forth the exceptions [Tr. p. 208] filed by appellants to such report:

“Now comes Security-First National Bank of Los Angeles, a national banking association, plaintiff in the above entitled cause, and excepts to the report of the Honorable William A. Bowen, Special Master herein, filed in the office of the clerk of this court on the 26th day of May, 1933, in the following particulars, to-wit:

1. To the finding of fact and/or conclusion of law (Report p. 82, line 26) that the lien of the bond or trust indenture sought to be foreclosed herein is subject to the trust interest of intervenor, Universal Consolidated Oil Company, a corporation, as found and declared by said Special Master as to the parcels of property specified in said report.

2. To the finding of fact and/or conclusion of law (Report p. 76, line 24) that said intervenor has sufficiently identified and traced its funds into the various parcels specified in the report of said Special Master and hereinafter specified, either in the amounts set forth or otherwise.

3. To the finding of fact and/or conclusion of law (Report p. 57, line 13) that the various parcels specified in said report and hereinafter specified either in toto or to the respective amounts or to the extent of the trust imposed upon them in favor of said intervenor constitute the property of intervenor in a substituted form.

4. To the conclusion of law (Report p. 83, line 4) that said intervenor is entitled to have a trust imposed upon the various parcels specified in said report and hereinafter specified either in the amounts specified therein or in any amounts whatever.

5. To the conclusion of law (Report p. 76, line 24) that the evidence herein constitutes a sufficient tracing and identification of the funds of said intervenor to warrant the imposition of a trust in favor of said intervenor upon the various parcels specified in said report and hereinafter specified either in the amounts set forth therein, or in any amounts whatever.

6. To the conclusion of law (Report p. 67-a, line 6) that the investments revealed by the evidence (to-wit, the purchases by defendant Richfield Oil Company of California, a corporation, of the parcels specified in said report and hereinafter specified) should be attributed either in whole or in part to the trust funds of intervenor then and there in the possession of said defendant and commingled with private funds belonging to said defendant.

7. To the conclusion of law (Report p. 67-a, line 6) that in the case of purchases of real or personal property made by a trustee out of a fund in which trust and private funds had theretofore been commingled, the trust moneys may be traced into such properties wholly through the application of presumptions and wholly without evidence of any actual devotion of such trust funds or any part thereof as distinguished from the commingled funds to the respective purchases in question.

8. To the failure of said Special Master to conclude that the evidence was insufficient to support a finding that intervenor had actually traced into the

parcels specified in said report and hereinafter specified any of the trust funds of intervenor formerly in the possession of defendant Richfield Oil Company of California, a corporation, as distinguished from the commingled fund in which said trust funds and the private funds of said defendant were blended.

9. To the failure of said Special Master to conclude and to declare that mere proof of purchases out of a fund in which trust and private moneys have been commingled is wholly insufficient to warrant the imposition of a trust upon the property so purchased.

10. To the recommendations, and each of them, of said Special Master as embodied in his said report (p. 83, line 4), to-wit:

(a) That a trust be declared and enforced in favor of Universal Consolidated Oil Company, a corporation, in the amounts specified below and upon such right, title and interest as may appear to be vested in Richfield Oil Company of California, a corporation, and its receiver, and superior to any right, title, interest or lien of this plaintiff under the bond or trust indenture sought to be foreclosed herein in and to the following properties and parcels described in said report, to-wit:

Parcel 1.	“Franklin & Vermont Service Station”, real property.	\$ 492.60
Parcel 2:	“Delaney Producing Property”, leaseholds.	103,442.33
Parcels 3 and 4:	Ten storage tanks, personal property.	91,881.85
Parcel 5:	“Mull Property” real property.	500.00

Parcel 6: "Vapor Recovery Plant", personal property.	34,332.84
Parcel 7: 106,000 shares of Universal Stock, Certs. LX:26, 27, 28 and 32	162,719.30
Parcel 8: 5,100 shares of Universal Stock, cert. LX 31	10,625.00
	<hr/>
	\$403,993.92

(b) That upon any sale to be had in this action the aforesaid parcels be offered for sale and sold separately from each other and from all other property, and that Universal Consolidated Oil Company be allowed a first charge upon the gross proceeds of the sale of each of said parcels in the amount above specified in respect thereof, the amount of each sale to be a charge upon any surplus realized from such sale over the amount receivable as aforesaid by said Universal Consolidated Oil Company, a corporation; and

(c) That jurisdiction be retained for the purpose of awarding such other relief as may appear to be equitable for the enforcement of said trust in the event there shall be a failure to effect a sale in the case of any parcel or parcels.

Dated this 15th day of June, 1933.

O'MELVENY, TULLER & MYERS
and Pierce Works
and Clinton La Tourette

Solicitors for Plaintiff, Security-First National Bank
of Los Angeles, a national banking association."

The foregoing exceptions were overruled and the report of the Master approved by order of the District Judge duly made and entered [Tr. pp. 36, 42], exceptions being allowed to appellant. [Tr. pp. 39, 44.]

Appellant specifies as error relied upon by it upon this appeal, and states that the order appealed from is erroneous by reason of, the action of the court in overruling the foregoing exceptions and each of them and in approving the aforesaid report of the Special Master without correcting it or taking other action relative thereto in the particulars as to which appellant's exceptions were specified as above set forth.

It is the contention of appellants that the evidence was wholly insufficient to support any finding of fact to the effect that Universal funds had been traced into any properties whatever, and hence that the impressment of a trust upon the above properties was wholly erroneous.

Argument.

Since the effect of the order appealed from was merely to approve the findings, conclusions and recommendations of the Special Master, in presenting our argument we shall proceed as if we were directly attacking the Master's report. It will, of course, be understood, however, that we are at all times referring to the report and to the holdings of the Master from the standpoint of their having been adopted and approved by the court.

In the presentation of its argument in support of their own appeal appellants will rely upon the following points:

1. THE FEDERAL EQUITY DOCTRINE AS TO THE TRACING OF TRUST FUNDS IS CONTROLLING IN THIS CASE. THAT DOCTRINE REQUIRES A STRICT TRACING OF ACTUAL TRUST FUNDS INTO A SPECIFIC FUND OR INTO SPECIFIC PROPERTY.
2. UNDER THE FEDERAL DECISIONS MERE PROOF OF THE PURCHASE OF PROPERTIES OUT OF A FUND IN WHICH TRUST AND PRIVATE FUNDS HAVE BEEN COMMINGLED IS INSUFFICIENT TO SHOW A TRACING OF THE TRUST FUNDS INTO SUCH PROPERTIES.
3. A MERE SHOWING THAT TRUST FUNDS HAVE GONE TO SWELL THE ASSETS OF AN INSOLVENT IS INSUFFICIENT TO IMPRESS A TRUST UPON PROPERTIES ACQUIRED THROUGH THE USE OF THE GENERAL FUNDS OF THE INSOLVENT WITH WHICH THE TRUST FUNDS HAVE BEEN BLENDED.
4. PURCHASES MADE OUT OF A COMMINGLED FUND ARE NOT IPSO FACTO CHARGEABLE WITH A TRUST.

5. THE PRINCIPLE OF IN RE OATWAY HAS NEVER BEEN FOLLOWED IN THE FEDERAL COURTS TO THE EXTENT OF DOING AWAY WITH THE STRICT TRACING PRINCIPLE IN CASES DEALING WITH THE ACQUISITION OF REAL OR PERSONAL PROPERTY OUT OF A COMMINGLED FUND.

In our capacity as cross-appellees in the Universal cross-appeal we will rely upon the following point:

6. IF IT BE ASSUMED THAT THE IMPRESSMENT OF A TRUST UPON THE PROPERTIES INVOLVED WAS PROPER, THE AMOUNT THEREOF COULD NOT EXCEED THE AMOUNT OF THE LOWEST BALANCE IN THE ACCOUNT PRIOR TO A GIVEN PURCHASE AND SUBSEQUENT TO THE LAST DEPOSIT OF TRUST MONEYS THEREIN, SUCH LOW BALANCE TO BE COMPUTED BY DEDUCTING ALL WITHDRAWALS FROM THE ACCOUNT DURING EACH DAY FROM THE OPENING BALANCE OF SUCH DAY, AS HELD BY THE MASTER AND THE COURT.

Gist of the Controversy.

Two main questions were presented to the Special Master for decision. These were, first, whether the transfer of funds from Universal to Richfield was a conversion or misappropriation as distinguished from a series of loans or advances made upon open account; and *second*, if so, whether appellee had succeeded in tracing the misappropriated (and hence trust) funds into specific properties.

Each of the above questions was decided by the Master in the affirmative. Inasmuch as the decision as to the first point may properly be said to have been supported

by the evidence, despite a conflict, appellant does not question it here. As to the decision on the second point, however, plaintiff is unable to agree in principle with the Master's, and hence the court's, views on the subject of tracing trust funds.

We respectfully submit that the holding in this latter respect is contrary to the well-settled rule in the Federal jurisdiction, which requires one who would trace trust moneys into other forms of property to show that such trust moneys actually were employed in the acquisition of the property in question.

In lieu of requiring such an actual tracing the Master first applied to the Richfield bank account what has been variously referred to as the fiction, presumption or rule of estoppel to the effect that funds dissipated by a faithless trustee are his own, while those retained by him include the funds of the *cestui*. The Master then limited such funds of the *cestui* to the amount of the lowest balance shown in the account subsequent to the last deposit of trust moneys in order to ascertain the *cestui's* presumed balance as of the date of a particular purchase. The purchase then being made it was presumed that the moneys of the *cestui* then presumptively in the account went into the purchase and a trust was accordingly impressed upon the property acquired to the extent of such presumed balance. In no case was there any evidence that trust moneys or any part of them actually went into the purchase of the properties in question.

In view of this fact we respectfully submit that the method of tracing applied in this case is directly contrary to the requirements of actual tracing which have

been repeatedly laid down in cases of this nature. Furthermore, the history of the development of the principles applicable to the tracing of trust funds fully supports our views. It will not be disputed that it was originally the law that trust property could only be followed through a specific identification thereof and that nothing else would suffice. Thus, where specific trust moneys were commingled in a fund with private funds of the trustee the right to recover the specific moneys was lost and the *cestui* immediately became relegated to the position of a general creditor. This situation brought about the first exception to the general rule. Thereafter the *cestui* was allowed to reclaim as his own money in an amount equivalent to that theretofore delivered to him by the trustee without the necessity of a specific identification of the precise coins delivered by him. Otherwise the rules remained the same.

The next exception again related to the right to reclaim from commingled funds. In cases where the faithless trustee had dissipated part of the commingled moneys, the balance remaining in his hands, it was held proper to "presume" that the trustee had expended his own moneys first, thus permitting the *cestui* to reclaim from the balance. This was the rule of *Knatchbull v. Hallett* (1878), 13 Ch. D. 696; a rule which the Federal courts have consistently followed and applied in cases where reclamation from a fund is sought.

The next step consisted of an extension of the first exception with regard to commingled funds whereby it

was declared that a transfer of commingled trust and personal moneys from one fund of the trustee to another would warrant a tracing into the second fund.

Brennan v. Tillinghast, 201 Fed. 609 (C. C. A. 6th, 1913);

In re Pacat Finance Corporation, 27 Fed. (2d) 810 (C. C. A. 2d, 1928).

Thus, as far as the Federal courts have gone, it will have been noted that each of the foregoing exceptions relate to the matter of tracing into a commingled fund or funds of *money*. None of them relate to a tracing out of a commingled fund into parcels of real or personal property acquired therefrom, which is our case. In other words, it is our position that it always has been, and it now is the law that in order to trace trust funds into other forms of property acquired by the use of such funds, there must be proof that *actual trust moneys as distinguished from a mere hypothetical or presumptive substitute therefor were employed in the purchase or other acquisition*. We have only found one case indicating in anywise to the contrary and that is the case of *In re Oatway* (1903), 2 Ch. D. 356, which has never been followed in the United States as to this proposition and which is, as a matter of fact, contrary to the principles laid down by the Supreme Court of the United States in *Peters v. Bain*, a case which will hereinafter be discussed in detail.

At the outset it may be said that there is no great divergence of opinion in the present matter as to the general principles applicable to the tracing of trust funds. All recognize the right to trace such moneys into a specifically identified fund or into specifically identified property. All recognize the existence of a "vanishing point" beyond which such tracing may not proceed and by reason of which the asserted *cestui* must be relegated to the position of a general creditor. Recognition is also mutually given to the modern doctrine that money need not be earmarked and that a mere commingling of money in a fund will not of itself defeat the *cestui's* right to reclaim from such fund. Necessarily, there is no dispute whatever as regards the right of intervener to trace or the fact that it has traced its trust funds into the Richfield bank account in the present case. Provided the doctrine of *Knatchbull v. Hallett* (*supra*), may properly be extended to the case of a trustee *ex maleficio*, it would also be conceded that had the Richfield bank account, when taken over by the receiver, contained assets sufficient to satisfy the claim of Universal, the latter could have reclaimed its presumed moneys from the fund, subject only to the limitations of the intermediate low balance principle as declared by the Master herein in his report. This, however, is as far as the *Hallett* exception has been carried.

Frelinghuysen v. Nugent (1888), 36 Fed. 229;

Peters v. Bain (1889), 133 U. S. 670, *infra*.

Inasmuch as the account had been wiped out, however, prior to that time, it then became necessary that the intervener go a step farther and attempt to trace the trust funds into specific properties which had been purchased by Richfield. This, of course, necessitated a showing that there were actually trust funds *in* Richfield's possession at the time of each purchase and that they were actually used in connection therewith. No such showing was made. This being so, we find that the Master has actually held that mere proof of purchases of property out of a fund in which trust and private moneys have previously been commingled is sufficient to warrant the court in impressing a trust upon such properties to the extent of a "presumed" *cestui's* balance and without the necessity of further tracing (and this means of actually tracing), the trust moneys into such properties.

Such a contention does violence to a requirement which the Federal courts of the United States have always held paramount in such cases. This requirement is that where it is sought to follow trust moneys into a specific piece of property it must be shown that actual trust moneys (and not a mere synthetic or "presumptive" substitute therefor) went into the purchase thereof. Otherwise, the tracing is insufficient or, in other words, the "vanishing point" above referred to has been reached, for the Hallett presumption clearly has no application where a tracing from a commingled fund of *money* into acquired *property* is concerned.

Peters v. Bain, infra.

1. **The Federal Equity Doctrine as to the Tracing of Trust Funds Is Controlling in This Case. That Doctrine Requires a Strict Tracing of Actual Trust Funds Into a Specific Fund or Into Specific Property.**

It is settled law that the Federal courts will not follow state decisions with regard to the tracing of trust funds. Thus in *John Deere Plow Co. v. McDavid*, 137 Fed. 802 (C. C. A. 8th, 1905), arising in Missouri, it was held that a matter of tracing funds concerned "a rule of preference in equity and upon that question the Federal decisions must control in this court." Likewise, in *Beard v. Independent District*, 88 Fed. 375 (C. C. A. 8th, 1898), the Circuit Court of Appeals refused to follow the Supreme Court of Iowa, stating:

"If such right (to follow trust funds) exists, it is not created by the statute but is based upon the general principles of law and equity applicable to the circumstances; and the rulings of the Supreme Court are not conclusive upon the latter question, nor can it be rightfully said that they constitute a rule of property which other courts are bound to follow and . . . we cannot agree with the learned judge below in holding that this consideration requires a decision of the question involved in this case in accordance with the rulings of the Supreme Court of Iowa, if the same are not in accord with the rules laid down by the Supreme Court of the United States or established by the decided weight of authority in the cases by the courts in other states."

Again we find in *In re McIntyre*, 185 Fed. 96, 108 (C. C. A. 2d, 1911), the following:

"While the doctrine of following trust funds has been much extended in the modern decisions there has

never been a departure in the Federal courts from the principle that there must be some identification of the property sought to be charged with the trust funds.”

With this thought in mind it will be instructive at this time to refer to the leading cases under the Federal rule and to apply the principles of strict tracing laid down by them to the facts of the instant case.

2. Under the Federal Decisions Mere Proof of the Purchase of Properties Out of a Fund in Which Trust and Private Funds Have Been Commingled Is Insufficient to Show a Tracing of the Trust Funds Into Such Properties.

The above was squarely held in the case of *Peters v. Bain* (1889), 133 U. S. 670, 678, 693. In that case the partners of Bain & Bro., private bankers, became officers and directors of the Exchange National Bank of Norfolk. Shortly thereafter the firm began to absorb and to use the funds of the bank in their business until at one time their indebtedness to the bank exceeded one million dollars. By reason of this situation the bank was forced to close its doors. At the same time the Bains made an assignment for the benefit of their creditors. The resulting litigation was instituted by the receiver of the bank for the purpose of, first, setting aside the assignment, and, second, charging the property in the hands of the assignees with a trust in favor of the bank upon the theory that it had been bought with the moneys of the bank. The similarity of the facts in the case with those revealed by the evidence in the instant proceeding is manifest. Upon the trial it developed that in certain cases properties had been

bought by the Bains with moneys taken directly from the bank and immediately applied for that purpose. As to this class the trust was declared subject to the rights of *bona fide* purchasers, no commingling of funds having taken place. In other cases properties were bought by the Bains with commingled funds which had been augmented by moneys received from the bank as well as from other sources and as to this class the trust was disallowed because of the inability of the receiver to establish that these purchases had actually been made with trust funds. It will immediately be perceived that this last situation was identical with that presented by the evidence in the instant case.

The opinion in the Circuit Court in the *Bain* case was written by Chief Justice Waite of the Supreme Court sitting on circuit. His decision was later affirmed by the Supreme Court in an opinion written by the then Chief Justice Fuller, who therein stated that the clear opinion of the former Chief Justice had minimized the labors of the Supreme Court in deciding the appeal. In view of the fact that the opinions of two former chief justices of the Supreme Court uphold the contention which we are making in the instant case, we take the liberty of quoting from each.

FROM OPINION OF CHIEF JUSTICE WAITE.

“The money received by the firm from the bank was generally mingled with that which was got from other sources, and it has been impossible to trace it directly into property now in the hands of the assignees, except in the following cases:

(Here appears a schedule of some 13 items of property constituting the first class of property referred to in the ensuing paragraphs.)

“1. As to the trust resulting to the bank by reason of the wrongful and unlawful use of its funds by its officers in the purchase of property for the firm or the several members thereof, this branch of the case divides itself into two parts, the first relating to property which was purchased with moneys that can be identified as belonging to the bank; and, second, to that which was bought and paid for by the firm out of the general mass of moneys in their possession and which may or may not have been made up in part of what had been wrongfully taken from the bank.

“As to the first of these classes of property we entertain no doubt that the trust exists, and that it may be enforced by the receiver unless the assignees of Bain & Bro. occupy the position of *bona fide* purchasers for a valuable consideration without notice. . . . The evidence shows beyond doubt that the affairs of the bank were managed almost exclusively by the members of the firm. The funds of the bank were under the immediate control of its officers and agents, and consequently as its trustees. These funds were converted by them regardless of their duty as trustees into this particular property, which still exists in specie. *No money was used in these purchases other than such as was taken directly from the bank for that purpose.* Under these circumstances the property stands in the place of the money used, and it might have been reclaimed by the bank at its election any time before the rights of innocent third parties intervened. This is elementary. The receiver succeeded to the rights of the bank in this particular.

“The property in the second class, however, occupies a different position. There the purchases were made with moneys that cannot be identified as be-

longing to the bank. The payments were all, so far as now appears, from the general fund then in the possession and under the control of the firm. Some of the money of the bank may have gone into this fund, but it was not distinguishable from the rest. The mixture of the money of the bank with the money of the firm did not make the bank the owner of the whole. All the bank could in any event claim would be the right to draw out of the general mass of money, *so long as it remained money*, an amount equal to that which had been wrongfully taken from its own possession and put there. Purchases made and paid for out of the general mass cannot be claimed by the bank, *unless it is shown that its own moneys then in the fund were appropriated for that purpose*. Nothing of the kind has been attempted here, and it has not even been shown that when the property in this class was purchased, the firm had in its possession any of the moneys of the bank *that could be reclaimed in specie*. To give a *cestui que* trust the benefit of purchases by his trustees, it must be satisfactorily shown that they were *actually made with the trust funds*." (Italics ours.) (pp. 677, 678, 679.)

FROM THE OPINION OF CHIEF JUSTICE FULLER.

"The receiver assigns for error that the Circuit Court held that he was entitled to a surrender of such of the property which it was found had 'actually been purchased with the moneys of the bank as he elects to take, but of no other.' In other words, it is insisted that the receiver is entitled to a charge upon the entire mass of the estate, with priority over the other creditors of Bain & Bro.

It was said by Mr. Justice Bradley in *Frelinghuysen v. Nugent*, 34 Fed. Rep. 229, 239: 'Formerly the equitable right of following misapplied money or other property into the hands of the parties receiving it depended upon the ability of identifying it; the equity attaching only to the very property misapplied. This right was first extended to the proceeds of the property, namely, to that which was procured in place of it by exchange, purchase or sale. But if it became confused with other property of the same kind, so as not to be distinguishable, without any fault on the part of the possessor, the equity was lost. Finally, however, it has been held as the better doctrine that confusion does not destroy the equity entirely, but converts it into a charge upon the entire mass, giving to the party injured by the unlawful diversion a priority of right over the other creditors of the possessor. *This is as far as the rule has been carried.* The difficulty of sustaining the claim in the present case is, that it does not appear that the goods claimed—that is to say, the stock on hand, finished and unfinished—were either in whole or in part the proceeds of any money unlawfully abstracted from the bank.' The same difficulty presents itself here, and while the rule laid down by Mr. Justice Bradley has been recognized and applied by this court, *National Bank v. Insurance Company*, 104 U. S. 54, 67, and cases cited, yet, as stated by the Chief Justice, 'purchases made and paid for out of the general mass cannot be claimed by the bank *unless it is shown that its own moneys then in the fund were appropriated for that purpose.*' And this the evidence fails to establish as to any other property than that designated in the decree." (Italics ours.) (Pp. 693, 694.)

It will be seen that the foregoing case lays down some very definite principles and as far as the instant case is concerned some exceedingly controlling ones. Due to the fact that in that case some of the properties could be traced while the balance could not, we are afforded an excellent guide as to the principles governing the tracing of trust funds into real property. These principles may be enumerated as follows:

- (a) *The requirement that trust funds be traced into specific property in order that a trust be imposed upon the latter is met by a showing that specific trust moneys not commingled with private funds were actually used in the acquisition of the property.*

(“No money was used in *these* purchases other than such as was taken directly from the bank for that purpose.”)

- (b) *Such requirement is not met by a showing of purchases made out of a commingled fund which had been augmented at some prior time through the infusion of trust moneys.*

(“The money received by the firm from the bank was generally mingled with that which was got from other sources and it has been impossible to trace it *directly* into property now in the hands of the assignees” etc.)

- (c) *The right to reclaim trust moneys out of the balance remaining in a commingled fund, under the Hallett presumption, in no sense relieves the cestui of the necessity of actually tracing his trust moneys into properties acquired out of the commingled fund.*

(“All the bank could in any event claim would be the right to draw out of the general mass of money *so long as it remained money* an amount equal to that which had been taken from its own possession and put there.”)

- (d) *The right to reclaim out of a commingled fund conferred by the Hallett presumption in no sense extends to purchases made out of such fund. In such a case the claimant must show, in order to impress a trust upon the acquired property, that the same was actually purchased with trust moneys.*

(“Nothing of the kind has been attempted here and it has not even been shown that when the properties in this class were purchased, the firm had in its possession any of the moneys of the bank *that could be reclaimed in specie*. To give a *cestui que* trust the benefit of purchases by the trustees it must be satisfactorily shown that they were *actually made* with the trust fund.”)

- (e) *Mere proof that property has been acquired through payments made out of a commingled fund is insufficient to establish that the cestui's own money, as distinguished from that of the trustee, has been used to make such purchase. (Id.)*

We submit that the above case is unanswerable as to each of the above propositions.

The Master, however, attempted to distinguish the case on the ground that, as literally appears from the opinion, the books of the bank and of the partnership were in such a chaotic condition that the principle of “low balance”

tracing of the commingled trust moneys could not be applied. Obviously then the Master assumed that if such a tracing had been possible a contrary result would have been reached by the Supreme Court. We respectfully submit that the case itself negatives the learned Master's theory. It also negatives the basic proposition upon which the Master's ultimate holding is based and to which he cites *Peters v. Bain* as authority, namely, that where a mixed fund is traced into property the property is but a substituted form of the mixed fund. With all respect we submit that *Peters v. Bain* holds exactly to the contrary. Let us state a few pertinent expressions of the respective opinions of the two Chief Justices:

1. "The mixture of the money of the bank with the money of the firm did not make the bank the owner of the whole."

This is unquestionably a proposition which would be true whether there was a "low balance" tracing or not.

2. "All the bank could in any event claim would be the right to draw out of the general mass of money, *so long as it remained money*, an amount equal to that which had been wrongfully taken from its own possession and put there." (Italics ours.)

Here is both a recognition and a limitation upon the operation of the exception to the general rule of actual tracing laid down by the *Hallett* case.

Paraphrasing this language to fit our facts, we find that all Universal could claim in any event (a commingled fund being proven) would be the right to draw out of the general mass of money, *so long as it remained money*, an amount equal to that which had been wrongfully taken from its possession and put there. This is the only and

the utmost effect which may be attributed to the *Hallett* doctrine, whether it be regarded as an estoppel upon the trustee (which was the view taken by the Master) or as a fiction or as a presumption. In any case, it only operates as a *modus operandi* whereby the defrauded *cestui* may subject to his claim the balance of a theretofore commingled fund remaining in the hands of the trustee.

“This is as far as the rule has been carried.”

Frelinghuysen v. Nugent, supra.

Hence, when it comes to purchases of property made by the trustee out of moneys in his possession, whether there has been a comminglement or not, the exception has no application, for it, together with its rule of estoppel, impinges against and yields to the general rule requiring a strict and actual tracing of the trust moneys.

3. “. . . it has not even been shown that when the property in this class was purchased the firm had in its possession any of the moneys of the bank that could be reclaimed in specie.”

This language indicates that even if such a showing had been made there would still remain the necessity of proof that trust moneys had actually gone into the purchase of the property which is our problem here. This is made manifest by the following:

4. “To give a *cestui que* trust the benefit of purchases by his trustees, it must be satisfactorily shown that they were *actually* made with the trust funds.”
(Italics ours.)

In other words, it is quite clear from the language **above** quoted that even though a showing be made sufficient to warrant a reclamation from a fund as a fund, it

by no means follows that evidence of a purchase paid for by the moneys at such time in the fund is sufficient to warrant a finding that trust funds actually went into the property.

This is so by reason of the limitations upon the exception to the general rule which permits the reclamation from a fund only of a substituted equivalent for the trust moneys originally deposited therein. The trustee, we may say, is estopped to deny that the moneys held by him include the trust moneys. This estoppel, fiction or presumption, whatever it may be, has no operation where property is acquired by the trustee through the use of funds which, as a matter of fact, may or may not be said to include those previously entrusted to him. In such a case the general rule, rather than the exception, applies, and one who would prevail as against the general creditors of the faithless trustee must prove, as a fact, that trust moneys actually were used. There is no presumption, fiction or estoppel which is operative in such a case. The matter is purely and simply one of proof of a fact without reference to the artificial aids which, by means of the Hallett rule, may be resorted to when reclamation from a commingled fund is sought. In the instant case, we may concede that the tracing was such that at the time of any of the purchases a reclamation in specie from the fund might have been had. When it came to purchases made from the fund, however, it was incumbent upon intervener to show that trust funds *actually* and not "presumptively" or by reason of the exercise of any fiction or estoppel, went into the property acquired. There is no pretense that such a showing was made. As a matter of fact, it was practically an every day occurrence for the withdrawals from

the Richfield bank account to exceed the amount of the last prior deposit of trust moneys. In this connection the evidence indicated that approximately \$81,000,000.00 passed through the account during the period of the dealings between the two companies. [Tr. p. 98.]

Thus we find that the Master applied the rule of estoppel which is applicable only where an attempt is made to reclaim from a specific fund to a series of purchases of property where, we respectfully submit, a showing of actual and not synthetic use of the trust funds was requisite. From the standpoint of a tracing into real property, all that the record reveals is a series of purchases made from a fund in which there previously had been infused both trust and private moneys with no evidence whatever to show whether any of the trust moneys actually went into the purchase of any of the parcels of property acquired. Likewise, if we eliminate the effect of the Hallett rule there was no evidence whatever to show that there were actually any trust moneys whatever in the fund at the time of the making of any of the purchases in question.

The language used in the opinion of Chief Justice Fuller in *Peters v. Bain* likewise fully supports our contention. His citing of the case of *Frelinghuysen v. Nugent* to the point that while a confusion (or comminglement) does not destroy the equity, the result being a charge upon the entire mass, *but that this is as far as the rule has been carried*, completely illustrates the extent to which the Hallett fiction may be employed. Here, we respectfully submit, the Master, and hence the court, has carried it to a length wholly unsanctioned by the law as declared by the Supreme Court. He has sustained an asserted trac-

ing into property acquired through the use of a commingled fund upon evidence which would only have warranted a reclamation in specie from the fund itself. In the latter case, due to the exception applicable solely thereto, an actual tracing of the trust moneys is not required. In the former case an actual tracing is and always has been required and it is undisputed that the evidence in this case shows none whatever. With all respect, the conclusion of the Master that the acquired property stands as the trust property in a substituted form wholly begs the question. Before this can be said the trust moneys must be shown to have been used in its acquisition. No such showing was made.

Another decision of the Supreme Court which in principle negatives the Master's theory is that of *Schuyler v. Littlefield* (1913), 232 U. S. 707, 712. In that case Brown & Co. obtained from plaintiff by fraud certain Interborough stock of a value of \$9600.00. That stock, together with others aggregating in value \$289,600.00, was sold by Brown & Co. to Miller, who paid for it with two checks, one for \$266,600.00 and the other for \$23,000.00. Brown & Co. failed. Their check to plaintiff for the Interborough was denied payment and plaintiff then sought either to reclaim from the Brown & Co. bank account or to impress a trust upon certain stocks asserted by plaintiff to have been acquired from that bank account with the proceeds of the Miller checks. Both forms of relief were denied.

As to the claimed right to impress a trust on the stocks acquired, the Supreme Court held that not only was there doubt as to when the Miller checks were deposited in the Brown & Co. account (as it was closed at or about

the time of such deposits) but also that even if it be deemed that the checks had been deposited so as to have been used prior to the closing of the account, no sufficient showing had been made as to the *particular use* to which the proceeds of these checks had been devoted. We quote from the opinion as follows:

“The appellants, however, presented their case in a double aspect. They contended that even if the trust fund of \$9,600 was checked out of the bank they are able to trace the fund into stocks that subsequently came into the hands of the Trustee in Bankruptcy. This was based on the claim that out of the proceeds of the Miller checks, Brown & Co. had paid notes due to the bank and thereby released collateral which ultimately came into the possession of the Trustee.

But the record fails to show when the \$266,600 was deposited and it also fails to show with the *requisite certainty* the particular use made by Brown & Co. of that money. The banking transactions on August 24th involved several millions of dollars. Money was deposited by Brown & Co. in the bank and money was borrowed by Brown & Co. from the bank. Part of the loans were deposited to their bank account and a part, represented by cashier's checks, did not appear in that account. Money was paid by Brown & Co. to outsiders and to the bank. Payments to the bank were made on accounts of notes, some of which represented loans appearing in the deposit account, and others represented loans which had not been so entered. Some of the loans were secured and others were unsecured, and whether the money received from Miller (which included the trust fund of \$9,600), was used to pay the secured or unsecured loans *does not appear with certainty*.

It would serve no useful purpose to make a detailed statement of the testimony. The evidence has been fully discussed by the Court of Appeals (193 Fed. Rep. 24-33) in considering this claim of appellants along with that of several other parties seeking, on somewhat similar facts, to trace trust funds into the bank and thence into collateral which ultimately came into the hands of the Trustee. All these claims were disallowed because of the failure to make the requisite proof. Our investigation of the facts leads us to the same conclusion so far as concerns the appellants' claim. They were practically asserting title to \$9,600 said to have been traced into stock in the possession of the Trustee. Like all other persons similarly situated, they were under the burden of proving their title. If they were unable to carry the burden of identifying the fund as representing the proceeds of their Interborough stock their claim must fail. If their evidence left the matter of identification in doubt the doubt must be resolved in favor of the Trustee, who represents all of the creditors of Brown & Co., some of whom appear to have suffered in the same way. Like them the appellants must be remitted to the general fund." (Italics ours.)

The above holding is significant when we consider the stress laid by the Supreme Court as to the necessity of showing with requisite certainty, the particular use to which the asserted trust moneys had been devoted.

Appellee has heretofore attempted to distinguish *Schuyler v. Littlefield* and as well the decision of the case

in the Circuit Court of Appeals (sub nom *in re* Brown, 193 Fed. 30, C. C. A. 2nd, 1912) by asserting in effect that inasmuch as *all* of the claimants were *cestuis que trustent* "a higher degree of proof is required because a claimant must show some reason why he should be entitled to a preference over one standing in the same position as he is." This assumption was entirely gratuitous and was advanced wholly without citation of authority to support it. True, there were several trust claimants in the fund which arose upon the unhappy demise of Brown & Co. (see *In re A. O. Brown & Co.*, 193 Fed. 24), but this did not mean that Brown & Co. had no general creditors. That the contrary was the case is made apparent by the very language in *Schuyler v. Littlefield*, where, in laying down a rule which has direct application to the instant case, the Supreme Court stated:

"If their evidence left the matter in doubt the doubt must be resolved in favor of the trustee who represents *all* of the creditors of Brown & Co., *some* of whom appear to have suffered in the same way."

Moreover, it is quite apparent from reading any or all of the three decisions dealing with the misfortunes of Brown & Co. that neither the Supreme Court nor the Circuit Court of Appeals based their holding of insufficient tracing upon any such theory as that advanced by intervenor. In any case and irrespective of whether others occupy the same position, one seeking to establish a trust must trace the property or its proceeds. No other conclusion may be drawn when we find precisely the same rule

of tracing followed in the Brown & Co. cases as had previously been declared in *Peters v. Bain*, where there did not appear to have been any trust claimants other than the bank receiver. It follows, therefore, that in addition to the principles for which the *Bain* case stands as authority, we are indebted to *Schuyler v. Littlefield* for the following:

(f) *In order that a claimant establish a trust against property purchased or otherwise acquired out of a commingled fund through the asserted use of trust funds, the burden is upon the claimant to prove with certainty that his money actually went into property so acquired.*

(g) *Even if it be shown that a deposit which actually included trust moneys was made in an active bank account, mere proof of the acquisition of property through withdrawals from that account is insufficient to trace the trust moneys into the property so acquired.*

This last principle is especially applicable to the facts of the instant case. It will be recalled that enormous sums were daily deposited in and withdrawn from the Richfield bank account during the period involved herein.

We, therefore, respectfully submit that the evidence merely reveals that the general assets coming into the hands of the receiver were indirectly augmented by the amounts received from Universal, and that there was in no sense any actual tracing of such amounts into any specific properties. It has been universally held that such a showing is insufficient.

3. **A Mere Showing That Trust Funds Have Gone to Swell the Assets of an Insolvent Is Insufficient to Impress a Trust Upon Properties Acquired Through the Use of the General Funds of the Insolvent With Which the Trust Funds Have Been Blended.**

The above rule is universally declared by the federal and most of the state decisions. Thus in *Board of Commissioners v. Strawn*, 157 Fed. 49 (C. C. A. 6, 1907) we find the following statement (page 54):

“But aside from this view of the evidence, the claim to a general charge upon any and all property acquired by the bank, through the use of the general funds of the bank with which this trust fund had been blended, is not supported by the weight of authority, nor do the cases decided by this court go so far. That the misuse of this trust fund has gone to swell, in one form or another, the general assets of the bank is not enough to charge the whole with a lien, will not be seriously contested. The cases which deny such a contention are numerous.”

The above principle is reiterated in *Empire State Surety Co. v. Carroll County*, 194 Fed. 593 (C. C. A. 8, 1912), in the following language (page 604):

“It is indispensable to the maintenance by a *cestui que trust* of a claim to preferential payment by a receiver out of the proceeds of the estate of an insolvent that clear proof be made that the trust property or its proceeds went into a specific fund or into a specific identified piece of property which came to the hands of the receiver and then the claim can be sustained to that fund or property only and only to the extent that the trust property or its proceeds went into it. It is not

sufficient to prove that the trust property or its proceeds went into the general assets of the insolvent estate and increased the amount and the value thereof which came to the hands of the receiver. *Peters v. Bain*, 133 U. S. 670, 693, 694, 10 Sup. Ct. 354, 33 L. Ed. 696; *Spokane County v. First Nat. Bank*, 68 Fed. 979, 982, 16 C. C. A. 81, 84; *Board of Com'rs. v. Patterson (C. C.)* 149 Fed. 229; *Frelinghuysen v. Nugent (C. C.)* 36 Fed. 229, 239; *Board of Com'rs. v. Strawn*, 157 Fed. 49, 51, 84 C. C. A. 553, 555, 15 L. R. A. (N. S.) 1100; *Lowe v. Jones*, 192 Mass. 94, 101, 78 N. E. 402, 6 L. R. A. (N. S.) 487, 116 Am. St. Rep. 225, 7 Ann. Cas. 551; *Cherry v. Territory*, 17 Okl. 213, 89 Pac. 190; *St. Louis Brewing Ass'n. v. Austin*, 100 Ala. 313, 13 South. 908; *Little v. Chadwick*, 151 Mass. 109, 23 N. E. 1005, 7 L. R. A. 570; *Howard v. Fay*, 138 Mass. 104; *Attorney General v. Brigham*, 142 Mass. 248, 7 N. E. 851; *Erie Ry. Co. v. Dial*, 140 Fed. 689, 72 C. C. A. 183; *Ferchen v. Arndt*, 26 Or. 121, 37 Pac. 161, 29 L. R. A. 664, 46 Am. St. Rep. 603; *Blake v. State Savings Bank*, 12 Wash. 619, 41 Pac. 909, 910; *In re North River Bank*, 60 Hun. 91, 14 N. Y. Supp. 261; *Williams v. Van Norden Trust Co.*, 104 App. Div. 251, 257, 93 N. Y. Supp. 821; *Bishop v. Mahoney*, 70 Minn. 238, 73 N. W. 6; *Nonotuck Silk Co. v. Flanders*, 87 Wis. 237, 58 N. W. 383; *Burnham v. Barth*, 89 Wis. 362, 366, 62 N. W. 96; *Bradley v. Chesebrough*, 111 Iowa, 126, 82 N. W. 472; *Lebanon Trust & Safe Deposit Bank's Assigned Estate*, 166 Pa. 622, 31 Atl. 334; *Marquette Fire Com'rs. v. Wilkinson*, 119 Mich. 655, 670, 78 N. W. 893, 44 L. R. A. 493; *Hauk v. Van Ingen*, 196 Ill. 20, 39, 63 N. E. 705; *Ellicott v. Kuhl*, 60 N. J. Eq. 333, 46 Atl. 945; *Ober v. Cochran*, 118 Ga. 396, 45 S. E. 382, 98 Am. St. Rep. 118; *In re Mulligan (D. C.)* 116 Fed. 715,

717, 718; *Holmes v. Gilman*, 138 N. Y. 369, 376, 34 N. E. 205, 20 L. R. A. 566, 34 Am. St. Rep. 463; *In re Hicks*, 170 N. Y. 195, 198, 63 N. E. 276.”

The case of *In re Brown*, 193 Fed. 24 (C. C. A. 2, 1912), to which we have heretofore made reference, is interesting in this connection. Not only does it negative the theory that a superior equity does away with the necessity of proof of the tracing but it also places the burden of proof where it belongs, which is to say, upon the claimant. It also follows the main principle under discussion with reference to proof of a mere augmentation of assets being insufficient. We quote (page 28):

“As we have seen, the Hanover Bank had in its possession various surpluses of collaterals above the amount of the several notes for which such collateral was pledged, *some of these collaterals were paid for by checks drawn on the Hanover Bank and paid on the 24th*, and it is contended that a lien for the trust funds is established against the surpluses of collaterals so purchased. *But there is nothing to trace claimant’s money into any particular stocks or bonds, or into the collateral put up against any particular loan.*

“It was said in *Smith v. Mottley*, 150 Fed. 268, 80 C. C. A. 154, that:

“‘In the absence of proof to the contrary, the reception of the funds being so near to the assignment by the bank, it may be presumed that the assets which came to the hands of the trustee were augmented by the proceeds of the check’—which check in that case was the thing converted.

“Thus baldly stated the quotation might seem to support the theory that the beneficiary would have a lien on property which came to the trustee because

the bankrupts, had they not misused the trust fund, would have had to borrow that additional sum from their banks on the collateral they had with them covering their various notes, and therefore the banks would have paid themselves out of such collateral, and the trustee in bankruptcy would not have obtained so much from them. The same court which decided *Smith v. Mottley*, however, subsequently held, in *Board of Commissioners v. Strawn*, 157 Fed. 49, 84 C. C. A. 553, 15 L. R. A. (N. S.) 1100, that *the mere fact that the misuse of a trust fund has gone to swell, in one form or another, the general assets of a bankrupt, is not enough to charge a lien on such assets; and that, to impress a trust upon the property of a tort-feasor who has used the trust fund in his private affairs, it must be traced in its original shape or substituted form.* We fully concur in this statement of the law. No doubt the individual whose property has been converted has a high equity and is entitled to certain well-settled presumptions; but we cannot assent to the proposition that he may trace his money into any specific fund or security *merely by inferences based on presumptions* without substantive testimony to sustain them. *The burden of proof is on the claimant at the outset; it rests upon him at the close of the case.* If he has not, then, upon the whole proof, made clear the final resting place of his converted property or its substitute, he cannot sustain his claim." (Italics ours.)

The facts to which the foregoing principles were applied are especially relevant here. The proceeds from the claimant's converted stock, \$2037.50, had been deposited in the account in the Hanover Bank, thus paralleling our facts. Prior to the closing of the account certain collaterals were purchased therefrom, again paralleling our

facts. Moreover it was assumed in support of the conclusion of the trial court that the "low balance" of the account exceeded the amount of the trust moneys up to the time of the purchase of the collateral. Upon this showing, if the Master's position is correct, a trust should have been declared upon purchases from the bank account prior to the closing thereof, not exceeding the above mentioned sum. On the contrary, however, the court concurred with the holding of the District Court that any proceeds of claimant's stock which might have been in the account were dissipated by the certification of a check which wiped out the account on the day *after* the collaterals were acquired and that the proceeds could be traced no further for this reason.

It will be seen that the above case merely follows the principles of *Peters v. Bain*. *So long as the commingled fund remains money* the claimant may seek recovery against the residue subject to low balance principles and in accordance with the fiction of *Knatchbull v. Hallett*. Where, however, a claimant merely shows purchases out of a commingled fund which has later been dissipated, he has merely shown an augmentation of assets without the necessary adjunct of a tracing into the property acquired.

In this connection appellee has heretofore cited *Schumacher v. Harriett*, 52 Fed. (2d) 817 (C. C. A. 4, 1931) and *Ellerbe v. Studebaker Corp.*, 21 Fed. (2d) 993 (C. C. A. 4, 1927) to the effect that trust funds may be recovered from a receiver if they have gone to augment the assets passing through the receiver's hands. This was a rather left-handed way of stating the holdings in these two cases. Their true effect is perhaps epi-

tomized by the following quotations from the *Schumacher* case (page 818, page 819):

“The rule is well settled that where property or funds which are the subject of a trust are used by a bank in such way as merely to decrease its liabilities and not to augment its assets, no charge upon the assets arises in favor of the *cestui que trust*. *Ellerbe v. Studebaker Corporation of America* (C. C. A. 4th) 21 F. (2d) 993; *First National Bank of Ventura v. Williams* (D. C.) 15 F. (2d) 585; *City Bank v. Blackmore* (C. C. A. 6th) 75 F. 771.

* * * * *

“As the fund upon which the trust is asserted in this case is the fund of cash and cash items which passed into the hands of the receiver, the question in the case is whether the \$8,500 of plaintiff has been traced into that fund; for it is settled that *it is not sufficient merely to prove that the trust property went into the general estate and increased the amount and value thereof which came into the hands of the receiver*. *Empire State Surety Co. v. Carroll County*, *supra* (C. C. A.) 194 F. 593 at page 604, and cases there cited.” (Italics ours.)

So considered, it will be seen that the two decisions in question really stand for the proposition that where the trust funds have been used to decrease liabilities a trust may not be declared upon the general assets. On the other hand where the trust funds have been used to augment the assets (cash) and can be traced into those assets, a recovery against the fund will be allowed. We do not quarrel with this proposition which in no way affects the principle that strict tracing is required where it is sought

to fasten a trust upon real property acquired out of commingled funds.

Since appellee still asserts, we assume, that purchases made out of a commingled fund are *ipso facto* chargeable with the same claim which might have been asserted against the fund itself, it behooves us to analyze the decisions which it has heretofore cited to this point.

4. Purchases Made Out of a Commingled Fund Are Not *Ipsa Facto* Chargeable With a Trust.

The following federal cases were cited by appellee in support of the proposition that "if funds misappropriated by a trustee are commingled with his own funds, property in which the commingled funds are invested is subject to a lien in favor of the *cestui*."

- (1) *In re J. M. Acheson Co.*, 170 Fed. 427, 429, (C. C. A. 9, 1909).

In this case the court was dealing with the sufficiency of a petition for a preferred claim in bankruptcy which had been disallowed. The petition directly alleged that the trust funds had been used, among other things, in acquiring assets which had come into the hands of the trustee. Inasmuch as the petition directly charged the use of the trust funds in acquiring the property in question it was clearly sufficient. The pronouncements of the opinion with regard to the matter of proof to be made at subsequent hearings also support our position here. The decision states that

"The owner must assume the burden of ascertaining and tracing the trust funds, showing that the assets which have come into the hands of the trustees

have been *directly added to or benefited* by an amount of money realized from the sales of the specific goods held in trust," (Italics ours)

which is eminently correct. Such a showing would, of course, necessitate a tracing of the trust funds into the goods or property coming into the hands of the trustee upon his appointment. Then, says the opinion, the burden devolves upon the trustee to distinguish between "what is his and that of the *cestui que trust*." In other words, if the claimant makes a *prima facie* showing of tracing the moneys into the goods, then the burden is on the trustee, if he can, to repudiate such showing. Obviously, if no proof were offered by the trustee in such a situation the claimant would be entitled to a decision in his favor. It will readily be seen, however, that in the instant case appellee never reached a position which necessitated such rebuttal evidence, for it made no attempt whatever to trace from the commingled fund into the acquired property and thus never reached a point where it could rest its case and be relieved of the burden of going forward.

It will be realized immediately that appellee seeks to avail itself of the rule with regard to the shifting of the burden of going forward declared in the case last cited without in the least heeding the requirement that before the rule may be deemed applicable the claimant must have made a *prima facie* showing of a tracing. It takes the position that upon a mere showing that trust funds were commingled with the general funds of Richfield the burden immediately devolved upon those resisting the claim to show that purchases out of the commingled fund were *not* made with trust funds. In this way it ingeniously seeks to avoid the troublesome matter

of tracing the trust funds into the assets coming to the hands of the receiver which is, under the very case it cites, a burden which it and it alone must assume. Were it merely seeking to reclaim from the commingled fund then a *prima facie* showing would be made upon mere proof of the comminglement of moneys, as the case of *American Surety Co. v. Jackson*, 24 Fed. (2d) 768 (C. C. A. 9, 1928) cited by it and later discussed herein clearly shows. In a situation of that sort the presumption of the *Hallett* case comes into play and it will be presumed that the balance remaining in the fund is composed of trust moneys unless (and here the burden is upon the trustee) it can be shown that the trust moneys had actually been dissipated. We have no such situation in the present case. It would only be paralleled by the facts here if appellee had actually made a showing that actual trust moneys had been used to purchase the acquired properties. This showing having been made, it would then have devolved upon those resisting the claim to controvert such showing if they could, but it will be clearly perceived that appellee rested far short of such a *prima facie* position as this.

(2) *City of Spokane v. First National Bank of Spokane*, 68 Fed. 982 (C. C. A. 9, 1895).

Here again the sufficiency of a pleading was under consideration. The court construed the "averments of the bill to distinctly allege that the assets which came into the hands of the receiver were purchased by the bank with the city's money." Manifestly the bill was sufficient. Whether or not the city would have been able to trace the trust fund into the acquired assets by proof was quite another matter which the court quite properly refrained

from passing upon. It is significant that in the companion case of *Spokane County v. First National Bank*, 68 Fed. 979, where the averments which form the basis of the holding in the city's case were omitted, the court stated, in affirming the decree of dismissal on demurrer (page 982):

“Both the settled principles of equity and the weight of authority sustain the view that the plaintiff's right to establish his trust and recover his fund must depend upon his ability to prove that his property is in its original or a substituted form in the hands of the defendant.”

Kemp v. Elmer Co., 56 Fed. (2d) 657 (D. C. S. D. Cal., 1932).

The opinion in this case concerned the admissibility of certain evidence which, the court held, indicated that all of the assets of the Elmer Company consisted of moneys or the fruits thereof embezzled by Beesemyer from the Guaranty Building and Loan Association. Since, under these facts, all of the assets of the Elmer Company had been indisputably acquired with trust moneys the tracing was complete. There was no question of purchases out of a commingled fund in the case.

Equitable Trust Co. v. Conn. Brass & Manuf. Co., 10 Fed. (2d) 1913 (C. C. A. 2, 1926).

In this action the United States had delivered some 2,000,000 pounds of raw copper to defendant which had intermingled it with its own metal. Some 700,000 pounds of the commingled copper came into the possession of the defendant's receiver. The court held quite properly that the United States was entitled to withdraw its equivalent amount of copper from the commingled mass. This situa-

tion would be paralleled in our case if appellee were seeking to reclaim from a commingled fund coming into the hands of the receiver rather than attempting to trace *out* of such a fund subsequently dissipated.

Southern Cotton Oil Co. v. Elliotte, 218 Fed. 567,
(C. C. A. 6, 1914).

The bankrupt had borrowed money from the claimant for the express purpose of buying cotton seed and shipping it to plaintiff. At the time of the bankruptcy certain seed purchased by the bankrupt had been delivered to the claimant's warehouse. Although it appeared that some of this seed had been obtained otherwise than through the use of the claimant's money, the court held primarily that the evidence was sufficient to fix the general character of the mass as having been purchased directly with claimant's funds, laying some stress upon the doctrine of tortious confusion. The case is, of course, easily distinguishable. Where the asserted trustee agrees to divert moneys received to a particular use and it is later ascertained that the trustee has diverted moneys to such use, a presumption the converse of that in the *Hallett* case would naturally seem to arise that the *cestui's* moneys and not the trustee's were used therefor. This situation could only have arisen in our case if Richfield had specifically agreed to use the Universal moneys for the purpose of acquiring the various properties involved. Under such an agreement Richfield would have had considerable difficulty in establishing that the purchases had been made

for its own account rather than in performance of its trust. The case is of no assistance here by reason of the divergent nature of its underlying facts.

Smith v. Town of Au Gres, 150 Fed. 258 (C. C. A. 6, 1906).

In this case the bankrupt openly admitted that he had used moneys of the township to the extent of \$4400.00 in his own private business. The admissions were held competent and hence the evidence clearly showed a tracing into the assets which came into the hands of the trustee. For this reason the case begs the question under discussion here.

The same court which decided the *Au Gres* case later distinguished it not only upon this ground but upon the further ground that cases involving stocks of merchandise are *sui generis* as compared with those involving an attempt to impress a trust upon separate and distinct pieces of property (in that case, distinct pieces of commercial paper). We quote from *Board of Commissioners v. Strawn, supra* (page 57):

“In the *Au Gres* case it was shown that a township treasurer had used the public funds in his hands in buying additional merchandise, and adding the same to his stock as a general merchant. He became bankrupt, and this stock of merchandise thus augmented went into the possession of the trustee. The particular items which had been paid for and added to the general stock were not ascertainable, but this court held that the misappropriated trust fund, having been traced into the general stock, constituted a prior lien and charge upon the stock as a unit. This case proceeds upon the theory that a stock of merchandise constitutes a subject which is capable of

being sold or mortgaged as an entirety, and in the latter case the mortgage is not invalid if it provides for a continuance of the business, merchandise added from time to time to take the place of that sold passing under the mortgage. It is quite distinguishable from the case at bar, where it is sought to fasten a trust fund upon hundreds of distinct pieces of commercial paper made by many different persons and acquired at different times, because it is probable that some of such bills or notes were acquired with the general funds of the bank with which had been mingled some part of complainants' tax deposits." (Italics ours.)

In addition to the foregoing it is interesting to note that in the *Strawen* opinion (page 54) the court characterizes the *Au Gres* case as one of the

"cases decided by this court, which recognize that the mere misapplication of a trust fund does not create a general lien upon the tort-feasor's estate. In other courts, the question has been presented more squarely for a decision, and supports the rule that an identification of the fund itself, or *a tracing into some specific property*, is essential to reach the property of a wrongdoer, either in the hands of an assignee, trustee, receiver, or under a lien fastened by a creditor. *Peters v. Bain*," etc. (Italics ours.)

Appellee also cited *American Surety Company v. Jackson*, 24 Fed. (2d) 758 (C. C. A. 9, 1928) in support of its contention that while the burden is on the *cestui* to trace the funds and establish his claim thereto by clear and satisfactory proof nevertheless the burden shifts, once the receipt of trust funds by the asserted trustee is shown. As we have pointed out above, this contention would be

well founded were appellee going no further than to assert its rights as against the fund into which the money is traced, which was the precise situation in the *Jackson* case. The court in that case merely held that the Hallett doctrine was a mere fiction, that it had been approved and followed "in many subsequent cases when the trust fund has consisted of moneys on deposit," and that in such a case to avoid the application of the fiction the trustee must show, if he can, that the trust moneys were dissipated so as not to be deemed to be in the fund remaining. We have no quarrel with this principle if limited to its proper scope. Where, however, it is sought to impress a trust upon properties purchased *out* of a fund, the logic of this very principle demands that the *cestui* then trace, if he can, the trust funds into the acquired property. Then, and not until then, is the trustee called upon to combat this showing precisely as stated in *In re J. M. Acheson & Co., supra*.

From the combined effect of these cases, both decided in the 9th Circuit, we may draw the following principle with regard to the matter of burden of going forward.

(h) *In applying the principle that the claimant must trace the asserted trust fund and establish his claim to the same or its proceeds by clear and satisfactory proof, the burden of going forward never shifts until the claimant has actually introduced evidence which, if not controverted, would support a finding that the trust res in whole or in part actually went into the fund or specific piece of property sought to be charged.*

From *Peters v. Bain* and kindred cases heretofore cited by us the following corollary to the above we submit is correct:

(i) *A mere showing that purchases of property have been made out of a fund in which prior thereto trust funds had been commingled with funds of the asserted trustee, is not sufficient to support a finding that the trust res in whole or in part actually went into the properties sought to be charged. Hence, in such a case the showing made by the claimant is insufficient to shift the burden of going forward to the asserted trustee.*

The above conclusions are in no way contradicted but rather are aided by the cases cited by appellee to which we have above made reference. In view of the fact that the federal courts have clearly announced the rules applicable to situations of the kind involved herein and have declared them to be matters in which they will not be bound by state decisions, we feel that it would in no way aid the court were we to undertake an analysis of the various state decisions cited by appellee to the points under discussion herein. In so far as the state decisions follow the rules declared by the federal courts a review of them is unnecessary. To the extent that some of them may differ and follow other tests in situations held by the federal courts to require an actual tracing, they are clearly irrelevant. As an actual fact the case of *Peters v. Bain* is determinative of this entire controversy for its rule of a strict tracing in cases of property purchased out of a commingled fund has never been deviated from by the Supreme Court of the United States.

5. The Principle of *In re Oatway* Has Never Been Followed in the Federal Courts to the Extent of Doing Away With the Strict Tracing Principle in Cases Dealing With the Acquisition of Real or Personal Property Out of a Commingled Fund.

Some stress was laid by the Master upon the decision of *In re Oatway* (1903), 2 Ch. D. 356, holding that where a trustee has invested the commingled funds in property (there stocks) and dissipated the balance, he may not asert that the property was acquired by his own money and that it was the *cestui's* money which was dissipated. This it will be seen is practically the converse of the Hallett rule. In effect it is a species of estoppel which prevents the trustee from claiming the benefit of the Hallett fiction. It may be conceded that the *Oatway* decision is declaratory of the law in England today.

But when we attempt to apply the principle of the *Oatway* decision to cases arising under the jurisdiction of the United States courts we are immediately beset with difficulties arising out of the strict tracing rules which the federal courts have invariably followed in cases of this nature. The *Oatway* case, it will have been perceived, does away with all pretense of tracing from the commingled funds into the acquired properties. In so doing it immediately runs foul of the definite holding of the Supreme Court of the United States in *Peters v. Bain* and *Schuyler v. Littlefield*, where a strict tracing was insisted upon before a trust might be impressed upon acquired property. It is also apparent that in each of the latter cases the Supreme Court was confronted by the same factual situation as that dealt with it the *Oatway* case, namely, properties (in the one case realty, in the other personalty) acquired by faithless trustees out of a

commingled fund which had later been dissipated. Moreover, a further fact should not be lost sight of, namely, that *Schuyler v. Littlefield* was decided in 1913, ten years after the decision in the *Oatway* case. From this situation but one conclusion may be drawn, namely, that the law as declared by the Supreme Court of the United States, both before and after the decision in the *Oatway* case, definitely requires an actual tracing of trust moneys when the acquisition of property, real or personal, by a trustee is concerned. From this it will be seen that the instant case is decidedly not one where speculation might be indulged in as to what the Supreme Court would do were it to be confronted with facts akin to those in the *Oatway* case. It has already been confronted with those facts, not once but twice, and has positively declared that an actual, as distinguished from a synthetic or fictional, tracing is required.

The reasons why the Supreme Court has not chosen to declare or follow the *Oatway* rule do not particularly concern us here. Yet one of these reasons may have been voiced by Judge Sanborn of the Circuit Court of Appeals for the 8th Circuit in *Empire State Surety Co. v. Carroll County*, *supra*, decided in 1912, nine years after the *Oatway* decision, when he stated:

“Proof that a trustee mingled trust funds with his own and made payments out of the common fund is a sufficient identification of the remainder of that fund coming to the hands of the receiver, not exceeding the smallest amount the fund contained subsequent to the commingling (*Board of Com'rs v. Strawn*, 157 Fed. 49, 51, 84 C. C. A. 553, 555, 15 L. R. A. (N. S.) 1100; *Weiss v. Haight & Freese Co.* (C. C.) 152 Fed. 479; *American Can Co. v.*

Williams, 178 Fed. 420, 423, 101 C. C. A. 634, 637), as trust property, because the legal presumption is that he regarded the law and neither paid out nor invested in other property the trust fund, but kept it sacred (Board of Com'rs v. Patterson (C. C.) 149 Fed. 229, 232; Spokane County v. First National Bank, 68 Fed. 979, 16 C. C. A. 81).

“For the same reason the legal presumption is that promissory notes, bonds and other property coming into the hands of the receiver were not procured by the use of, and are not, trust property. Spokane County v. First Nat. Bank, 68 Fed. 979, 980, 16 C. C. A. 81, 82.” (Italics ours.)

Such a conclusion is by no means an unnatural one. If the legal presumption in one case is that a trustee would not invest the trust moneys, it should be in another. Presumptions are not to be turned on or off like water from a tap. In the absence of proof of some sort as to what was done with the trust funds (and in the *Oatway* case there was none), it may well have been that the Supreme Court, having adopted the Hallett rule, felt that the “reversible presumption” advocated by the Chancery Division was straining things a bit too far. At any rate one fact is certain and that is that the *Oatway* principle does not stand as the law as declared by the Supreme Court of the United States.

The Master seemed to feel that the federal courts have followed the *Oatway* rule, referring specifically to *In re Pacat Finance Corporation*, 27 Fed. (2d) 810 (C. C. A. 2, 1928) and *Brennan v. Tillinghast*, 201 Fed. 609 (C. C. A. 6, 1913). It is true that the *Oatway* decision was cited in these two cases but it cannot be said that it was “followed”, as far as our problem is concerned. More-

over, the circumstances which called for reference to it in the cases in question were hardly such as to afford interveners any comfort in the present matter. It must be borne in mind that we are here dealing with an attempt to follow trust moneys assumedly embodied in a commingled fund into specific items of property acquired by purchase from such fund, which was precisely the situation passed upon in *Peters v. Bain* and *Schuyler v. Littlefield*. In the *Pacat* and *Brennan* cases a portion of the commingled fund was set apart and commingled with other funds of the person against whom the trust was sought to be declared. In other words, *the money still remained money* and hence we find that the only effect of the two decisions in question was to apply the ordinary doctrine concerning trusts as to *commingled funds*. In no sense did either of the cases have anything whatever to do with the question of tracing trust moneys into properties acquired by the trustee. A brief reference to the facts in these cases will clearly demonstrate that they only go to the point of holding that a withdrawal from a commingled fund which is directly traceable to another fund equally under the control of the asserted trustee amounts but to a further commingling and that, therefore, both funds as a whole are subject to the right to reclaim. Clearly the principle of the *Oatway* case has little or nothing to do with such a situation as this.

In the *Brennan* case an insolvent bank wrongfully sold plaintiff's collateral and deposited the proceeds in another bank. (Commingling No. 1.) The insolvent then drew certain drafts against this account which were paid by the drawee to the insolvent in cash, the money remaining in the insolvent's vaults. (Commingling No. 2.) In holding that a trust might be declared against this cash later

coming into the hands of the receiver for the insolvent bank the court first referred to the Hallett presumption that the sums first drawn out should be deemed to be those which the tort-feasor had a right to expend in his own business and then stated as follows, citing the *Oatway* case in support (page 614):

“And it is furthermore clear that this rule of presumption has no application where the evidence shows that the first moneys drawn out of the mingled fund by the tort-feasor were not in fact dissipated by him at all, *but were merely transferred, in a substituted form, to another fund retained in his own possession.* In such case, it must be held that the trust attaches to the substituted form in which the property is retained by the tort-feasor, and that the right to follow the trust in such form is not lost by reason of the fact that the tort-feasor thereafter draws out and spends for his own purposes the balance of the fund in which the trust money was originally mingled.” (Italics ours.)

In the *Pacat* case the trust moneys were paid over to the bankrupt and by him deposited in his bank account. (Commingling No. 1.) The bankrupt then drew on this account and deposited the amount withdrawn to his credit in Italian money with a foreign banking house. (Commingling No. 2.) In its opinion the court stated (page 814) that it regarded lire credits as *cash in bank*. The *Oatway* doctrine was applied solely as a substitute for a dollar for lire identification of the moneys involved in the second transfer of funds.

When these two cases are analyzed it will of course be apparent that their only effect is to apply the doctrine of following into commingled funds to a situation where a

portion of the commingled fund is withdrawn and likewise mingled with another fund equally subject to the control of the party against whom the trust is asserted. While such a process theoretically involves a further dilution of the trust moneys it is not an unreasonable application of the tracing doctrine as heretofore applied to a commingled mass. The money still remains money and it is still in a fund under the control of the wrongdoer.

Clearly the two cases in no way alter the requirement which exists to this day in the federal jurisdiction that an actual tracing is required when real property purchases are involved. This same requirement likewise forbids the use of the two cases in question as authority for any claim that the standards of tracing into acquired real or personal property have in any way been changed. As we have seen, the Supreme Court has definitely declared that the standards in question have not changed.

When these considerations are taken into account it becomes reasonably apparent that the citation of the *Oatway* case in the two decisions to which we have made reference was wholly unnecessary. In the *Pacat* case, instead of simply declaring the principle that the new fund, due to direct infusion of moneys from the old, became subject to the charge upon the latter, the court apparently sought unnecessary justification for dispensing with proof of the tracing. This itself is silent but potent evidence of the fact that the court in question was rather strongly convinced either of its necessity or of the necessity of some adequate substitute therefor. Whether the *Oatway* case afforded a plausible basis for the court's position, however, remains to be seen. As a matter of fact the *Oatway* principle was not applicable to the facts of the *Pacat* case for a very obvious reason. The *Oatway*

doctrine is predicated upon (1) investment out of the commingled fund, and (2) dissipation of the balance. *In the Pacat case the commingled fund was not dissipated.* We quote (page 813):

“At the time of bankruptcy a considerable balance remained in this account but Bernardini (the claimant) has expressly disclaimed any interest in this balance, all of which has been reclaimed by others. See *In re Pacat Finance Corporation, supra.*”

The latter case is reported in 295 Fed. at page 394 and on page 408 it appears that the amount on deposit in the Pacat bank account at the time of bankruptcy was the sum of \$198,589.46. Since the amount of the trust funds advanced by claimant only approximated some \$26,000.00, certainly no dissipation of the fund was shown within the meaning of the *Oatway* decision.

A reasonable analysis of the *Brennan* case likewise shows that the *Oatway* principle was thrown in as a mere gratuity. The case held, first, that the first moneys drawn from the commingled fund were merely transferred in a substituted form to another fund retained in the possession of the wrongdoer and, second, that the trust attached to the form in which the transferred moneys were held. This, and no more, was the true import of the decision. The court then stated that under the *Oatway* decision the right to follow the money into the transferred fund was not lost because the balance in the first account was later dissipated. Obviously if, as the court held, the transfer from one fund to the other carried the trust with it, nothing that happened afterward could affect the right to pursue the trust moneys into the second fund. ...

We, therefore, submit that no weight whatever should be attached to either the *Brennan* or the *Pacat* cases. They have nothing whatever to do with the matter of tracing asserted trust moneys into acquire properties. At the very most they permit funds in which trust moneys have been commingled to be followed from one pocket of the trustee to the other, which has nothing to do with tracing into real property. Even, however, if we assume the worst and take the view that each of the cases in question lent sanction through their citation of the *Oatway* case to the principle that a tracing into real property is shown merely by proof of purchases out of a commingled fund, coupled with a later dissipation of the balance, they would still be valueless as authority in view of the fact that the Supreme Court, not once, but twice has held directly to the contrary.

In addition to the decisions which we have discussed above, a number of cases in the various state courts have been referred to by appellee as tending to do away with the necessity of actual tracing, which has been stressed by the federal courts in cases involving attempts to trace the commingled funds into real property. As we have pointed out above, this case must be decided upon the rules declared by the federal courts and the agreement or disagreement of the various state courts as to those rules is not a matter of especial materiality in this proceeding. What we have said applies as much to the California case of *Mitchell v. Dunn*, 211 Cal. 129, as to cases from other state jurisdictions. As a matter of fact, *Mitchell v. Dunn*, does not purport to follow the *Oatway* rule, although it will be conceded that in effect it attains the same result. The decision of the Supreme Court in that case was based largely upon the fact that the rights of general creditors

were not involved, and, further, upon the application of the principles of *People v. California Safe Deposit Company*, 175 Cal. 756, which refused to follow the Hallett presumption in the case of a trust *ex maleficio*, a principle which would offer serious difficulties to intervener's theory of tracing in the present case.

We next come to a consideration of the question raised by the cross-appeal of Universal herein, namely, that of the proper low balance theory to be adopted in determining the extent to which the trust may be impressed upon the various properties, if the decision that there has been a sufficient tracing of trust funds be upheld.

6. If It Be Assumed That the Impressment of a Trust Upon the Properties Involved Was Proper, the Amount Thereof Could Not Exceed the Amount of the Lowest Balance in the Account Prior to a Given Purchase and Subsequent to the Last Deposit of Trust Moneys Therein, Such Low Balance to Be Computed by Deducting All Withdrawals From the Account During Each Day From the Opening Balance of Such Day, as Held by the Master and the Court.

It was practically conceded by cross-appellant that the extent of the trust which it sought to impress upon the various properties referred to in the Master's Report could not in any case exceed the amount of the lowest balance in the commingled fund prior to the date of any given purchase out of the commingled fund and subse-

quent to the date of the last deposit of trust moneys therein. The theory of replenishment by later deposits of the trustee's own money, to which cross-appellant apologetically referred to in its brief before the Master, has been expressly disavowed by the Supreme Court (*Schuyler v. Littlefield, supra*), and other Federal Court decisions.

Such being the case, we must first ascertain the true legal meaning of the term "lowest balance." Having done this, we must scan the evidence in the case in order to ascertain the showing which has been made in this connection.

Cross-appellant advanced three distinct theories for discussion under this head: first, that the closing balances of each day afford the true test; that if not the former, then the closing balances of each day as fortified by the few low intermediate daily balances shown by the bank records; and, lastly, if neither of the former methods be deemed to be correct, then the irreducible minimum afforded by the deduction from the opening balance of each day of all withdrawals made during the day irrespective of deposits shown. The Master, and hence the court, held this last method to be the proper one, and we submit the holding was correct.

Cross-appellant stressed the first method, namely, that of the opening and closing balances. No authority was cited by it in support of this position. It was held by the Master and the court that inasmuch as deposits and withdrawals throughout each day were shown, and inasmuch as cross-appellant failed to prove that the various deposits

preceded the various withdrawals during the day, the third method must be adopted. This reasoning was based largely upon the premise that subsequent deposits would not be allowed to replenish the sum (*Schuyler v. Littlefield, supra*; *In re Pacat Finance Co., supra*), and hence that cross-appellant must necessarily have proven the respective sequences of the deposits and withdrawals in order to make a showing, if such were the fact, that given deposits were made prior to given withdrawals. Cross-appellant failed to do this and hence there is no evidence whatever as to the matter of sequence. As far as the second theory is concerned, namely, that of the few low intermediate daily balances shown by the evidence, the evidence showed that those balances were in no sense a true indication of the status of the account, inasmuch as they were but the result of haphazard postings during the day, as to which the various bookkeepers would arbitrarily post certain items and ignore others irrespective of the order in which they actually passed through the bank. [Tr. pp. 98-101.]

The case of *In re Brown (supra)*, 193 Fed., at page 26, fully supports the holding that the burden was on the claimant to show, if he could, the continuous state of the account. There the Special Master found that the opening and closing balances, which in that case were taken morning and afternoon, were in excess of the amount of money originally entrusted by the *cestui*. The court squarely held that upon the evidence before it such a

finding was insufficient to support a tracing, but that the Master and the District Judge might have had other evidence before them as to the continuous condition of the account and for this reason held the tracing insufficient on other grounds. We quote:

“Moreover, it is not enough to show that there were morning and afternoon balances for several successive days large enough to cover the amount of money which was improperly converted. It might very well be that on any one day checks were presented which exhausted the morning balance and its accretions, in which event these moneys would have been dissipated. We are not prepared to assent to the proposition that subsequent deposits are to be taken as having been made to make good claimant’s money thus drawn and spent. Board of Commissioners v. Strawn, 157 Fed. 51, 84 C. C. A. 553, 15 L. R. A. (N. S.) 1100. Our own conclusion would be that the \$1,757.50 of the proceeds of claimant’s stock, which went into the Hanover Bank on August 13th, has not been shown to be any part of the balance which was turned over by that bank to the trustee on September 5th. Nevertheless the master and the District Judge seem to have reached the conclusion that it remained in the account on August 24th. Since both of them had the same understanding of the law as that above expressed, viz., that the first check drawn on any given day might sweep away the balance carried over, and that it would be the merest speculation to assume that subsequent deposits restored the original situation, it is possible that they had some evidence, which is not in this record, as to the continuous condition of the daily balances prior to December 24th.”

The above case would seem to be a complete answer to cross-appellant's contention regarding the opening and closing balances as being the proper test for the showing of low balances. As a matter of law, subsequent replenishments, as we have seen, are not to be taken as making good prior withdrawals. This means that the burden was clearly on cross-appellant to show that the respective deposits preceded the withdrawals, if such were the fact. If such were not the fact, the deposits could not, under the above rule, serve to replenish the withdrawals theretofore made. Hence, so far as this phase of the case is concerned, intervener clearly was entitled to no more than the "irreducible minimum" resulting from a total deduction of the withdrawals made during the day from the opening balance thereof. This it was awarded.

Cross-appellant naturally inveighs against the application of such a rule. No other alternative remains, however, in view of its failure to sustain the burden of proof cast upon it. If the burden were otherwise, the *Brown* case would have held the morning and afternoon balance controlling because of the failure of the *receiver* to prove the continuous condition of the account. The fact that difficulty may attend the making of proof such as required by the *Brown* case is no justification for the claim by cross-appellant that a finding should be made herein upon a theory which is wholly without justification from the evidence.

The reasons upon which the Master based his conclusions with regard to the proper low balance to be employed were eminently sound and we therefore set them forth as follows [Tr. pp. 150-156]:

"It is my opinion that the balance which is properly to be used in applying the intervenor's theory

here is the third of those above described; that is, that which is shown by deducting all withdrawals posted during the day from the opening balance, without crediting deposits for the day.

The second above described, which results from periodical postings during the day of deposits and withdrawals, after crediting the opening balance, is not properly usable, for the reason that under the bank's practice, as above detailed, such balance disregards the actual order of deposits and withdrawals in point of time, and consequently does not reflect the true state of the account at any time.

The first above described, the so-called closing balance, is not usable, for the reason that by its nature it necessarily disregards the actual order of deposits and withdrawals in point of time, and consequently does not reflect the true state of the account at any time since the previous closing balance. To take it as an accurate reflection, it must be assumed that at the moment of each withdrawal, deposits had been received in an amount sufficient to leave a balance at least equal to that resulting from the whole day's transactions. Unless such an assumption is imperative, there is an equal likelihood that at any moment of the day the deposits previously received and the withdrawals then made may have produced a balance less than that resulting from the whole day's transactions, down to zero. Admittedly, the intervenor is not entitled to the benefit of a replenishment of the account after its reduction or exhaustion; yet the closing balance would necessarily yield that benefit, if during the day the account had been reduced or exhausted. Under the burden of proof which is on the intervenor, it cannot avail itself of the assumption which is implicit in the closing balance, in default of that direct evidence which might

have been provided by the striking of time-regarding balances during the day. The failure of the bank to strike balances of that conclusive character might, perhaps, in another situation, afford some reason for looking to the closing balances, as the best evidence of which the case admits, in view of banking custom; but in the present situation the intervenor, in tracing a trust fund into and out of a common account, is bound to better proof than that indicated, and finds it at hand in the facts which support the third description of balance. The other two being inadmissible, the intervenor must content itself with the third, else it must be without any proof at all.

‘It is indispensable . . . that clear proof be made that the trust property or its proceeds went into a specific fund or into a specific identified piece of property.’ (*Empire State Surety Co. v. Carroll County*, 194 Fed. 593, 604, C. C. A. 8.) ‘No doubt the individual whose property has been converted has a high equity and is entitled to certain well-settled presumptions; but we cannot assent to the proposition that he may trace his money into any specific fund or security merely by inferences based on presumptions without substantive testimony to sustain them. The burden of proof is on the claimant at the outset; it rests upon him at the close of the case.’ (*In re Brown*, 193 Fed. 24, 29, C. C. A. 2.) ‘The burden of proof was upon the claimant to establish its ownership of the fund.’ (*First Nat. Bank v. Littlefield*, 226 U. S. 110, 57 L. ed. 145, affirming *In re Brown*.) ‘They were practically asserting title to \$9,600.00, said to have been traced into stock in the possession of the trustee. Like all other persons similarly situated, they were under the burden of proving their title. If they were unable to carry the burden of identifying the fund as representing the proceeds of

their Interborough stock, their claim must fail. If their evidence left the matter of identification in doubt, the doubt must be resolved in favor of the trustee, who represents all of the creditors of Brown & Company, some of whom appear to have suffered in the same way. Like them, the appellants must be remitted to the general fund.' (*Schuyler v. Littlefield*, 232 U. S. 707, 58 L. ed. 807, affirming *In re Brown*.)

This burden relates to the actual, not the presumptive, balance. The actual order of withdrawals and deposits in point of time is therefore material. If the postings faithfully observe that order, actual balances will result. But they do not observe it in the present case, and it is necessary therefore to seek the fact elsewhere. It is not correct to say that the relation of debtor and creditor arises between the bank and its depositor only when the items are posted. When a depositor hands in a dollar bill, and the teller takes it, the bank immediately owes him one dollar. The indebtedness is not postponed to, nor conditional upon, the bookkeeper's act in noting it on a ledger. If the bookkeeper should never enter it at all, the depositor could nevertheless sue and recover it. The same applied to checks, conversely. If the bank should pay a check for fifty cents, it would be entitled to offset it in the depositor's suit for one dollar, whether the bookkeeper had ever noted it on the ledger or not. The question in both cases is one of fact, not of bookkeeping. Thus, in *In re Brown*, 193 Fed. 24, 28, the court, after referring to the bank's books, said: 'The officers of the bank, however, testified that the order in which the entries of debit and credit were made in the books was not necessarily the order in which the separate transactions actually took place. Much testimony was

taken in the effort to establish the real sequence of events.' And the court proceeded to find the real, as distinguished from the recorded, sequence of events. We are equally concerned here with the real sequence.

It is true that in *In re Brown*, the court said: 'We are clearly of the opinion that when the question is as to the disposition of a fund in a bank account, the time when certification is signed and noted by the bank is the significant time; it is then that the credit items which make up the balance of account are segregated by the bank as against the obligation assumed by certification. So long as such certification is outstanding, the bank would not allow any of the money thus appropriated to be drawn out.' But this really fortifies the position above taken, because it evidently means that the bank, in certifying a check, looks to the actual state of the account at the time, and that it adheres to this afterwards when new checks come in. This accords with the actual practice of the bank in the present case, for the evidence here is that the bank, in certifying checks and in paying checks over the counter, looks, not alone to the entries on the books, but to the unposted deposits and checks as well. The position of the court in *In re Brown* on the necessity for regarding the actual order of deposits and withdrawals is plainly declared by the following language:

'Moreover, it is not enough to show that there were morning and afternoon balances for several successive days large enough to cover the amount of

money which was improperly converted. It might very well be that on any one day checks were presented which exhausted the morning balance and its accretions, in which event these moneys would have been dissipated. We are not prepared to assent to the proposition that subsequent deposits are to be taken as having been made to make good claimant's money thus drawn and spent. Board of Commissioners v. Strawn, 157 Fed. 51. . . . Both of them' (the Master and the District Judge) 'had the same understanding of the law as that above expressed, viz., that the first check drawn on any given day might sweep away the balance carried over, and that it would be the merest speculation to assume that subsequent deposits restored the original situation.'

This disposes of any conception of the closing balance as usable for the intervenor's purpose. It disposes of any contention that the order of time may be disregarded in an inquiry of this sort. It affirms, what appears to be conceded here, that subsequent deposits do not restore a trust fund once reduced or exhausted; on which, among many authorities, may be mentioned Schuyler v. Littlefield, 232 U. S. 707, 58 L. ed. 806, and the cases there cited.

The result of the foregoing is that the claim must fail, unless there is a minimum situation upon which the intervenor may rely: that is, a situation which assumes an order of deposits and withdrawals which at the worst must have occurred. Such a situation presents itself in a case where no deposits are made during the day in question, until all withdrawals of

that day have been effected. In that case, the order of withdrawals is indifferent, as they all precede the deposits. Now, it is a fact that withdrawals and deposits occurred each day, and that there was always an opening balance: whence some sort of balance, on one side or the other, continually resulted. This balance cannot be disregarded altogether, if there is a way of regarding it without detriment to defendants' position, correctly maintained as above stated. This position, that the time order must be observed, is preserved, and the proven existence of balances of some sort is recognized, by treating the deposits of the day as coming in after the withdrawals. As said by intervenor's brief, it 'establishes a minimum balance for each day below which it was impossible for the balance to have gone.' "

Conclusion.

We respectfully urge that the District Court erred in holding and deciding that upon the evidence and the Master's Report a sufficient tracing was established so as to warrant the imposition of a trust in any amount upon the properties referred to in the exceptions of this appellant. For this reason, we submit, the order overruling such exceptions and approving and confirming the report should be reversed.

As to the cross-appeal of Universal, we respectfully urge that, assuming a sufficient tracing, the low balance theory adopted and declared by the Special Master and

by the District Court was in all respects correct, and hence the order overruling the exceptions of cross-appellant should be affirmed.

Respectfully submitted,

HARRY J. BAUER,
ALEXANDER MACDONALD,
HENRY R. SCHULTHEIS,
FRED E. PETTIT, JR.,
A. S. HALSTEAD, JR.,

Solicitors for Appellants and Cross-Appellee George Armsby, F. S. Baer, Harry J. Bauer, Stanton Griffis, Robert E. Hunter and Albert E. Van Court, constituting the Richfield Bond Holders' Committee.

H. W. O'MELVENY,
WALTER K. TULLER,
LOUIS W. MYERS,
HARRY L. DUNN,
CLINTON LATOURRETTE,
and
PIERCE WORKS,

Solicitors for Appellant and Cross-Appellee Security-First National Bank of Los Angeles, as Trustee.

9

In the United States
Circuit Court of Appeals
For the Ninth Circuit.

The Republic Supply Company of
California, a corporation,

Complainant,

vs.

Richfield Oil Company of California, a
corporation,

Defendant.

Security-First National Bank of Los
Angeles, as Trustee, et al.,

Appellants and Cross-Appellees,

vs.

Universal Consolidated Oil Company,
a California corporation,

*Intervenor, Appellee and Cross-
Appellant,*

The Chase National Bank of The City
of New York, et al.,

Appellees.

**BRIEF OF APPELLEE UNIVERSAL CONSOLI-
DATED OIL COMPANY.**

A. L. WEIL,

LE ROY M. EDWARDS,

1016 L. A. Gas & Elect. Bldg., Los Angeles,

*Attorneys for Appellee, Universal Con-
solidated Oil Company.*

MARTIN J. WEIL,

Of Counsel.



TOPICAL INDEX.

	PAGE
Preliminary Statement	4
Argument	6
I.	
Where trust funds are commingled with those of a defaulting trustee, and moneys are withdrawn from this fund with which property is purchased, and the balance of the funds are thereafter dissipated, then the <i>cestui que trust</i> is entitled to a lien upon the property so purchased.....	6
(a) The principle of the case of <i>In re Oatway</i> not only has been applied by our federal courts, but every reason and every authority requires that it be applied in the instant case.....	12
(b) No case decided by the Supreme Court has ever disapproved of the principles announced in <i>In re Oatway</i> ..	26
II.	
When the <i>cestui</i> has clearly traced its trust money into a fund in the hands of the defaulting trustee, has identified certain specific properties purchased by the trustee from that commingled fund; has proved a dissipation of the balance, then the burden of going forward with the evidence and proving that it was not the money of the <i>cestui</i> which purchased the property rests on the trustee.....	31
III.	
The right of Universal to trace its money is limited by the lowest balance reached by the Richfield bank account between the date of misappropriation and the date of the purchase of the property.....	37
(a) The proper minimum balance that should have been used by the special master and the District Court was either the closing daily balance or the lowest posted balance	38
Conclusion	39

TABLE OF AUTHORITIES CITED.

CASES.	PAGE
American Surety Co. v. Jackson, 24 Fed. (2d) 768.....	35
Banks v. Rice, 8 Colo. 217; 45 Pac. 515.....	21
Board of Commissioners v. Strawn, 157 Fed. 49.....	31
Brennan v. Tillinghast, 201 Fed. 609.....	8, 15, 16, 31, 39
Brown, In re, 193 Fed. 30.....	29, 30, 39
Byrom v. Gunn, 102 Ga. 565; 31 S. E. 560.....	12
Camden Land Co. v. Lewis, 101 Me. 78; 63 Atl. 523.....	11
Central National Bank v. Connecticut Mutual Life Insurance Co., 104 U. S. 54, 26 L. Ed. 693.....	33, 34
City of Lincoln v. Morrison, 64 Neb. 822, 90 N. W. 905.....	22
City of Miami v. First Nat'l Bank, 58 Fed. (2d) 561.....	9
City of Spokane v. First National Bank, 68 Fed. 982.....	10
Cohens v. Virginia, 6 Wheaton, 265, 5 L. Ed. 257.....	26
Ellerbe v. Studebaker Corp., 21 Fed. (2d) 993.....	9
Empire State Surety Co. v. Carroll County, 194 Fed. 593.....	30
Equitable Trust Co. v. Conn. Brass & Mfg. Corp., 10 Fed. (2d) 913	11
Erie R. Co. v. Dial, 140 Fed. 689.....	11
Fiman v. State of South Dakota, 29 Fed. (2d) 776.....	20
First National Bank v. Fidelity, 48 Fed. (2d) 585.....	37
Frelinghuysen v. Nugent, 36 Fed. 229.....	8
Frith v. Cartland, 2 H. & M. 417; 71 Eng. Rep. 525.....	11
Gibson Co. v. Elze, 293 Pac. 958.....	12
Glidden v. Gutelius, 119 So. 140, 120 So. 1.....	12
Holmes v. Gilman, 138 N. Y. 369; 34 N. E. 205.....	11
Israel v. Woodruff, 299 Fed. 454.....	34
J. M. Acheson Co., In re, 170 Fed. 427.....	10, 34

Kineon v. Bonsall, 185 N. Y. S. 694, 134 N. E. 598.....	11, 35
Knatchbull v. Hallett, 13 Ch. Div. 696.....	9, 11
Mass. Bonding Insurance Co. v. Josselyn, 224 Mich. 159; 194 N. W. 548.....	11
Mitchell v. Dunn, 211 Cal. 129.....	20, 21
Moore v. Jones, 63 Cal. 12.....	11
Morin v. Kirkland, 226 Mass. 345; 115 N. E. 414.....	11
Myers v. Baylor University, 6 S. W. (2d) 393.....	12, 34
Oatway, In re, L. R. (1903), 2 Ch. 356.....	12, 13, 14, 15, 41
Pacat Finance Corp., In re, 27 Fed. (2d) 810.....	17
Peters v. Bain, 133 U. S. 670, 33 L. Ed. 696.....	26, 27, 32
Primeau v. Granfield, 184 Fed. 480.....	19
Schuyler v. Littlefield, 232 U. S. 707, 58 L. Ed. 806.....	
.....	26, 28, 30, 32, 37
Smith v. Combs, 49 N. J. Eq. 420, 24 Atl. 9.....	11
Smith v. Mottley, 150 Fed. 266.....	34
Smith v. Township of Au Gres, 150 Fed. 258.....	11
Southern Cotton Oil Co. v. Elliotte, 218 Fed. 567.....	11
Spencer v. Pettit, 17 S. W. (2d) 1102.....	12, 35
Taylor v. Morris, 163 Cal. 717.....	11

TEXT BOOKS AND ENCYCLOPEDIAS.

82 American Law Review, 160.....	23, 38
Professor A. W. Scott, "Money Wrongfully Mingled With Other Money", 25 Harvard Law Review, 125.....	37

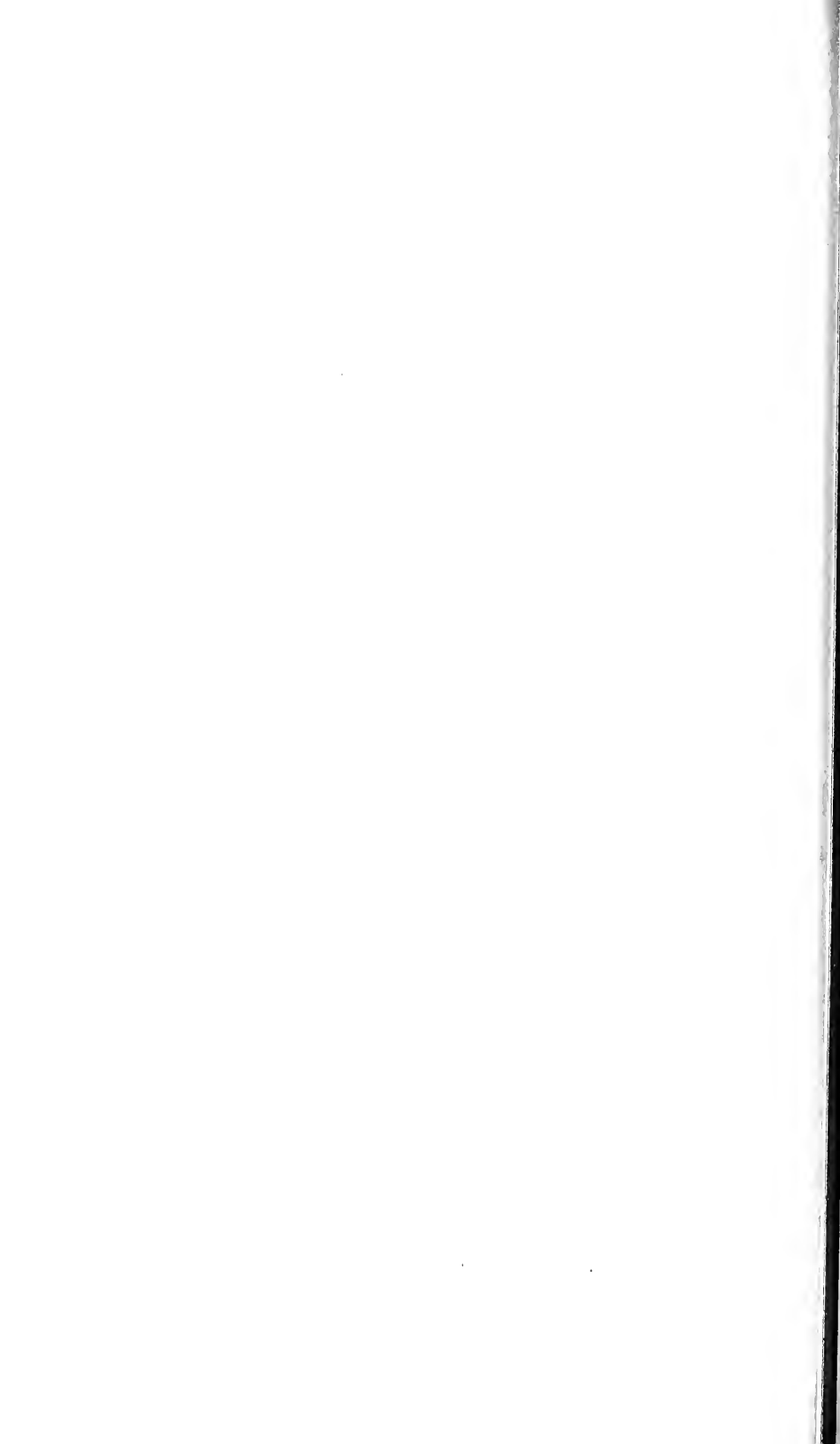

No. 7812.

In the United States
Circuit Court of Appeals

For the Ninth Circuit.

The Republic Supply Company of
California, a corporation,

Complainant,

vs.

Richfield Oil Company of California, a
corporation,

Defendant.

Security-First National Bank of Los
Angeles, as Trustee, et al.,

Appellants and Cross-Appellees,

vs.

Universal Consolidated Oil Company,
a California corporation,

*Intervenor, Appellee and Cross-
Appellant,*

The Chase National Bank of The City
of New York, et al.,

Appellees.

BRIEF OF APPELLEE UNIVERSAL CONSOLI-
DATED OIL COMPANY.

PRELIMINARY STATEMENT.

Because of the fact that Universal Consolidated Oil Company* heretofore filed its brief herein as a cross-appellant we will, as far as possible, avoid a repetition of any matters discussed in that brief. We respectfully refer this court to the preliminary statement and statement of the case contained in our brief as cross-appellant for a more complete picture of the facts involved and the events that led up to the present matter.

The brief of cross-appellant presupposed that all matters—save and except the question of the proper method of determining the lowest balance in the Security Bank—were correctly decided in favor of cross-appellant by the Special Master and the District Court. The present brief of appellee will be devoted only to answering such of the matters voiced by the appellants that refer to the propriety of the action of the Special Master and the District Court in awarding appellee the relief heretofore given—but not as to the amount of such relief.

It is to be noted that appellants' brief occupies a role not ordinarily taken by such a document—namely, that brief is attempting to answer certain briefs filed by Universal before the Master and District Court at the time of the hearings. We feel, however, that appellants have not in their brief added anything more to the arguments presented before the lower tribunals, and that appellants' claim should likewise be held untenable by this court.

* For the purposes of convenience, and following the same procedure in our brief as cross-appellant, occasionally in this brief, William C. McDuffie is referred to as Receiver; Richfield Oil Company of California is referred to as Richfield; Universal Consolidated Oil Company is referred to as Universal, and Security-First National Bank of Los Angeles is referred to as Security Bank. (All italics are ours unless otherwise noted.)

In answering the brief of appellants, we propose to follow substantially the order outlined in their brief, but we will present the argument according to the following outline:

1. Where trust funds are commingled with those of a defaulting trustee, and moneys are withdrawn from this fund with which property is purchased, and the balance of the funds are thereafter dissipated, then the *cestui que trust* is entitled to a lien upon the property so purchased.

(a) The principle of the case of *In re Oatway* not only has been applied by our Federal Courts, but every reason and every authority requires that it be applied in the instant case.

(b) No case decided by the Supreme Court has ever disapproved of the principles announced in *In re Oatway*.

2. When the *cestui* has clearly traced its trust money into a fund in the hands of the defaulting trustee, has identified certain specific properties purchased by the trustee from that commingled fund; and has proved a dissipation of the balance, then the burden of going forward with the evidence and proving that it was not the money of the *cestui* which purchased the property rests on the trustee.

3. The right of Universal to trace its money is limited by the lowest balance reached by the Richfield bank account between the date of misappropriation and the date of the purchase of the property.

(a) The proper minimum balance that should have been used by the Special Master and the District Court was either the closing daily balance or the lowest posted balance. This point is fully developed in our brief as cross-appellant.

ARGUMENT.

I.

Where Trust Funds Are Commingled With Those of a Defaulting Trustee, and Moneys Are Withdrawn From This Fund With Which Property Is Purchased, and the Balance of the Funds Are Thereafter Dissipated, Then the Cestui Que Trust Is Entitled to a Lien Upon the Property So Purchased.

Appellants concede that the law upon tracing of commingled trust funds into the hands of a wrong-doing trustee has undergone great changes from its original interpretation. As business transactions became more and more involved, the difficulty of tracing such funds quite naturally increased, so equity courts, in an effort to do substantial justice, have wisely relaxed the burdens imposed upon the injured *cestui* to assist him in his efforts to trace his funds. In doing so, these courts have adopted certain presumptions to aid him in the identification of the funds.

While they recognize that the law has undergone great changes from the days in which the *cestui* was required to identify the identical dollars abstracted from him, appellants wish the court to stop the progress of that law and to revert to those rigorous rules adopted in the Eighteenth and early Nineteenth Centuries.

Though the rules set forth by the courts in that early time were sufficient, in view of the nature of business transactions of that period, to do substantial justice, they will not suffice today because of the increased complexity of those transactions. The nature of present day business, and the amount of credit utilized by our present day

corporations in their every day business operations would, under those early rules, prevent almost every injured *cestui* from receiving the judgment to which he is entitled under the only conditions in which he needs it, namely, when the trustee is insolvent.

If the early law still applied, all that the trustee would have to do to defeat the recovery of the defrauded *cestui* would be to place the money in an account containing his own money as well and make purchases of property from that commingled fund. The defrauded *cestui* would thereupon be forced to share equally with the general creditors.

Fortunately, for defrauded *cestuis que trustent*, this *rigorous* rule of definite earmarking has been considerably relaxed by modern courts of equity. Any attempt to do substantial justice required such a relaxation. Money has no earmarks. Each dollar is the same as any other; so it would be beyond human power to say whether a particular dollar used to buy a piece of property was one of the *cestui's* dollars or one belonging to the trustee.

Appellants also admit that if Universal were merely attempting to trace its trust funds into the bank account containing the commingled moneys of Richfield and Universal, and thus attempting to reclaim same, Universal would *not* be required to identify the *identical* dollars in the account as belonging to it. (p. 50, appellants' brief.) This result would likewise be conceded notwithstanding the fact that in the meanwhile Richfield deposited in its bank account the eighty-odd million dollars, and notwithstanding the numerous withdrawals therefrom.

The result thus conceded by appellants, were the question merely one of money in the bank, would have been

arrived at without Universal having to do more than to produce testimony that its money had been misappropriated, that this money had gone into the commingled bank account, and that a certain balance came into the hands of the Receiver without any intervening exhaustion.

Appellants apparently then contend that because property was purchased with money from the commingled account, appellee must fail in its claim simply because it could not identify the *particular* dollars that went out of the commingled fund and into the property. If it is not necessary to identify the particular dollars that remained in the bank account that came into the Receiver's hands, no reason suggests itself why it should be necessary to identify the particular dollars that went into the property purchased from the commingled account. There can be no distinction in these two cases—the equities are identical in both, and similar proof should effect like results.

When Universal's money was misappropriated and deposited in the Richfield bank account, it is our claim, and it is supported by authorities, that the lien of Universal extended to the entire amount in the bank account—subject only to the minimum balance. The commingling of the money in Richfield's account did not in any wise extinguish the rights of appellee to claim the money as a trust fund, and so long as the trust money remained in the commingled fund, the effect thereof was to give appellee a prior lien upon the *entire* fund.

See:

Brennan v. Tillinghast, 201 Fed. 609 (C. C. A. 6th);

Frelinghuysen v. Nugent, 36 Fed. 229 (C. C. D. N. J.);

Ellerbe v. Studebaker Corp., 21 F. (2) 993 (C. C. A. 4th);

City of Miami v. First Nat'l Bank, 58 F. (2) 561 (C. C. A. 5th).

This doctrine has been consistently followed by our Federal Courts since the opinion of Sir George Jessel in the leading case of *Knatchbull v. Hallett*, 13 Ch. Div. 696 (1879) where it was stated:

"If a man mixes trust funds with his own, the whole will be treated as the trust property except so far as he may be able to distinguish what is his own. . . . If a man has £1000 of his own in a box on one side and £1000 of trust property in the same box on the other side, and then takes out £500 and applies it to his own purposes, the court will not allow him to say that that money was taken from the trust fund. The trust must have its £1000 so long as a sufficient sum remains in the box. So, here, Edwards could not be allowed to say that the £284 deposited in the Bank of England was his own, and that the trust portion of the fund was that which he took abroad with him." (13 Ch. Div. 719.)

Thus having a lien on the money in the commingled fund, it requires no magic for a court of equity to permit that lien to follow into property purchased with the money in the fund. The property so purchased is merely the money existing in a substituted form. As appropriately stated by the Master in his report:

"No change in the state or form of the trust property can divest it of its trust character; a court of equity will follow it through all the transmutations it may undergo in the hands of the trustee, and it

may be pursued and recovered by the beneficial owner as long as it can be traced or identified, either in its original state or in some altered or substituted form. And this applies as well after the insolvency of the trustee as before. *First Nat. Bank v. Armstrong*, 36 Fed. 59, 61, 62, C. C. S. D. Ohio; *St. Augustine Paint Co. v. McNair*, 59 Fed. (2d) 755, 757, D. C. S. D. Fla.; *Kemp v. Elmer Co.*, 56 Fed. (2d) 657, D. C. S. D. Cal.; *In re J. M. Acheson Co.*, 170 Fed. 427, 429, C. C. A. 9; *Board v. Strawn*, 157 Fed. 49, C. C. A. 6; *Peters v. Bain*, 133 U. S. 670, 33 L. Ed. 696, 699." [Tr. p. 175.]

We do not contend that the facts in the cases cited on pages 48 to 54 of appellants' brief are *entirely* identical with the facts in the instant case. However, we submit that they show conclusively that the identity of a trust fund is not destroyed by its conversion from money to property; and they are also authority to show that a defrauded *cestui* need not, in order to establish a lien upon property so purchased, prove that such property was bought with the *very* dollars taken from him by the trustee.

Thus, in the case of *In re J. M. Acheson Co.*, 170 Fed. 427, 429 (C. C. A. 9th) this court, in a decision by Judge Hunt, approved the doctrine that the *cestui* could recover property that had been purchased with commingled funds, and cited with approval, *City of Spokane v. First National Bank*, 68 Fed. 982 (C. C. A. 9th) in which it was held that:

"Where a trustee had wrongfully mixed and commingled with his own funds moneys known to be trust funds, and thereafter wrongfully invested such funds in securities which remained in his hands, the

owner of such funds was entitled to follow the same *in the form in which they had been converted* and could impress a trust for his benefit." (170 F. 429.)

The mere fact that these cases involved rulings on the pleadings does not detract in the slightest from the principle of law therein enunciated.

In addition to the cases cited in the Master's Report, *supra*, and to the same effect, are a number of cases in the State Reports, as well as other Federal cases.

See the following cases:

Equitable Trust Co. v. Conn. Brass & Mfg. Corp.,
10 Fed. (2d) 913 (C. C. A. 2.);

Southern Cotton Oil Co. v. Elliotte, 218 Fed. 567
(C. C. A. 6);

Smith v. Township of Au Gres, 150 Fed. 258 (C.
C. A. 6);

Erie R. Co. v. Dial, 140 Fed. 689 (C. C. A. 6);

Frith v. Cartland, 2 H. & M. 417; 71 Eng. Rep.
525 (1865);

Taylor v. Morris, 163 Cal. 717;

Moore v. Jones, 63 Cal. 12;

Holmes v. Gilman, 138 N. Y. 369; 34 N. E. 205;

Kincon v. Bonsall, 185 N. Y. S. 694; Aff. 134 N.
E. 598;

Smith v. Combs, 49 N. J. Eq. 420, 24 Atl. 9;

Mass. Bonding Insurance Co. v. Josselyn, 224 Mich.
159; 194 N. W. 548;

Morin v. Kirkland, 226 Mass. 345; 115 N. E. 414;

Camden Land Co. v. Lewis, 101 Me. 78; 63 Atl.
523;

Gibson Co. v. Elze, 293 Pac. 958 (Colo.);
Spencer v. Pettit, 17 S. W. (2d) 1102 (Tex.);
Myers v. Baylor University, 6 S. W. (2d) 393
(Tex.);
Glidden v. Gutelius, 119 So. 140, 120 So. 1 (Fla.);
Byrom v. Gunn, 102 Ga. 565; 31 S. E. 560.

(a) The Principle of the Case of *In re Oatway* Not Only Has Been Applied by Our Federal Courts, but Every Reason and Every Authority Requires That It Be Applied in the Instant Case.

Appellants admit that the English courts have recognized an additional relaxation to the original rule requiring the tracing of identical dollars out of a commingled trust fund, and admit that the decision of Sir Matthew Joyce in the case of *In re Oatway*, L. R. (1903) 2 Ch. 356, would have been decisive in favor of Universal, had this controversy arisen in England.

In that opinion, the learned judge established what we respectfully submit is a clear statement of the rights of an injured *cestui que trust* who was in exactly the identical position that Universal maintains in the case at bar.

The facts in *In re Oatway* disclose that a decedent was a trustee of an estate. He had advanced 3000 pounds of the funds of the estate to a third party on security. The decedent thereafter sold the security for 7000 pounds, and placed this amount in his personal bank account. Later the decedent bought other stock for 2100 pounds and paid for it with the funds in his personal account. Subsequently the bank account was entirely dissipated.

Under these circumstances, the English court in language free from ambiguity, awarded the *cestui* the right to go after the stock purchased by the decedent, and pointed out that the defaulting trustee could not claim that the investment represented only his money. Joyce, J., said in this connection:

“It is, in my opinion, equally clear that *when any of the money drawn out has been invested, and the investment remains in the name or under the control of the trustee, the rest of the balance having been afterwards dissipated by him, he cannot maintain that the investment which remains represents his own money alone, and that what has been spent and can no longer be traced and recovered was the money belonging to the trust.* In other words, when the private money of the trustee and that which he held in a fiduciary capacity have been mixed into the same banking account, from which various payments have from time to time been made, then, in order to determine to whom any remaining balance on any investment that may have been paid for out of the account ought to be deemed to belong, the trustee must be debited with all the sums that have been withdrawn and applied to his own use so as to be no longer recoverable, and the trust money in like manner be debited with any sums taken out and duly invested in the names of the proper trustees. The order of priority in which the various withdrawals and investments may have been respectively made is wholly immaterial.” (L. R. (1903) 2 Ch. 360.)

At the time the stock was purchased by the defaulting trustee, there was a greater amount in the bank account than the amount of the trust funds for which the trus-

tee was accountable. An attempt was made to prevail upon the court to permit the trustee to retain the stock purchased on the specious argument that the trustee would have been entitled to withdraw the excess moneys in the bank account over the trust funds, and with that excess the trustee could have purchased the shares involved. By this means the trustee would, of course, nullify the right of the *cestui* to follow the stock purchased. In denying the trustee this right, and in favoring the *cestui*, Joyce, J., stated:

“It was objected that the investment in the Oceana shares was made at a time when Oatway’s own share of the balance to the credit of the account would have exceeded 2137 pounds, the price of the shares; that he was therefore entitled to withdraw that sum and might rightly apply it for his own purpose; and that consequently the shares should be held to belong to his estate. To this I answer that he *never* was entitled to withdraw the 2137 pounds from the account, or, at all events, that he *could not be entitled to take that sum from the account and hold it with the investment made therewith free from the charge in favor of the trust*, unless or until the trust money paid into the account had been first restored, and the trust fund reinstated by due investment of the money in the joint names of the proper trustees, which was never done.” (L. R. (1903) 2 Ch. 360.)

That case so closely approximates the facts in the instant case that it is no surprise that appellants ask that its doctrine be not enforced. They erroneously assert that these justifiable principles promulgated by the English court in the *Oatway* case have never been adopted by the Federal Courts of this country.

Bearing in mind the overwhelming approval that has been given by our courts to the principle announced in the case of *Knatchbull v. Hallett*, *supra*, and considering that the *In re Oatway* case, *supra*, is but a development of the former case, it is understandable why our Federal Courts and State Courts have already accepted the law as announced in *In re Oatway*, *supra*.

Thus the case of *Brennan v. Tillinghast*, 201 Fed. 609 (C. C. A. 6th) *unequivocally* adopts the principles of *In re Oatway*. The *Brennan* case discloses that plaintiff therein had borrowed money from the Ironwood Bank, and deposited with that bank certain stock as collateral. In violation of its agreement, the Ironwood bank sold this stock for \$3558.00, which it then deposited to its credit in an open account in the Duluth bank. Thereafter, and from time to time, the Ironwood bank deposited additional sums in the Duluth bank and drew a number of drafts against the credit so established. However, at all times during the period in question, the open account of the Ironwood bank in the Duluth bank, after including all deposits made and deducting all drafts drawn, showed a balance in excess of the \$3558.00 at the end of each day. During the period in which the balance exceeded the amount of the trust fund, the Ironwood bank drew drafts against its open account in the Duluth bank, aggregating \$2807.00, and deposited the proceeds thereof in its cash account in its own bank. At the time it drew those drafts, its credit in the Duluth bank was greater than the amount of the trust, but before insolvency that credit was overdrawn.

The court held that plaintiff could trace \$2807.00 from the Duluth bank to the Ironwood bank, and granted plain-

tiff a preferential claim for that sum. Judge Sanford, after referring to the generally accepted rule of the *Hallett* case, states:

“ . . . This rule of presumption has no application where the evidence shows that the first moneys drawn out of the mingled fund by the *tortfeasor* were not in fact dissipated by him at all, *but were merely transferred, in a substituted form, to another fund retained in his own possession.*” (201 Fed. 614.)

Such substituted form need not be limited to cash, but, manifestly, property purchased with trust funds would likewise be in a substituted form. The application of the *Brennan* case would be just as pertinent had the fiduciary bank therein purchased stocks or bonds with the proceeds of the drafts.

Judge Sanford continued and pointed out that in such a case the trust attaches to the substituted form in which the property is retained by the fiduciary,

“ . . . and that the right to follow the trust in such form is *not lost* by reason of the fact that the *tortfeasor* thereafter draws out and spends for his own purposes the balance of the fund in which the trust money was originally mingled. *The English case of In re Oatway, L. R. 2 Ch. 356, 359, directly sustains this view.*” (201 Fed. 614.)

The last sentence, which has been italicized by us, was left off the quotation submitted by appellants in their brief on page 61.

Appellants endeavored to distinguish the facts and circumstances of *Brennan v. Tillinghast* from those in the

instant case in an effort to show that our federal equity law was not expanded to the degree to which *In re Oatway* had expanded the law of England. They claim that the reference therein to the *Oatway* case may be disregarded because such reference was not absolutely necessary to the decision. Nevertheless the court actually made the citation; actually considered that the case of *In re Oatway* was a correct statement of the federal equity law as applied to a situation such as the one presented in the case at bar; and actually relied upon the *English case*.

The same unavailing effort was made by appellants to overcome the effect of the case of *In re Pacat Finance Corp.*, 27 Fed. 2nd 810 (C. C. A. 2nd). That case is likewise an out and out approval of the doctrine of *In re Oatway*.

The facts disclose that Pacat was in the business of buying and selling foreign exchange, and subsequently was adjudged a bankrupt. One Berardini had paid Pacat money in New York on numerous occasions with directions to pay an equivalent sum in lire to Berardini's business place in Naples. 750,000 lire remained unpaid by Pacat under this arrangement at the date of the bankruptcy.

When Berardini paid Pacat for the 750,000 lire, which were never delivered, Pacat deposited the checks therefor in its general account. Berardini did not claim any interest in the balance in that account, but showed that Pacat had sent checks for 3,000,000 lire that were deposited to Pacat's credit with Credito Italiano right after Berardini's payments, of which amount 92,000 lire was on hand at the time of the bankruptcy.

Berardini first sought to establish an express trust in the specific lire remaining in Pacat's possession, but this attempt was unsuccessful. The court, however, did decide that a constructive trust had been established and as a result thereof gave Berardini the 92,000 lire which were held by Pacat at Naples, being the balance of the 3,000,000 lire.

The court, in deciding that the balance of those lire in Credito Italiano were held by virtue of a constructive trust, said:

“While Berardini's dollars cannot *be literally traced* into any of these lire credits, *the applicable principle is that stated by Joyce, J., In re Oatway*, L. R. (1893) 2 Ch. 356, 359: ‘. . . It is, in my opinion, equally clear that when any of the money drawn out has been invested, and the investment remains in the name or under the control of the trustee, the rest of the balance having been afterwards dissipated by him, he cannot maintain that the investment which remains represents his own money alone, and that what has been spent and can no longer be traced and recovered was the money belonging to the trust.’”
(27 F. (2d) 813.)

Though counsel in their brief contend that this case is distinguishable for the reason that the money of the *cestui* always remained money, the fact is that the money of the *cestui* was used to buy lire credits. Obviously lire credits are *not* money in the United States, and such a purchase required as complete a transformation of the original trust fund as existed in the instant case. We submit that the purchase of lire credits stands on no different basis than the purchase of more Universal stock or other property in the instant case.

As stated by Judge Learned Hand in a very able opinion in the case of *Primeau v. Granfield*, 184 Fed. 480, 484, a case later reversed by the Circuit Court of Appeals because the claimant did not come into equity with clean hands:

“The language about presumed intent in *Knatchbull v. Hallett*, *supra*, which Sir George Jessel laid down with his customary vigor, was merely a way of giving an explanation by a fiction of the right of the beneficiary to elect to regard his right as a lien. That it is a fiction appears clearly enough in this case where Granfield could have had no intention about the investments as he meant to use all the money for himself anyway. To say that in such a case he will be ‘presumed’ to intend to take his own money out first is merely a disingenuous way common enough, to avoid laying down a rule upon the matter. This fiction in *Re Oatway* (1903) 2 Ch. Div. 356, would have brought the usual injustice which fictions do bring, when pressed logically to their conclusion. Logically, the trustee’s widow, in that case, was quite right in claiming the first withdrawal, although the trustee had invested it profitably, and had subsequently wasted all of the fund which had remained in the bank. That was, of course, too much for the sense of justice of the court which awarded to the wronged beneficiary the investment, intimating that the rule in *Knatchbull v. Hallett*, *supra*, applied only where the withdrawals were actually spent and disappeared. If to that rule be added the qualification that if the first withdrawals be invested in losing ventures, then the beneficiary is to have a lien, if he likes, till he uses up that whole investment, and then

may elect to fall back for the balance upon the original mixed account from which the withdrawal was made, there is no objection, but it is a very clumsy way of saying that he may elect to accept the investment if he likes, or to reject it. The last is the only rule which will preserve to the beneficiary the option which he has when the investment is made wholly with his money." (184 Fed. 484.)

See, also:

Fiman v. State of South Dakota, 29 Fed. (2d) 776, 781. (C. C. A. 8th.)

The appellate courts of several states have adopted the foregoing doctrines. While we have no quarrel with the assertion of counsel that the federal courts are not bound by the decisions of the Supreme Courts of the several states, still we feel that those state decisions, when based upon a consideration of the general principles of law and equity, are entitled to consideration, particularly when one of those decisions is a decision of the state in which the transaction occurred.

In the case of *Mitchell v. Dunn*, 211 Cal. 129, defendant was appointed guardian of the estate of her brother, an incompetent. As such guardian she maintained two bank accounts, a personal one and a guardianship one; but no attempt was made by the guardian to keep the accounts separate. The guardian had purchased some real estate which she had taken in her own name but she had paid for same with a check on the guardianship account. Shortly after the purchase, the account rendered to the court by the guardian was approved and it showed therein an amount in excess of the amount of the purchase price

of the property. However, prior to the termination of the guardianship, the guardian had dissipated the entire remainder of the guardianship funds.

The court, in holding that the real property so purchased was trust property, said:

“At any rate, the presumption in reference to withdrawals, in a contest between the *cestui* and trustee, based as it is, on a theory of right doing, cannot be indulged in to defeat the *cestui's* right of recovery when all the evidence shows a consistent course of conduct amounting to wrong doing. To permit the presumption to be used for that purpose would be to permit its use as a shield for wrongdoing, and that we are not inclined to do. . . . (211 Cal. 135.)

“In the case at bar the plaintiff has sufficiently traced the trust funds. The specific piece of property involved was purchased with money taken from a fund containing trust moneys. All other moneys were dissipated. *The law will not permit the trustee to say that the only permanent investment made with moneys from the fund was with personal funds and that the dissipated funds belonged to the cestui.* Under such circumstances it must be held that the property was purchased with trust funds and that defendant holds the title in trust for plaintiff.” (211 Cal. 136.)

Banks v. Rice, 8 Colo. 217; 45 Pac. 515, 517, was a case very similar in its facts to the instant case.

There plaintiff made a contract to supply defendant with Colorado Supreme Court Reports. Defendant was to sell the books and take out a 5% commission and remit the balance. Defendant failed to remit \$434.00 which he converted to his own use, and mingled with his own

funds. With these commingled funds he paid the current expenses of his business and also purchased new goods and materials. There was a constant turnover of these goods, but a large stock of merchandise passed to the trustee on defendant's bankruptcy.

The court held that even though the stock was changed several times, the trust fund remained in the business and could be traced into the stock of goods which the trustee in bankruptcy held. They allowed a lien on those remaining goods because regardless of the changes the fund underwent as there was still a charge upon the property purchased with the commingled funds. The court said:

“It will be presumed that, in drawing upon the consolidated fund for that purpose, it drew upon its own money, and used its own money, and that all the money of the petitioners was applied in the purchase of goods and is represented in the company's assets. In other words, the presumption, in the absence of evidence, is that the petitioners' money was applied where it can be reached and not where it cannot be reached.” (45 Pac. 517.)

In *City of Lincoln v. Morrison*, 64 Neb. 822, 90 N. W. 905, 909, Pound, C. (in rendering the opinion in that case), declared a trust upon certain warrants bought with a commingled fund consisting of trust money and money of the trustee, and said:

“It will be remembered that after the city's money came into the bank it bought the warrants, using \$1750 of the moneys in which the funds of the city had been mixed, and \$35,000 borrowed on security of the warrants. The receiver contends that since

there was over \$40,000 in cash in the bank at the time, of which but \$6000 belonged to the city, it will be presumed that the \$1750 was the bank's own money. Such would be the case, without doubt, had the bank withdrawn the money and dissipated it in some fashion. But it did not do this. . . . In accordance with the presumption that whatever was retained and not dissipated was the city's money, and not the bank's, these warrants and their proceeds in the hands of the receiver represent money to which the city has a prior claim, in which the general creditors have no right to share. The city's right to follow the money does not fail because no one can say what part of the cash on hand in the bank went into the warrants. The city had a charge upon the whole in any form in which the bank might keep it. When all was wasted except the warrants, that charge remained upon them, because they were a part of that fund, though in an altered form."

(90 N. W. 909.)

The matter is ably summed up by the author of the note in 82 *A. L. R.* at page 160, where it is stated:

"The presumption in question, being based upon a fiction invented solely for the protection of the *cestui que trust*, should not be applied in such manner as to defeat his right. The application of the presumption would have that effect in a case where the bank withdrew and preserved, by investment or in another fund, a part of the fund with which the trust fund had been commingled, and subsequently dissipated the residue of the commingled fund; and the *better view*, as pointed out by Professor Scott in

27 Harvard L. Rev. 125, 132, is that the part of the common fund left after the first withdrawal, and later dissipated by the bank, will not be presumed to be or represent the trust fund. In other words, in such a case, the part first drawn out will not be presumed to have belonged to the trustee."

To the same effect, but in different language, the Master reported:

"It is contended that the estoppel above alluded to (that the first funds withdrawn are those of the trustee) applies to disbursements for all objects alike, the purchase of land as well as the purchase of an ice-cream soda. Applying this theory to the present case, Richfield must be held to have invested its own money in the property in question, and to have dissipated the trust money afterwards; because the conversion of trust money into other property would be a violation of its duty, and such a breach must not be imputed to it. Thus Richfield makes a clear gain, and the estoppel which was intended to protect the victim defeats him. If this development is necessary, equity may still refuse to follow it; but in my opinion it proceeds from a fallacy, and is not necessary. On the contrary, it is a *misapplication* of the doctrine, and is *indeed inconsistent therewith*; for the doctrine concerns the dissipation, not the retention, of the fund, and it is *immaterial* whether it be retained in one form or another.

"When the trust money is segregated and so traced into property, it is admitted by all the cases (*Peters v. Bain*, 33 L. ed. 696, for example), that the property is but a substituted form, and takes the place of the money. If the owned money were similarly segregated and traced into property, the same would

of course be true; the property would be but a substituted form of the owned money. If there is no segregation, but the mixed fund is traced into property, the same still remains true; the property is but a substituted form of the mixed fund. If there was any trust money in the mixed fund, it remains in the substituted mixed form; and it remains there in the same order in which it lay in the mixed fund itself: *first for the benefit of the cestui, and first to be retained for him*, and only afterwards for the benefit of the holder, and only afterwards to be retained for him. *The cestui's money has not been dissipated at all; on the contrary, it has been retained for him, but in another form.* The holder of the mixed fund might invest the whole thereof in bonds at the same time; if the contention were sound, that would defeat the cestui's title as effectually as would a dissipation of the whole fund at one turn of the roulette wheel; but it is obvious that no such result would follow: the cestui's money would still be in the bonds, to the same extent that it was in the fund. In the case of a partially invested mixed fund, the estoppel does not come into play at all, any more than it does in the case of a wholly invested or wholly undissipated fund. It is accordingly *repugnant* to the rule itself, and certainly not a necessary consequence thereof, to reward the guilty and penalize the innocent in the manner proposed.

“Moreover, if there were such a thing as an estoppel which concludes the opposite party instead of the one nominally estopped, it should be frankly abandoned by a court of equity.” [Tr. pp. 178, 179.]

(b) No Case Decided by the Supreme Court Has Ever Disapproved of the Principles Announced in *In re Oatway*.

It is the contention of appellants, in effect, that the two cases of *Peters v. Bain*, 133 U. S. 670, 33 L. Ed. 696, and *Schuyler v. Littlefield*, 232 U. S. 707, 58 L. Ed. 806, practically dispose of the entire case adversely to the claims of Universal.

In considering these cases, it is important to bear in mind the language of Chief Justice Marshall in *Cohens v. Virginia*, 6 Wheaton 265, 5 L. Ed. 257, 290:

“It is a maxim not to be disregarded, that general expressions, in every opinion, are to be taken in connection with the case in which those expressions are used. If they go beyond the case, they may be respected, but ought not to control the judgment in a subsequent suit when the very point is presented for decision.”

(5 L. Ed. 290.)

As a matter of fact, both of the cases cited by appellants *support* the general position claimed by appellee, and an examination of their facts will readily show that they do not tend to defeat the recovery of Universal.

The case of *Peters v. Bain*, *supra*, admittedly permits a lien to be applied on property purchased with trust funds, and in that case where the money was segregated, the tracing into the property was complete. As there pointed out, the property *was but a substitute in form and took the place of the money*.

As to the second transaction in the *Peters* case, the court properly disallowed the attempt to trace the trust funds under the extremely complicated facts of that case. These funds, as pointed out, "*may or may not* have been made up in part of what had been wrongfully taken from the bank."

In addition to the facts quoted by appellants, the following facts are pertinent in the *Peters* case: The books of Bain & Bro. were entirely unreliable; no general ledger was kept; and transactions involving large amounts were kept only on memorandum slips and were explainable only with the aid of one of the Bains. "Everything, so far as Bain & Bro. were concerned, was found in the greatest confusion."

In commenting on the above situation in the *Peters* case, the Master in his report, stated:

"There was thus before the court nothing but the bare fact that money had been received and money had been invested. It was impossible to ascertain any of the facts regarding the account *which are shown in the present case*. . . . When and in what items the moneys were received from the bank, when and in what items other moneys were received and commingled with the former, whether the mingled account was at any time exhausted, what, if any balance, remained therein at any time, what, if any, was the lowest balance at any time, when and in what amounts and in what properties investments were made from the mingled fund, whether a low balance was exhausted at any time by an investment, what, if any, part of the trust money remained after an investment for application on a subsequent investment,—*none of these things was shown, nor could*

they be shown; and it was necessary to show them, on any theory of the case. *They have been shown in the present case with precision.* The question of applying the principle here relied on did not present itself in the Bain case. It was not mentioned; and for the reason that the case lacked the facts upon which alone the question could arise. *The point now under discussion was accordingly not involved, and could not be involved.* There is, in my opinion, nothing in *Peters v. Bain* which prevents the application of the rule of *In re Oatway* and *Brennan v. Tillinghast.*" [Tr. pp. 186, 187.]

The case of *Schuyler v. Littlefield*, *supra*, is the principal authority for the rule that trust funds deposited in the trustee's bank account and thereafter dissipated cannot be treated as reappearing in the sums subsequently deposited after the depletion of the original deposit. Thus the Supreme Court states:

"The case involves an application of the rule that where one has deposited trust funds in his individual bank account, and the mingled fund is at any time wholly depleted, the trust fund is thereby dissipated, and cannot be treated as reappearing in sums subsequently deposited to the credit of the same account." (58 L. Ed. p. 807.)

In tracing the misappropriated funds in the present case, we have at all times adhered strictly to this doctrine by the recognition of the low balances, and have made no effort to charge any of the funds which subsequently appeared in the bank from other sources and replenished the deposit.

The difficulty of the court in the *Schuyler* case was in determining the time of the certification of a certain check which wholly depleted the account in the bank. Unless it could be proved that the check was certified before the deposit of the *cestui's* fund, the fund was entirely dissipated. The *cestui* failed in his proof as is more fully shown by the opinion of the Circuit Court in the same case, 193 Fed. 30.

The cited case has an additional complication in that the controversy was almost entirely between persons standing in the same position. That is, most of the adversary parties were those for whom the brokers were trustees. The court expressly refused to decide whether all the *cestuis* could have, by joining together, followed their total funds into the asset purchased, but held that between one *cestui* and another, the burden of proof was not sustained.

As a last resort in the cited case, the plaintiff therein endeavored to establish a claim against collateral that was released by the payment of certain loans for which the collateral had been given as security. There was no effort to show that any of the commingled funds were used in purchasing this collateral.

As pointed out in *In re Brown*, 193 Fed. 30,

“Whether it (the \$266,000 check) had actually been deposited before the loans were paid is not shown. If it were not deposited until afterwards, it certainly was not used to pay them off.” (193 Fed. 33.)

Thus, the *cestui* in the *Brown* case wholly failed to show that at the time the loans secured by the collateral were paid off, his money was in the bank account.

On the contrary, we have in the instant case been very meticulous in showing that Universal's money was in the bank account at the time when each of the assets claimed was purchased.

In every instance where we have sought to follow a particular asset, the total fund was not dissipated, but there was at least that much money of the commingled funds remaining in the bank. At no time when any asset which we are seeking to follow, was purchased, had the balance in the account prior to the purchase, fallen below the amount expended for that particular asset.

It thus appears that the two cases, on which appellants chiefly rely, support the legal position for which we contend, but the judgment in those cases were against the *cestui* for failure of proof. No such failure exists in the case at bar.

Appellants in further support of their contention, that the dollars used to buy property must be identified as being the identical coins which were put into the commingled account, cite the case of *Empire State Surety Co. v. Carroll County*, 194 Fed. 593. In that case, as in *Schuyler v. Littlefield*, and *In re Brown*, the controversy was not *solely* between the *cestui* and the insolvent creditor; but one depositor was attempting to obtain a preference over all the depositors who had been likewise defrauded into depositing their money in ignorance of the bank's insolvency. The court prefaced that portion of the opinion in which it denied the preference with a statement that showed clearly the distinction, saying:

“A *cestui que* trust who is the equitable owner of his fund for one sound reason is as much entitled to it as another who is the equitable owner of his

fund for many sound reasons, and the latter is entitled to *no preference* over the former in payment out of a common fund in which the trustee has commingled them." (194 Fed. 603.)

Appellants also cite in support of their position the case of *Board of Commissioners v. Strawn*, 157 Fed. 49, C. C. A. 6. We respectfully submit, however, that the opinion in that case was superseded by *Brennan v. Tillinghast*, 201 Fed. 609, also decided by the Circuit Court of Appeals of the Sixth Circuit.

II.

When the Cestui Has Clearly Traced Its Trust Money Into a Fund in the Hands of the Defaulting Trustee, Has Identified Certain Specific Properties Purchased by the Trustee From That Commingled Fund; Has Proved a Dissipation of the Balance, Then the Burden of Going Forward With the Evidence and Proving That It Was Not the Money of the Cestui Which Purchased the Property Rests on the Trustee.

Counsel for the appellants have deputed a considerable portion of their brief to an argument that a mere showing that trust funds have gone to swell the assets of an insolvent is insufficient to establish a preferential lien, and though there are Federal cases that support this doctrine, we have at no time claimed that we were entitled to a recovery upon that basis. We admit that under the generally accepted principles of law a *cestui*,

in order to establish his right to a preferential lien, must trace his trust funds into property in the hands of the insolvent, but we further respectfully submit that under the law as it exists, we have succeeded in so doing.

We also concede that the burden of proof is on Universal to prove that its money had been misappropriated by Richfield, and that in fact a trust relationship existed rather than that of debtor and creditor. This phase of the matter has been *entirely removed* from the case, however, by the stipulation of appellants that Richfield misappropriated from Universal a net sum of \$1,625,000, and that such misappropriation was such as to constitute Richfield *the trustee of a constructive trust in which Universal was the beneficiary*. [Tr. p. 97.]

The burden was also upon Universal to prove, where the trustee has not kept the trust funds separately, into what fund his money had gone. But the facts in the instant case are not in any dispute. The moneys appropriated by Richfield from Universal went *directly* into the Richfield bank account. From this account certain *identified properties* were purchased, and the amounts paid for these properties are not in dispute. [Tr. p. 102 *et seq.*] The doubts that existed in *Peters v. Bain* and *Schuyler v. Littlefield, supra*, are not present in the instant case.

The bank account was dissipated a few days before receivership, and consequently Universal, under the es-

tablished authorities, was precluded from going beyond that date in its attempt to trace its funds. [Tr. p. 98.]

As heretofore noted, and as conceded by appellants, the appellee would have had no difficulty in recovering its money if the amount involved had remained in the bank account of Richfield at the time of the receivership. No reason suggests itself why additional burdens should be imposed upon Universal merely because Richfield substituted for the trust money in the commingled fund certain specified items of property.

With the foregoing facts stipulated or proved, the appellee has made out a *prima facie* case, and is in a position to rest. At this juncture appellee was entitled to a lien on the property purchased with the money of appellee that went into the property.

The duty of going forward with the evidence from this point was on Richfield, and it was up to Richfield to prove, if it could, that it was its own funds that purchased the particular properties rather than those of Universal. There is an utter dearth of testimony on this point, for Richfield failed to offer any evidence on this matter whatsoever.

As stated in a headnote by the court in the case of *Central National Bank v. Connecticut Mutual Life Insurance Co.*, 104 U. S. 54, 26 Law. Ed. 693:

“That, so long as trust property can be traced and followed into other property into which it has been converted, the latter remains subject to the trust, and

that if a man mixes trust funds with his own, the whole will be treated as the trust property, *except so far as he may be able to distinguish what is his own*, are established doctrines of equity and apply in every case of a trust relation, and to moneys deposited in a bank account, and the debt thereby created, as well as to every other description of property.” (26 L. Ed. 694.)

The Supreme Court of Texas reached the same result in *Meyers v. Baylor University*, 6 S. W. (2d) 393 (Court of Civil Appeals of Texas), where it is stated:

“It is quite true that the burden of proof was upon plaintiff to establish the trust, but when proof of the fiduciary relationship of the parties was made, the betrayal of the trust, and probable amount of the embezzlements shown, a *prima facie* case was presented, and the burden was then on Meyers to show, if he could, that his money, and not that of the plaintiff, paid for the properties in whole or in part. Meyers was in possession of the exact facts, and it was his duty to reveal the entire truth. As he did not testify, and made no explanation of this matter, every intendment is against him.” (6 S. W. (2d) 394, 395.)

See, also:

Israel v. Woodruff, 299 Fed. 454 (C. C. A. 2);

In re J. M. Acheson Co., 170 Fed. 427 (C. C. A. 9);

Smith v. Mottley, 150 Fed. 266 (C. C. A. 6);

Kineon v. Bonsall, 185 N. Y. S. 694. Aff. 134 N. E. 598;

Spencer v. Pettit, 17 S. W. (2d) 1102 (Tex.).

This does not mean that the burden of proof does not rest with the *cestui* throughout the case. If the trustee produces *any* evidence to show that it was his money that went into the property, the *cestui* must then show, by a preponderance of the evidence, that trust funds were used in the purchases. This distinction was clearly pointed out by Judge Rudkin in the case of *American Surety Co. v. Jackson*, 24 Fed. (2d) 768 (C. C. A. 9), where he says:

“It will thus be seen that the rule itself rests largely on a legal fiction. But, if there is a presumption that trust funds have not been wrongfully misapplied or criminally used by the officers of the bank, as held by this court in the Spokane County case, *supra*, and such a presumption no doubt obtains, it would seem to follow as a necessary corollary that the *burden was on the bank* or its successor in interest *to prove* that the trust funds or some part of them were in fact wrongfully misappropriated or criminally used by the bank. This presumption in nowise conflicts with the rule that in the end the claimant must trace the funds and establish his claim thereto by clear and satisfactory proof as against the receiver who represents all creditors.” (24 Fed. (2d) 770.)

Appellants in urging that the burden of proof rested upon the *cestui* through the whole case, overlook the very obvious qualification of the rule pointed out in the case just cited by us.

In commenting upon this latter case, and others cited by us, they point out that the case involved merely the tracing of funds into a commingled fund. We submit that there is no equitable principle that requires the rule to be changed when the trust funds are being traced into property bought with, and substituted for, that commingled fund. The same rule of equitable estoppel that precludes the trustee from claiming the balance in the bank account as his own, applies with equal force and vigor to estop the defaulting trustee in claiming that the property purchased from the commingled fund is his property alone. To do otherwise is to penalize an innocent party with a resulting gain to the wrongdoer.

If appellants contend that Universal is required to earmark each dollar that came from the commingled fund, and to prove that the *identical* coin which Richfield took from it was used in the purchase of the specific property, we reply that the law throws no such *aeqis* around the rascality of faithless trustees.

III.

The Right of Universal to Trace Its Money Is Limited by the Lowest Balance Reached by the Richfield Bank Account Between the Date of Misappropriation and the Date of the Purchase of the Property.

Although certain authorities approve the doctrine that subsequent deposits will be considered as replenishments of the trust fund, we have at no time sought to establish this doctrine, which we believe to be opposed to the weight of authority.

At all times during the trial of this action, Universal has recognized that the law limited its right to claim its funds from the account of Richfield in the Security Bank to the lowest balance reached by that account subsequent to the misappropriations.

In re Hallett, supra;

Schuyler v. Littlefield, supra;

First National Bank v. Fidelity, 48 Fed. (2d) 585.

Appellants contend that the presumption established by the *Hallett* case, namely, that the first moneys withdrawn are those of the trustee, prevents the recovery of Universal. However, as has been heretofore demonstrated, that rule applies only when the funds withdrawn are dissipated by the trustee. When he uses the moneys withdrawn to make investment in property which he retains, those investments are *substituted for the commingled fund and may be claimed by the cestui*.

As pointed out by Professor A. W. Scott in his article, "*Money Wrongfully Mingled With Other Money*," 25 Harvard Law Review 125, 132:

“It so happened that in the earlier cases the part first withdrawn from the commingled fund was invariably dissipated, and the claimant wished to establish an interest in the remainder, which interest he was allowed, as has been stated, on the ground that it is presumed that the wrongdoer withdraws his own money first. But when the part first withdrawn is invested or otherwise preserved, and the remainder is dissipated, *the application of that presumption would throw a loss on the claimant.*”

In the note in 82 *A. L. R.*, at page 160, the author states:

“The fiction in question was invented for the benefit of the *cestui que trust* in cases where his trust money is commingled with the funds of the trustee, and it should not be followed to its logical conclusion where to do so would *defeat* recovery in a case no less meritorious than those in which it is employed in the aid of a recovery. *There should be consistency in results rather than merely in the steps employed in reaching a result.*”

(a) The Proper Minimum Balance That Should Have Been Used by the Special Master and the District Court Was Either the Closing Daily Balance or the Lowest Posted Balance.

Appellants in their brief, page 65 *et seq.*, would have this court adopt the conclusions of the Special Master on the amount of the minimum balances, in the event that it was proper to impress a trust on the property purchased by Richfield; thus disregarding the lowest daily closing balances and posted balances.

To avoid the use of the lowest daily closing balances, counsel rely entirely on the case of *In re Brown*, 193 Fed. 24 (C. C. A. 2nd). We do not at this point discuss this case, as it is discussed in our brief as cross-appellant. We do, however, wish to emphasize here that the daily closing balances were used in the case of *Brennan v. Tillinghast*, 201 Fed. 609 (C. C. A. 6th).

In order to avoid the use by the Special Master of the lowest posted balances, we are somewhat surprised to find that appellants attribute to the Security Bank the statement that their posted balances were “. . . but the result of haphazard postings during the day.” This effort of the Security Bank to avail itself of the possible difficulties imposed on Universal in connection with the posted balances seems to us, to say the least, to come in rather bad taste from that source.

We do not propose to duplicate the matters set forth in our brief as cross-appellant on the question of the proper minimum balance that should have been adopted by the Master. On these points we merely state our position in this matter, namely, that the Master should have used the lowest daily closing balances as the proper balances, or at the very minimum the lowest posted balances.

Conclusion.

Applying all the statements of general principles to the specific facts in the respective cases to which the principles refer, it will be seen that in the end they amount to the same thing. Whether the court presumes, in bank cases, that the first money taken out and dissipated is the trustee's own funds; whether the court throws the duty on the trustee of going forward with proof that his own

funds were used in the acquisition of assets; or whether the court presumes that invested money is the *cestui's* and the dissipated funds are those of the trustee, they all in their reasoning revert to one basic principle.

That principle is that when trust funds and personal funds of the trustee are once shown to have been inextricably commingled in a common bank account, the *cestui* has a lien on the whole of the commingled fund, and on every asset that can be shown to have been purchased with the commingled funds.

A great deal of the disparity of statement of principle arises from the attempts of the courts to conceive of the existence of two separate funds, but the result arrived at in all of them, regardless of the principle stated, is that there is but one fund on which, and on the property purchased therewith, the *cestui* holds a lien. This lien follows all the property purchased, regardless of the amount invested, subject to the limitation, of course, that when the *cestui* is made whole the lien ends.

The trustee cannot be heard to say that all of the money that went into the purchase of these assets was his own, and that all funds which he had belonging to the *cestui* were dissipated by him. Furthermore, the trustee, under well-recognized principles, should be compelled to do equity. As the Master aptly stated in his report:

“Another rule, equally appealing to the conscience, should have effect: the rule which requires the fiduciary, in such a case, *to do equity*. Nothing could be more abhorrent to the conscience than that the fiduci-

ary should set aside to himself the gain and to his beneficiary the loss. *The difficulty is created by himself; the burden of it should be on him. To do equity, he must concede the first fruits to the beneficiary. Before he can be heard at all, he must be required to do so.*" [Tr. p. 179.]

The facts in this case are without any confusion—the salient ones being either stipulated or being conclusively shown by undisputed evidence. The doctrine of the case of *In re Oatway* fully supports our position, and this doctrine has been adopted and approved by every well considered case that has had an analogous situation.

There can be no doubt but that in decreeing a lien in favor of Universal for its misappropriated funds, the Special Master acted correctly; but we feel that the only error committed by the Special Master was in the theory adopted of what was the proper minimum balance to use. We respectfully refer this court to our brief as cross-appellant in this case where we have fully developed, and we feel demonstrated, that the Special Master should have used the lowest daily closing balance, or, as the very minimum, the lowest posted balances.

Respectfully submitted,

A. L. WEIL,

LE ROY M. EDWARDS,

Attorneys for Appellee, Universal Consolidated Oil Company.

MARTIN J. WEIL,

Of Counsel.

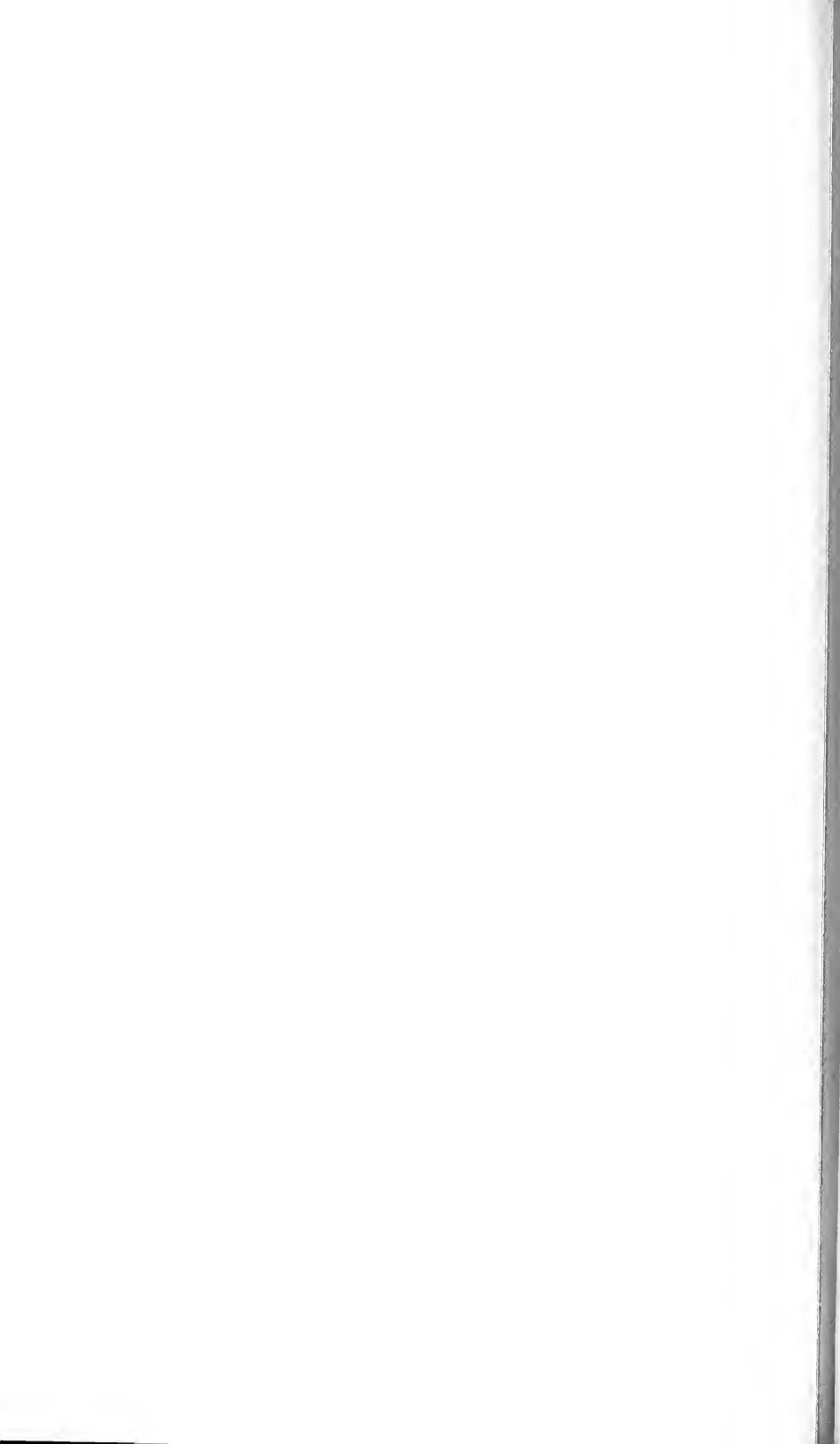

812

10

In the United States
Circuit Court of Appeals
For the Ninth Circuit.

THE REPUBLIC SUPPLY COMPANY OF CALIFORNIA, a corporation,
Complainant,

vs.

RICHFIELD OIL COMPANY OF CALIFORNIA, a corporation,
Defendant.

SECURITY-FIRST NATIONAL BANK OF LOS ANGELES, as Trustee,
GEORGE ARMSBY, F. S. BAER, HARRY J. BAUER, STANTON
GRIFFIS, ROBERT E. HUNTER and ALBERT E. VAN COURT,
known and designated as Richfield Bondholders' Committee,
Appellants and Cross-Appellants,

vs.

UNIVERSAL CONSOLIDATED OIL COMPANY, a California Cor-
poration,

Intervener, Appellee and Cross-Appellant,

THE CHASE NATIONAL BANK OF THE CITY OF NEW YORK,
BANK OF AMERICA, a corporation, PAN AMERICAN PETRO-
LEUM COMPANY, a corporation, WILLIAM C. McDUFFIE, as
Receiver for Pan American Petroleum Company, a corporation, RICH-
(Continued on Inside Cover.)

BRIEF OF DAVID R. FARIES AS AMICUS
CURIAE ON BEHALF OF UNIVERSAL
CONSOLIDATED OIL COMPANY.

DAVID R. FARIES,

Subway Terminal Bldg., 417 S. Hill St., L. A.,

*Amicus Curiae on Behalf of Universal Consolidated Oil
Company.*

DON F. TYLER,

LEONARD S. JANOFSKY,

Of Counsel.

FILED

JUN 19 1932

FIELD OIL COMPANY OF CALIFORNIA, a corporation, UNITED STATES OF AMERICA, THE REPUBLIC SUPPLY COMPANY OF CALIFORNIA, a corporation, CITIES SERVICE COMPANY, a corporation, ROBERT C. ADAMS, THOMAS B. EASTLAND, EDWARD F. HAYES and RICHARD W. MILLAR, known and designated as Pan American Bondholders' Committee, G. PARKER TOMS, ROBERT C. ADAMS, F. S. BAER, ROBERT E. HUNTER, HENRY S. McKEE and RICHARD W. MILLAR, known and designated as Richfield Pan American Reorganization Committee, WILLIAM C. McDUFFIE, as Receiver of Richfield Oil Company of California, SECURITY-FIRST NATIONAL BANK OF LOS ANGELES, a national banking association, PACIFIC AMERICAN COMPANY, a corporation, AMERICAN COMPANY, a corporation, MANUFACTURERS TRUST COMPANY OF NEW YORK, a corporation, CITIZENS NATIONAL TRUST & SAVINGS BANK OF LOS ANGELES, a national banking association, FIRST NATIONAL BANK AND TRUST COMPANY OF SEATTLE, a national banking association, CONTINENTAL ILLINOIS BANK AND TRUST COMPANY, a corporation, THE FIRST NATIONAL BANK OF CHICAGO, a national banking association, CHEMICAL NATIONAL BANK AND TRUST COMPANY, a national banking association, and CALIFORNIA BANK, a corporation, M. W. LOWERY, HENRY S. McKEE, O. C. FIELD, R. R. TEMPLETON, known and designated as Richfield Unsecured Creditors' Committee,

Appellees.

TOPICAL INDEX.

	PAGE
Introduction	4
Statement of the Case.....	6
Specification of Errors Relied Upon.....	8
Argument	9
I.	
The closing balances of the particular days in question should be used in determining the amount of the trust lien.....	9
Lowest daily closing balance method.....	10
Lowest daily posted balance method.....	17
Method adopted by special master.....	21
II.	
Where a trustee commingles trust funds with his own, invests a portion of such funds in property which he retains, and dissipates the remainder, the rule in the federal courts allows the cestui a lien upon the property retained.....	27
Conclusion	47

TABLE OF AUTHORITIES CITED.

	PAGE
Board of Commissioners v. Strawn, 157 Fed. 49.....	41
Brennan v. Tillinghast, 201 Fed. 609.....	32, 34, 36, 41, 43
Brown, In re, 193 F. 24.....	24
Central Natl. Bank v. Conn. Mnt. Life Ins., 14 U. S. 54, 26 L. ed. 693.....	43
City Bank of Dowagiac, In re, 186 Fed. 413.....	41
Empire State Surety Co. v. Carroll, 194 Fed. 593.....	41
Farmers Bank v. Bailey, 221 Ky. 55, 297 S. W. 938.....	13
Fiman v. State of South Dakota, 29 Fed. (2d) 776.....	32, 41
Grand Forks Co. v. Baird, 54 N. D. 315, 209 N. W. 782.....	12
Hawaiian Pineapple Co. v. Browne, 69 Mont. 140, 220 Pac. 1114	13
Israel v. Woodruff, 299 Fed. 454.....	14
J. M. Acheson Co., In re, 170 Fed. 427.....	15
Knatchbull v. Hallett, L. R. 13 Chancery Division, 696.....	43
Meyers v. Baylor, 6 S. W. 2d 393.....	11
Mitchell v. Dunn, 211 Cal. 129.....	44
National Bank v. Life Insurance Co., 104 U. S. 67, 26 L. Ed. 693	14
Oatway, In re, 2 Chancery Division 356.....	
.....7, 23, 27, 31, 33, 34, 36, 37, 39, 40, 41, 45, 46	
O. A. Brown & Co., In re, 189 Fed. 433.....	31, 36
Pacat Finance Corporation, In re, 27 Fed. (2d) 810.....	
.....32, 34, 36, 43	
Peters v. Bain, 133 U. S. 670, 33 L. ed. 696.....	37, 39, 40, 41
Primeau v. Granfield, 184 Fed. 480.....	27
Primeau v. Granfield, 193 Fed. 911, cert. den. 225 U. S. 708, 56 Law. Ed. 1267.....	30, 36, 43
Schumacher v. Harriet, 52 Fed. 2d 817.....	11
Schuyler v. Littlefield, 232 U. S. 707, 58 L. Ed. 806.....	24, 37, 39, 40
Walker v. Holden, 6 Fed. Sup. 262.....	11
—————	
Exodus 22-4.....	23
27 Harvard Law Review, 125, 129.....	43

In the United States
Circuit Court of Appeals
For the Ninth Circuit.

THE REPUBLIC SUPPLY COMPANY OF CALIFORNIA, a corporation,
Complainant,

vs.

RICHFIELD OIL COMPANY OF CALIFORNIA, a corporation,
Defendant.

SECURITY-FIRST NATIONAL BANK OF LOS ANGELES, as Trustee,
GEORGE ARMSBY, F. S. BAER, HARRY J. BAUER, STANTON
GRIFFIS, ROBERT E. HUNTER and ALBERT E. VAN COURT,
known and designated as Richfield Bondholders' Committee,
Appellants and Cross-Appellants,

vs.

UNIVERSAL CONSOLIDATED OIL COMPANY, a California Cor-
poration,
Intervener, Appellee and Cross-Appellant,

THE CHASE NATIONAL BANK OF THE CITY OF NEW YORK,
BANK OF AMERICA, a corporation, PAN AMERICAN PETRO-
LEUM COMPANY, a corporation, WILLIAM C. McDUFFIE, as
Receiver for Pan American Petroleum Company, a corporation, RICH-
FIELD OIL COMPANY OF CALIFORNIA, a corporation, UNITED
STATES OF AMERICA, THE REPUBLIC SUPPLY COMPANY
OF CALIFORNIA, a corporation, CITIES SERVICE COMPANY,
a corporation, ROBERT C. ADAMS, THOMAS B. EASTLAND,
EDWARD F. HAYES and RICHARD W. MILLAR, known and
designated as Pan American Bondholders' Committee, G. PARKER
TOMS, ROBERT C. ADAMS, F. S. BAER, ROBERT E. HUNTER,
HENRY S. MCKEE and RICHARD W. MILLAR, known and desig-
nated as Richfield Pan American Reorganization Committee, WILLIAM
C. McDUFFIE, as Receiver of Richfield Oil Company of California,
SECURITY-FIRST NATIONAL BANK OF LOS ANGELES, a
national banking association, PACIFIC AMERICAN COMPANY, a
corporation, AMERICAN COMPANY, a corporation, MANUFAC-
TURERS TRUST COMPANY OF NEW YORK, a corporation,
CITIZENS NATIONAL TRUST & SAVINGS BANK OF LOS
ANGELES, a national banking association, FIRST NATIONAL BANK
AND TRUST COMPANY OF SEATTLE, a national banking asso-
ciation, CONTINENTAL ILLINOIS BANK AND TRUST COM-
PANY, a corporation, THE FIRST NATIONAL BANK OF CHI-
CAGO, a national banking association, CHEMICAL NATIONAL
BANK AND TRUST COMPANY, a national banking association, and
CALIFORNIA BANK, a corporation, M. W. LOWERY, HENRY S.
MCKEE, O. C. FIELD, R. R. TEMPLETON, known and designated
as Richfield Unsecured Creditors' Committee,

Appellees.

BRIEF OF DAVID R. FARIES AS AMICUS
CURIAE ON BEHALF OF UNIVERSAL
CONSOLIDATED OIL COMPANY.

INTRODUCTION.

This brief is filed by the undersigned counsel as *amicus curiae* on behalf of Universal Consolidated Oil Company pursuant to an order of this Honorable Court, made in the above entitled matter on the 25th day of April, 1935.

We are filing this brief in the hope that some of the matters discussed herein may be of assistance to this Honorable Court in its consideration of the matters raised in these consolidated appeals. We are also particularly interested in the determination of these questions in view of the fact that we represent Mr. R. D. Miller, one of the minority stockholders of Universal Consolidated Oil Company (hereinafter referred to as Universal).

Subsequent to the confirmation of the report of the Special Master by the learned Trial Court, Mr. Miller, as a minority stockholder of Universal, after discussing the matter with his personal counsel, felt that an appeal should be taken to this Honorable Court. He, therefore, in writing, requested the Board of Directors of Universal Consolidated Oil Company to authorize such an appeal, and upon their refusal so to do, filed his petition with the learned Trial Court wherein it was prayed that he, as a stockholder, be allowed to prepare an appeal on behalf of Universal. In that petition, Mr. Miller alleged, and, at the hearing on the same, introduced evidence to the effect that five out of the nine directors of Universal were controlled by Richfield Oil Company of California (hereinafter referred to as Richfield) or its receiver. This petition was denied and Mr. Miller thereupon proceeded with

an appeal to this Honorable Court from the order denying him leave to intervene.

In the meantime, Universal and Security-First National Bank of Los Angeles (hereinafter referred to as Security Bank), proceeded to take appeals to this Honorable Court from the original order of the trial court confirming the report of the Special Master and overruling exceptions thereto. Consequently, a stipulation, or "Agreement Dismissing Appeal Pursuant to Rule (20 C. C. A. 9)" as it was called, was executed by counsel for Universal, counsel for Security Bank, as trustee, counsel for William C. McDuffy, as Receiver of Richfield, and the undersigned, as counsel for Mr. Miller. The original of that stipulation is on file herein. It contains the agreement, in brief, that the appeal of Mr. Miller should be dismissed, that he in return should be given at least ten days' notice of any motion or agreement to dismiss the appeals which are now being presented to this Honorable Court, and further, that his counsel should have leave to file a brief as *amicus curiae* on behalf of Universal Consolidated Oil Company.

Pursuant to this stipulation this Honorable Court in the October Term of 1934, on Thursday, the 25th day of April, 1935, with the Honorable Curtis D. Wilbur, Senior Circuit Judge presiding, and the Honorable William Denman, Circuit Judge, and the Honorable Clifton Mathews, Circuit Judge, also present, made the following order in this cause:

"Upon consideration of the certificate of the Clerk of the District Court herein, and stipulation of counsel for respective parties, and good cause therefor appearing, IT IS ORDERED that the appeal of R. D. Miller herein be, and hereby is dismissed, without costs to any party, that a decree of dismissal be filed and entered accordingly, and the mandate of this

court as to appeal of R. D. Miller be issued forthwith.

“And, pursuant to said stipulation, leave is hereby granted to David R. Faries to file a brief in this cause on behalf of Universal Consolidated Oil Company as *Amicus Curiae*.”

STATEMENT OF THE CASE.

In this brief we will not burden the court with any detailed statement of the case in addition to that contained in the brief of the cross-appellant Universal. In view of the concession on the part of all parties that there was a misappropriation of Universal funds by Richfield, and that such misappropriation constituted Richfield the trustee of a constructive trust of which Universal was the beneficiary, the only question left for determination by this Honorable Court concerns the sufficiency and method of the tracing of these trust funds into property purchased by Richfield. [Tr. pp. 96 and 97.]

The misappropriated funds, as is more fully set forth in Universal's statement (Universal's Brief pp. 7-11), were deposited in the bank account of Richfield. In the process of tracing these funds through this bank account, it became necessary to determine the lowest bank balance as a result of familiar rules of tracing into mixed-money funds. Three different methods of calculating the lowest bank balance were considered: (One) The method of taking the lowest daily closing balance on the bank's record. (Two) The method of taking the lowest posted balance on the books of the bank of any given date. (Three) The method of taking the opening balance of a particular day, and arbitrarily deducting therefrom all of the withdrawals made on that day, refusing to credit

any of the deposits for the day, and considering that remainder as the lowest balance. [Tr. p. 147.]

The third method was the one adopted by the Special Master, and confirmed by the learned Trial Court. It resulted in Universal being given a trust lien of \$403,993.92 and a general claim of \$779,154.31. It is the contention of Universal and of the undersigned *amicus curiae* that the adoption of this method was erroneous. We will endeavor to demonstrate that method number one, to-wit, the lowest daily closing balance on the bank's record is the only fair method of ascertaining the lowest intermediate balance. This would entitle Universal to a trust lien of \$849,864.25, and a general creditor's claim of \$333,283.98. The first part of our argument will be in support of this contention.

The Special Master, after arriving at what he considered to be the correct lowest intermediate balance, proceeded to hold that sum had been traced into certain specific properties purchased by Richfield with funds withdrawn from its bank account, although the remainder of the bank account was thereafter dissipated. The appellant Security Bank as trustee, in its appeal contends that this tracing of trust moneys from the bank account into certain properties purchased and retained by Richfield was not supported by the evidence. In support of that contention counsel for Security Bank argue that the doctrine of the English case of *In re Oatway*, 2 Chancery Division 356, has been repudiated in the Federal Courts.

It is our contention that the doctrine of *In re Oatway* does apply to this particular case, and in this respect the reasoning of the Special Master and its confirmation by the learned Trial Court should be confirmed. The latter portion of our argument will be addressed to this point.

SPECIFICATION OF ERRORS RELIED UPON.

In this brief, as *amicus curiae* on behalf of Universal, we will rely upon the same specification of errors set forth in Universal's brief on page 15 thereof. They are as follows:

1. The District Court erred in approving and confirming the finding of fact and/or conclusion of law of the Special Master that said intervenor was entitled only to a trust imposed upon certain designated parcels, to-wit: Parcels 1 to 8, inclusive, in the total sum of \$403,993.92. [Assignment of Errors, 2, 4; Tr. pp. 266, 267.]

2. The District Court erred in approving and confirming the finding of fact and/or conclusion of law of said Special Master limiting the recovery of Universal to the low bank balance theory adopted by said Special Master. [Assignment of Errors, 6, 9, 11; Tr. pp. 268, 269.]

3. The District Court erred in failing to decree and enforce in favor of Universal a trust on Parcels 1 to 9, inclusive, in the aggregate amount of \$849,864.25. [Assignment of Errors, 5, 12, 13; Tr. pp. 268, 270, 271.]

4. The District Court erred in failing to allow intervener a trust based upon the closing bank balance at the end of each day in the bank account of Richfield. [Assignment of Errors, 7, 8, 10; Tr. p. 269.]

ARGUMENT.

I.

The Closing Balances of the Particular Days in Question Should Be Used in Determining the Amount of the Trust Lien.

It will be admitted that the burden of proof is upon the beneficiary of a constructive trust to trace his misappropriated funds into specific property before he can claim that property as his own, or before he can assert a lien thereon. In this case, Universal admittedly occupies the position of the beneficiary attempting to establish a preferred claim, and we do not question the fact that Universal must sustain this burden of proof. We likewise concede for the purposes of this case, that when misappropriated moneys are deposited in a fluctuating fund, which likewise contains moneys of a trustee, the trust lien of the beneficiary is limited to the lowest intermediate balance in that fund prior to the date of any identified purchase out of that fund.

We respectfully submit, therefore, that the question presented to us here is what constitutes sufficient evidence to establish a *prima facie* case as to the lowest intermediate bank balance in the bank account of Richfield. We believe that the daily closing balances do establish such a *prima facie* case.

We do not contend that that showing relieves Universal of the burden of proof, but we respectfully maintain that unless Richfield, as the constructive trustee, can by competent evidence show affirmatively that some other figure represents the lowest intermediate balance, the burden of proof has been satisfied. With this principle in mind, let us examine the evidence introduced before the Special Master upon this point.

Lowest Daily Closing Balance Method.

First, it was shown by Universal that the misappropriated moneys were deposited in Richfield's bank account in Security Bank, and there commingled with moneys of Richfield. It was also shown that the properties and assets upon which a trust lien is claimed were paid for in whole or in part with checks from that bank account. [Tr. p. 97.]

It appeared that this account had been dissipated a week before the appointment of the Receiver for Richfield. Universal therefore proceeded to show the lowest daily closing balances between the taking of Universal funds and withdrawals from the bank account which were converted into assets claimed by Universal. These daily closing balances reflected all checks charged against the bank account and all deposits credited to it during the day. [Tr. p. 98.] These balances are set forth in Schedule "A", column No. 3, transcript p. 102 through p. 105.

We believe that a thorough discussion and examination of the evidence will show that these daily closing balances constitute the only competent evidence on this point. These daily closing balances are accepted in ordinary business practice as the proper method of determining the balances in a bank account. In fact, the Security Bank, apparently considered the daily bank balance as the only true balance, because, although by their system of book-keeping they recorded certain trial posted balances throughout the day, those posted balances were never given to the depositor when he requested the amount of his balance. [Tr. p. 99.] It is not only the custom but it is reasonable that business practice should adopt the closing balance as the only true balance because it is the balance

at the end of the day, when *all* withdrawals have been charged against the account and *all* deposits have been credited to that account. It not only seems self-evident that that balance should be used, but a Court of Equity is entitled to rely upon modern business practices in matters of this kind.

Schumacher v. Harriet (C. C. A. 4th, 1931), 52 Fed. 2d 817, 820, 821, contains a good statement of this rule:

“The duty of courts is to apply the principles of law and equity to the conditions of our changing life; and we have no doubt that in view of modern banking practices the modern but well settled doctrine of tracing trust funds is applicable to the situation here disclosed.”

The case of *Walker v. Holden*, 6 Fed. Sup. 262, 265, a 1934 decision of the District Court of Illinois is to the same effect.

At any rate, the evidence of Universal that its misappropriated funds had been deposited in Richfield's bank account and that the books of Security Bank disclosed these certain lowest daily closing balances, prior to the invested withdrawals, without other evidence, clearly established a *prima facie* case, and therefore satisfied the burden of proof. If that is true, that state of the evidence then left the case in a position where it was incumbent upon Richfield to introduce evidence which would show that some other balance should be adopted, or concede that Universal had traced its funds to that point. This conclusion is, we believe, amply supported by the following authorities.

In *Meyers v. Baylor*, a Texas case, found in 6 S. W. 2d 393, cited at page 27 of the appellant Universal's

brief, it appeared that Meyers had embezzled the University's money and deposited it in his own bank account. He then drew upon the mixed fund and purchased certain real property. In holding that the University was entitled to impose a trust upon that property, the court stated the rule as follows:

“It is quite true that the burden of proof was upon plaintiff to establish the trust, but when proof of the fiduciary relationship of the parties was made, the betrayal of the trust, and probable amount of the embezzlement shown, a *prima facie* case was presented, and the burden was then on Meyers to show, if he could, that his money, and not that of the plaintiff, paid for the properties in whole or in part.

“Meyers was in possession of the exact facts, and it was his duty to reveal the entire truth. As he did not testify and made no explanation of this matter, every intendment is against him.”

In the instant case, Richfield, the misappropriating trustee, and its depositary, Security Bank, were in possession of the facts, as was the embezzler Meyers in the cited case. Universal proved the fiduciary relationship, the betrayal of the trust, the amount of the embezzlement, and showed from the books of the bank the closing balances for the days in question. It had clearly sustained its burden of proof, and to paraphrase the Texas court, if Richfield or the bank did not explain the matter further, every intendment should be against them.

In addition to that case cited in Universal's brief, we would like to call the attention of this Honorable Court to the following additional authorities.

Grand Forks Co. v. Baird, 54 N. D. 315, 209 N. W. 782 (1926).

Here an action was brought by a county against the receiver of a bank to impress a trust arising out of the wrongful deposit of county funds. A judgment was entered in favor of the county to the extent of the lowest amount in the bank between the deposit and the receivership. In affirming this judgment the court said:

“The judgment is limited to the cash assets. If they were ever lower than at the time the bank was closed, such fact does not appear; but we are of the opinion that, in the absence of evidence, it should be presumed that they were never less than at the time of closing; also, that it is incumbent on the defendant to offer evidence to the contrary.” (209 N. W. at 783.)

Farmers Bank v. Bailey, 221 Ky. 55, 297 S. W. 938 (1927).

In this case the bank wrongfully sold certain bonds and mingled the proceeds therefrom with its own funds. Apparently no evidence on the question of tracing was offered other than a showing as to the amount of the closing balance.

In considering this point, the court said:

“The amount of cash on hand at periods prior to the closing of the bank is not shown. It does not appear that the cash balance was ever less than the balance on hand when the bank closed. As the proceeds of the bank were traced into the cash of the bank, and the presumption is that the bank discharged its own obligations from its own funds, we are constrained to the view that the bondholders have a preferred claim on the cash on hand when the banking commissioner took charge.”

Hawaiian Pineapple Co. v. Brozrne, 69 Mont. 140, 220 Pac. 1114 (1923).

In this case involving the tracing of the proceeds of a draft into the collecting bank which became insolvent and was placed in receivership before the avails were forwarded to the plaintiff, the court held that a trust relationship had been established and discussed the matter of tracing as follows:

“ . . . counsel for defendant says, correctly, . . . the preference may not extend above the amount of the lowest balance on hand in the collecting bank between the time of making the collection and its enforced closing. So far as we are appraised by the record, the sum of \$1801.62 was the lowest amount of cash in the bank at any time after the collection was made. *If the contrary is true, the facts were in the receiver's possession, but he did not disclose them.*” (These and all other italics are ours unless otherwise noted.)

Israel v. Woodruff, 299 Fed. 454, 457 (C. C. A. 2d) (1924).

The Circuit Court of Appeals, in considering the question now before us stated the rule as follows:

“If one mixes trust funds with his own, the same will be treated as a trust property, except so far as he may be able to distinguish what is his own.”

National Bank v. Life Insurance Co., 104 U. S. 67, 26 L. Ed. 693 (1881).

In this case, involving the tracing of trust funds into a bank account, the rule was stated in the head note written by Mr Justice Mathews, the writer of the opinion, as follows:

“That, so long as trust property can be traced and followed into other property into which it has been

converted, the latter remains subject to the trust, and that if a man mixes trust funds with his own, the whole will be treated as the trust property, except so far as he may be able to distinguish what is his own, are established doctrines of equity and apply in every case of a trust relation, and to moneys deposited in a bank account, and the debt thereby created, as well as to every other description of property.”

In re J. M. Acheson Co., 170 Fed. 427, 429 (C. C. A. 9) (1909).

This Honorable Court then consisting of Gilbert and Ross, Circuit Court Judges, and Hunt, District Judge, speaking through Hunt, J., upon considering the sufficiency of a bill in equity to establish a trust, stated the doctrine of this Circuit as to questions of proof in the establishment of trusts in mixed money funds as follows:

“In carrying out the rule, when it comes to proof, the owner must assume the burden of ascertaining and tracing the trust funds, showing that the assets which have come into the hands of the trustee have been directly added to or benefited by an amount of money realized from the sales of the specific goods held in trust; and recovery is limited to the extent of this increase or benefit. *City Bank of Hopkinsville v. Blackmore*, 75 Fed. 771, 21 C. C. A. 514; *Cushman v. Goodwin*, 95 Me. 353, 50 Atl. 50. If, however, he succeeds in making requisite proof, *it then devolves upon the bankrupt, or the trustee who takes the property of the bankrupt in the same relation that it was held by the bankrupt, to distinguish between what is his and that of the cestui que trust.* *Smith v. Mottley*, 150 Fed. 266, 80 C. C. A. 154;

Smith v. Township of Au Gres, 150 Fed. 257, 80 C. C. A. 145, 9 L. R. A. (N. S.) 876.”

Smith v. Mottley, 150 Fed. 266, 268 (C. C. A. 6th) (1906).

This case involved the establishment of a trust upon the assets of a bank which had wrongfully received the beneficiary's money some ten days prior to a general assignment for the benefit of creditors. Apparently the proof extended no further than that, and after holding that a trust relationship existed, the Circuit Court of Appeals for the Sixth Circuit discussed the matter as follows:

“In the absence of any proof to the contrary, the reception of the funds being so near to the assignment by the bank, it may be presumed that the assets which came to the hands of the trustee were augmented by the appropriation of the proceeds of the check. *If it were not so, the burden was on the trustee to prove it; or, if not augmented to the whole amount of the check, then to what amount they had been lost out.* It is shown that three times the amount of this fund remained in the bank to the time of the assignment and came to the trustee. The burden of showing that his property has been wrongfully mingled in a mass of the property of the wrongdoer is upon the owner; but, when this is done, the burden shifts to the wrongdoer. It is for him to distinguish between his own property and that of the innocent party. *Smith, Trustee, v. Township of Au Gres, supra*; *Hart v. Ten Eyck*, 2 Johns. Ch. 108; *Starr v. Winegar*, 3 Hun. (N. Y.) 49; *Stephenson v. Little*, 10 Mich. 441, 450; *Ryder v. Hathaway*, 21 Pick. (Mass.) 298, 306; *Seavey v. Dearborn*, 19 N. H. 361; *Robinson v. Holt*, 39 N. H. 557, 75 Am.

Dec. 233; *Janes v. Burnet*, 20 N. J. Law, 635, 642; *Kreuzer v. Cooney*, 45 Md. 591; *Elgin Bank v. Schween*, 127 Ill. 580, 20 N. E. 681, 11 Am. St. Rep. 174; *Mayer v. Wilkins*, 37 Fla. 244, 19 South. 632; *Weil v. Silverstone*, 6 Bush. (Ky.) 698; *Stuart v. Phelps*, 39 Iowa 20; *Loomis v. Green*, 7 Me. 386; *Dillingham v. Smith*, 30 Me. 383; *Lehman v. Kelly*, 68 Ala. 192; *Franklin v. Gumersell*, 9 Mo. App. 90.”

It seems self-evident in the light of these cases, and the common business practice of accepting daily closing bank balances as the true balances of an account, that if the evidence with respect to the bank account had stopped at this point, Universal would have undoubtedly sustained its burden of proof. If the only evidence concerning the status of the bank account were these daily closing balances of the Security Bank, no one could seriously contend that the lowest intermediate balances were not thereby established. Certain other evidence, however, was introduced concerning the status of the account. Let us now examine it to see what affect it has upon the daily closing balances.

Lowest Daily Posted Balance Method.

On pages 99 and 100 of the transcript it is shown that evidence was introduced to the effect that Security Bank, as a result of its bookkeeping methods, obtained certain posted balances throughout the day. These posted balances resulted from the fact that customers' accounts were kept on bookkeeping machines. The customers' ledger sheets were inserted in those machines for the purpose of posting checks or deposits, and before the sheet could be extracted from the machine it was necessary to place the balance on the ledger sheet. The evidence disclosed, how-

ever, that these posted balances which were obtained merely for purposes of convenience did not disclose the actual status of the account. This fact is, perhaps, best summarized in the words of the transcript on page 100.

“The balances that appear during the course of the day do not necessarily show all of the checks on that account that have come to the bank, or all of the deposits to that account that have been made up to the time that balance appeared, nor do they show the time of day when such balances were made, nor do they show the order in which deposits were made or the order in which checks are presented during the course of the day. It would be possible for other checks against the account to have been presented for payment and other deposits to have been made to the account prior to the time when the balance in question was taken. But those checks and deposits would not be reflected in the particular balance either because they had not been passed on to the bookkeeper for posting or because they were not included in the particular group of checks upon which the bookkeeper was working at the moment.”

A mere reading of this agreed statement of the evidence introduced at the hearing before the Master would seem to us to conclusively demonstrate that the evidence of the intermediate posted balances could not by the wildest stretch of the imagination be considered as refuting the *prima facie* case established by Universal when the daily closing balances were introduced in evidence. In this connection, we believe it will be helpful to examine the reasoning of the Special Master with respect to this evidence.

An examination of the Master's report shows that he realized that the so-called posted balances did not reflect

the true state of an account. In a part of his report appearing on page 149 of the transcript, he says in referring to the bookkeeper's practice:

“The balance he strikes does not necessarily represent the actual balance of all deposits and checks at the time. It represents only the balance of those checks and deposits which are then posted. The balance taken periodically during the day, as aforesaid, does not necessarily give a true picture of the low balance for the day, because it ignores the unposted checks.”

Again, in that portion of his report appearing on page 150 of the transcript, he says:

“The intermediate balances are merely working balances, so that the bookkeepers can go ahead with their work. *The only balance that the bank will recognize as really showing the state of the account is the one at the close of the day.*”

As a result of this reasoning, therefore, the Special Master rejected the so-called intermediate posted balances, and although he realized, as the above quotation shows, that the only balance the bank recognizes as really showing the state of the bank account is the one at the close of the day, he did not take the next logical step and adopt that closing bank balance as the true one. He proceeded instead, to discuss the rule that the burden of proof rests upon the *cestui* attempting to establish a trust lien. This then led him to the following conclusion

“This burden relates to the actual, not the presumptive, balance. The actual order of withdrawals and deposits in point of time is therefore material. *If the postings faithfully observe that order, actual balances will result.* But they do not observe it in

the present case, and it is necessary therefore to seek the fact elsewhere." [Tr. p. 153.]

The only difficulty we respectfully submit with the Master's conclusion is that there was no definite evidence in the record showing that the closing balance of the day did not represent the true status of the account. The only evidence other than the closing balances was with respect to the intermediate posted balances, and these the Master himself admitted did not disclose the true status of the account. They, therefore, did not in any way refute the *prima facie* case established by the daily closing balances. The learned Master, however, apparently reached his conclusion, not as a result of any evidence, but as a result of the merest surmise. In referring to the system of bookkeeping maintained by the Security Bank, he says:

"Under this system, it would be possible for an opening balance to show \$100,000.00 and the closing balance to show \$100,000.00, and yet in the meantime checks might have been entered on the account which would completely wipe out the balance at noon and then other deposits in the afternoon might be made which would bring it up to a closing balance of \$100,000.00. *There is no way under the system used by said bank of telling whether that actually happened on a particular day or not.*" [Tr. p. 148.]

The Master's very statement of the proposition disclosed that there was no evidence introduced to the effect that some withdrawal had reduced the account below the lowest daily closing balances. In fact, he says:

"There is no way under the system used by said bank of telling whether that actually happened on a particular day or not."

If that is true, there obviously was no evidence in the record to refute the *prima facie* case established by Universal, and the daily closing balances should have been accepted by the Special Master, and the Court in the same manner as they were accepted by the Security Bank as the only true showing of the state of a customer's account.

Method Adopted by Special Master.

After reaching the conclusion that the daily closing balances should be rejected because of the bare possibility, unsupported by any evidence, that some withdrawal might have reduced the bank account to a lower figure, the Master adopts an entirely different method of ascertaining the lowest intermediate bank balance. This method consisted of first taking the opening balance of a particular day, assuming, without any evidence to that effect, that all withdrawals were made on that day before any deposits were made, and as a result arbitrarily deducting all withdrawals from that opening balance while completely disregarding any deposits made during the day. This resulted in a complete disregard of the actual facts of the case, and a holding of Universal's trust lien to the barest minimum. The practical result was that under this method adopted by the Master, Universal was only entitled to a trust lien of \$403,993.92, instead of a trust line of \$849,864.25 disclosed by the daily closing balances.

It is true that the rule adopted by the Special Master holds the defrauded Universal to a very minimum of recovery, and protects the defaulting trustee Richfield from any possibility of an excessive trust lien. This does not, however, we respectfully suggest, in the absence of clear affirmative evidence demonstrating that this result must be reached, seem to us to be equity. Certainly Universal

and its approximately 2800 defrauded minority stockholders deserve greater consideration from a court of equity than Richfield or Security Bank, the trustee of its bond indenture. The cases we have cited indicate that the defrauded *cestui* has met his burden of proof when he traces his money into a mixed fund and shows a *prima facie* low balance. That is his *prima facie* case. It is then incumbent upon the wrongdoer to show by affirmative evidence that what appears to be *prima facie* the lowest balance, is, in fact, not correct. The Master, however, relieves the wrongdoer of this responsibility, disregards the *prima facie* case of the lowest daily closing balances and holds Universal to a minimum entirely unsupported by the evidence.

In illustration of the effect of the rule adopted by the Master upon Universal, let us assume that the opening balance was \$1,000.00, immediately thereafter a deposit of \$500.00 was made, and then, just before closing, a \$200.00 check was paid. It certainly could not be contended that a low balance of \$800.00 occurred at any time that day, yet that would be exactly the conclusion reached by the Special Master under his rule.

This rule is not supported by any authority and is certainly not supported by business practice. When a bank computes the interest on a customer's balance, it uses the closing balance for the day. When the bank estimates the right of a customer to borrow against his account, the daily closing balance is always used. If a bank should follow the rule adopted by the Special Master, in answering a call of the Comptroller of the Currency for a statement, it would certainly be liable for the falsification of such a statement. Undoubtedly, if a bank followed the

Master's rule in preparing monthly statements and subtracted all withdrawals, but refused to credit deposits, a customer would strongly and properly object.

Courts of equity have always recognized the high equity of a defrauded *cestui* and his right to claim his money or property stolen by the faithless trustee. As business methods became more complex, the leading cases of *In re Hallett* and *In re Oatway*, both of which are discussed under the next point in this brief, considered the difficulties attendant upon tracing trust moneys into mixed money funds. In the present instance, the complexity of the bank accounts, and the bookkeeping methods of Security Bank should not be allowed to defeat the equitable claims of Universal.

Since the days of the Mosaic Law, courts have recognized the superior right of the victim to recover his goods, or money, from the hands of the thief.

"If the theft be certainly found in his hand, he shall restore double."—*Exodus 22-4*.

This rule is particularly applicable to this case because it has been found and commented upon by the Master that Richfield conspired to acquire the stock of Universal because of the \$1,700,000.00 quickly available to Universal's treasury. Richfield realized that this cash would permit it to pay for a controlling interest in Universal, out of Universal's own funds, and this is precisely the program Richfield followed. The burden of this stupendous theft fell heavily upon the minority stockholders of

Universal, and justice and equity can only be done to them by restoring this misappropriated money or its product. The fact that Security Bank does not strike correct balances on its bank accounts until the end of each day, should not in these modern times prevent a court of equity from restoring to Universal's minority stockholders that which was stolen. Certainly, the fact that the stolen funds were deposited by the wrongdoer in such a bank account, should not prevent Universal and its minority stockholders from relying upon the daily closing balances of that bank in the absence of clear affirmative proof refuting that showing.

The Security Bank relies heavily upon the cases of *In re Brown*, 193 F. 24 and *Schuyler v. Littlefield*, 232 U. S. 707, 58 L. ed. 806, in an attempt to limit Universal to the trust lien allowed by the Master's theory. It must be remembered, however, that although there was language in the *Brown* case indicating in that instance the opening and closing balances might not be sufficient evidence, that language must be considered in the light of the facts of that case. That was not a case where the plaintiff clearly had an equity superior to all others. There were other defrauded *cestuis* whose equities stood as high as that plaintiff, and such a situation might easily, whether rightly or not, cause a court to consider daily closing balances insufficient to raise one claimant higher than those with equal equities.

In the present instance, we need not be confused by any claim of equal equities. We have only the predomi-

nate superior equity of the minority stockholders of Universal to consider. Furthermore, in the *Brozen* case, it was shown that a check of sufficient size to completely wipe out the opening balance was certified early in the day. That situation does not exist here. There is no such affirmative evidence present to refute the daily closing balances. We have here only the mere surmise of the Special Master that a large withdrawal might have been made early some day.

As a matter of fact, when the Supreme Court considered the claims arising out of the failure of Brown & Company in the companion case of *Schuyler v. Littlefield*, it clearly recognized the propriety of using closing balances. This is disclosed by the following language appearing at the bottom of page 711 and at the top of page 712 of the Official Report:

“If the trust fund of \$9,600, was included in the check for \$266,600, then it was dissipated except to the extent of \$6,180.17, *which was the sum left to Brozen & Company's Credit at the close of business on August 24th.* And inasmuch as all of that balance was paid out early the next day, the trust fund was thereby wholly dissipated so far as the bank account was concerned.”

Before leaving this point, it should be pointed out that the Security Bank as trustee does not have an equity which can in any way compare with Universal and its minority stockholders. The Security Bank, as trustee of

the Richfield bond indenture, is representing bond holders who loaned their money to the faithless trustee Richfield, and took back a mortgage upon its properties. It is elementary, and the Master held, that the Security Bank must take title subject to the preferred trust lien of Universal. This is true because in equity, Richfield never obtained title to the moneys stolen from Universal or the goods purchased with those ill-gotten gains. Consequently, the Security Bank, which with its bondholders dealt in a contractual way with Richfield, could not obtain title by virtue of its mortgage to property which did not belong to Richfield. Security Bank and the bondholders dealt with Richfield at arm's length and with their eyes wide open. The minority stockholders of Universal were kept in ignorance of the true state of affairs and lost moneys unknowingly to a thief.

The most that can be said for the evidence introduced to attack the *prima facie* case established by the daily closing balances, is that it disclosed that Security Bank used a method of bookkeeping which did not disclose the true state of a customer's account until the end of the day. The most that can be said for the rule adopted by the Master, is that it is based upon the merest surmise, and could be true only by the most improbable happenstance. In brief, there is not one bit of affirmative evidence in the record which in any way refutes the *prima facie* case of the daily closing balances, the balances which the Master and the Security Bank admit to be the only ones that truly disclose the state of a customer's account.

II.

Where a Trustee Commingles Trust Funds With His Own, Invests a Portion of Such Funds in Property Which He Retains, and Dissipates the Remainder, the Rule in the Federal Courts Allows the Cestui a Lien Upon the Property Retained.

The above rule was established as the law in England by the well known case of *In re Oatway (Hertsley v. Oatway)* (1903), 2 Ch. D. 356.

There the trustee deposited trust moneys in his own bank account. He then withdrew a portion of the commingled moneys and invested the same in stock, taking title thereto in his own name, later dissipating the remainder of the fund in his bank account. In a creditors' action for the administration of the estate of the trustee (Mr. Oatway) the question arose as to the title to the proceeds derived from a sale of the stock. Joyce, J., held that the proceeds of the stock belonged to the beneficiaries, and stated:

“* * * It is, in my opinion, equally clear that when any of the money drawn out has been invested, and the investment remains in the name or under the control of the trustee, the rest of the balance having been afterwards dissipated by him, he cannot maintain that the investment which remains represents his own money alone, and that what has been spent and can no longer be traced and recovered was the money belonging to the trust.”

A review of the Federal cases reveals that the same rule governs in the Federal courts.

One of the earliest Federal cases establishing the rule of *Re Oatway* as the rule in the Federal courts is *Primeau v. Granfield*, 184 Fed. 480 (D. C. N. Y.) (1911).

In this case the plaintiff (Primeau) remitted moneys from the East to the defendant (Granfield) in Colorado, to be invested in mining properties. The defendant deposited the funds in his own bank account, and later paid money therefrom into the sinking of a mining shaft and the opening of a lease. Thereafter he dissipated the remainder of the account. It was held that the plaintiff was "entitled to that portion of the value of the ore *in situ*, as is represented by his contribution to the total expenses of working, plus the total rentals or royalties paid the lessor." (184 Fed. at 488.) Mr. Justice Learned Hand, then sitting upon the District Court bench, in a well reasoned opinion, expressly applied the rule of *In re Oatway*:

"A more difficult question, because it is without authority, arises in ascertaining what part of the withdrawals shall be deemed to have been Primeau's money. I shall consider each bank account as if it were a separate fund, because the parties consent to that disposition. No one disputes that, if the interlocutory decree be right, then some of Primeau's money went into the several bank accounts. Primeau by that mingling got more than a lien, and got the option either to claim a lien or to claim that he was a co-owner in the fund. The language about presumed intent in *Knatchbull v. Hallett*, *supra*, which Sir George Jessel laid down with his customary vigor, was merely a way of giving an explanation by a fiction of the right of the beneficiary to elect to regard his right as a lien. That it is a fiction appears clearly enough in this case where Granfield could have had no intention about the investments as he meant to use all the money for himself anyway. To say that in such a case he will be 'presumed' to intend to take his own money out first is merely a

disingenuous way common enough, to avoid laying down a rule upon the matter. *This fiction in Re Oatway (1903), 2 Ch. Div. 356, would have brought the usual injustice which fictions do bring, when pressed logically to their conclusion. Logically the trustee's widow, in that case, was quite right in claiming the first withdrawal, although the trustee had invested it profitably, and had subsequently wasted all of the fund which had remained in the bank. That was, of course, too much for the sense of justice of the court which awarded to the wronged beneficiary the investment, intimating that the rule in Knatchbull v. Hallett, supra, applied only where the withdrawals were actually spent and disappeared.* If to that rule be added the qualification that if the first withdrawals be invested in losing ventures, then the beneficiary is to have a lien, if he likes, till he uses up that whole investment, and then may elect to fall back for the balance upon the original mixed account from which the withdrawal was made, there is no objections, but it is a very clumsy way of saying that he may elect to accept the investment if he likes, or to reject it. The last is the only rule which will preserve to the beneficiary the option which he has when the investment is made wholly with his money. Suppose, as here, that the trustee deposits the money with his own in a bank. That is an investment. We call it a deposit, but we all know that it is only a chose in action. The beneficiary has the right at his election either to become a part owner in this chose in action, or to keep a lien upon it. Suppose he chooses to be a part owner; then, when part of it is released by payment, he is likewise a proportionate co-owner in the money paid. If that money is in turn invested he is a proportionate co-owner in that new investment, and there is no ground why as to

that investment likewise he should not have, at his election, the right to become a lienor *pro tanto*. Sir George Jessel's dictum in his judgment in *Knatchbull v. Hallett* at page 710 did not deny this, if the words are nicely observed. He says that in the case of a purchase with a mixed fund 'the *cestui que* trust, or beneficial owner, can no longer elect to take the property, because it is no longer bought with the trust money purely and simply.' No one can dissent from that statement of the law. Then he at once follows it by saying that he does have a charge, which, likewise, no one disputes; but he nowhere says that he has only a charge, and may not have *pro tanto* an ownership. Two chancellors, Lord Brougham and Lord Cottenham, had previously said that the beneficiary might have such an ownership, and later in *Re Oatway* it became apparent that, if not, then very great wrong could be done. Sir George Jessel was a very great equity judge, and no one should lightly differ with him, but there is no reason in this case to impute to him anything of the kind here suggested, or to press the fiction of a presumed intent to a conclusion which is out of harmony with the rights of a beneficiary in the analogous case where there has been no mingling of the funds." (184 Fed. at 484, 485.)"

This decision was reversed on appeal, but only upon the ground that both parties came into court with unclean hands (which point was there raised for the first time), the Circuit Court of Appeals making no mention of the point with which we are here concerned. (*Primeau v. Granfield*, 193 Fed. 911 (C. C. A. 2); *cert. den.* 225 U. S. 708, 56 Law. Ed. 1267.)

It is to be noted that in the *Primcau* case, Mr. Justice Hand went even further than the position we are asking this court to adopt in the present case. Judge Hand gave the beneficiary not merely a lien or charge upon the property retained by the wrongdoer, but a proportionate or *pro rata* share in the profits.

This is not the only time Judge Learned Hand has expressed an opinion in favor of the adoption of the rule of *In re Oatway*, by the Federal courts. In *In re O. A. Brown & Co.*, 189 Fed. 433 (D. C. N. Y.) (1911), where trust funds were mingled with the trustee's own monies, and then monies were taken out of the commingled mass and placed in stocks, Mr. Justice Hand held that the beneficiary could not follow its trust funds into the stocks because "claimants . . . failed to prove that at the time of the alleged investments any of their money remained in the account, and that is a necessary step in tracing their money into any particular part of the estate." (189 Fed. at 438.) What the holding of Judge Hand would have been if the claimants had proved, as Universal has in the present case, that at the time of the alleged investments, their money remained in the account, is shown by the following quotation from the *Brown* case approving the doctrine of *In re Oatway*:

"I need not therefore consider whether, for the purposes of establishing a lien, the beneficiary may select any earlier withdrawal which went into an investment and which has been preserved. If the general mixed fund has been wholly dissipated, it has been held that he may do so (*Re Oatway*, 1903, 2 Ch. Div. 356), and that *Knatchbull v. Hallett*, *supra*, does not limit him to a lien only where the result will be to prevent his following his money." (189 Fed. at 439.)

The *Re Oatway* doctrine was further and conclusively entrenched as the rule in the Federal courts by three Circuit Court of Appeals cases.

Brennan v. Tillinghast, 201 Fed. 609 (C. C. A. 6) (1913);

In re Pacat Finance Corporation, 27 Fed. (2d) 810 (C. C. A. 2) (1928);

Fiman v. State of South Dakota, 29 Fed. (2d) 776 (C. C. A. 8) (1928).

In *Brennan v. Tillinghast*, *supra*, the National Bank of Ironwood received, knowing itself to be insolvent, certain stock of the plaintiff as collateral security for his note. A number of the shares of this stock were wrongfully sold and the proceeds amounting to \$3,558.75 were deposited on May 1, by the Ironwood Bank, in its account with a Duluth Bank. Between May 1 and May 8, the Ironwood Bank drew drafts upon the Duluth Bank, receiving from the purchaser cash which was deposited in the Ironwood Bank's own vaults. *From the time of the deposit on May 1 (in the Duluth Bank) until the withdrawal (from the Duluth Bank) the Ironwood Bank's account with the Duluth Bank exceeded the amount of the proceeds derived from the wrongful sale of plaintiff's stock.* Upon the Ironwood Bank closing its doors, the plaintiff asked for a preferential claim. The lower court gave the plaintiff a preferential claim for the amount of the stock (less the amount of plaintiff's note to the Ironwood Bank and the amount of an overdraft). On appeal by the receiver of the Ironwood Bank the decision

of the lower court was affirmed, and the Circuit Court of Appeals for the Sixth Circuit, speaking through Judge Sanford, expressly adopted the rule of *In re Oatway*:

“It is true that in the case of blended moneys in a bank account, consisting in part of trust funds, from which there have been drawings from time to time, it has been held, in favor of the *cestui que* trust, as a presumption of law, that the sums first drawn out were from the moneys which the tort-feasor had a right to expend in his own business, and that the balance which remained included the trust fund, which he had no right to use. *In re Hallett’s Estate*, 13 Ch. D. 696, 727; *Board of Commissioners v. Strawn*, *supra*, at page 51. It is clear, however, in the first place, that this is a mere presumption, which will not stand against evidence to the contrary. *Board of Commissioners v. Strawn*, *supra*, at page 51.

*“And it is furthermore clear that this rule of presumption has no application where the evidence shows that the first moneys drawn out of the mingled fund by the tort-feasor were not in fact dissipated by him at all, but were merely transferred, in a substituted form, to another fund retained in his own possession. In such case, it must be held that the trust attaches to the substituted form in which the property is retained by the tort-feasor, and that the right to follow the trust in such form is not lost by reason of the fact that the tort-feasor thereafter draws out and spends for his own purposes the balance of the fund in which the trust money was originally mingled. The English case of *In re Oatway*, L. R. 2, Ch. 356, 359, directly sustains this view * * *.*

“In like manner we are of opinion that in the present case it must be held that the transfer by

the Ironwood Bank to its own vaults, through the cash draft transactions, of \$2807.32, of the balance standing to its credit in the Duluth Bank in which the trust fund had been mingled, did not divest the money thus transferred of its character as a trust fund, but as this money remained thereafter in its own vaults and in its own custody, and subsequently passed into the hands of the receiver as part of the cash assets of the bank, it remained subject in all respects to the trust originally impressed upon the proceeds of the sale of Brennan's stock." (201 Fed. 614, 615.)

Aside from being well reasoned, the case of *Brennan v. Tillinghast* is worthy of careful consideration from this Honorable Court because it is a later decision than any one of the six cases cited by the Security Bank as being most favorable to its position, and, furthermore, each one of the six cases relied upon by the Security Bank was cited and considered by the Sixth Circuit Court of Appeals in arriving at its decision in the *Brennan* case.

The Circuit Court of Appeals for the Second Circuit recently adopted the principle of *In re Oatway* in the case of *Re Pacat Finance Corporation*, 27 F. (2) 810, (1928). Here, trust money deposited with the Pacat Finance Corporation was placed by the Corporation in its own bank account. Pacat then drew on its own bank account to pay for lire to be sent to an Italian bank, which bank received the amount and credited Pacat. N. Bernardini State Bank sought to reclaim from the trustee in bankruptcy of the Pacat Finance Corporation the trust funds from the second commingled fund. From a decree in the lower court in favor of claimant, Pacat appealed. In

affirming the holding of the lower court it was said through Swan, J:

“* * * His contention is that his dollars are traceable into the lire credit which Pacat had with Credito Italiano at the date of the bankruptcy. On December 14th, Pacat drew its check on its account in the National Park Bank to pay for 1,000,000 lire to be sent to Credito Italiano through the Banca D'Italia. This sum was received by Credito Italiano and credited to Pacat. On December 15th and 16th Pacat again drew checks which purchased 2,000,000 lire that were deposited to its credit with Credito Italiano. *While Berardini's dollars cannot literally be traced into any of these lire credits, the applicable principle is that stated by Joyce, J., in In re Oatway,* * * *.

“* * * *It is, in my opinion, equally clear that when any of the money drawn out has been invested, and the investment remains in the name or under the control of the trustee, the rest of the balance having been afterwards dissipated by him, he cannot maintain that the investment which remains represents his own money alone, and that what has been spent and can no longer be traced and recovered was the money belonging to the trust.*”

Accord: Brennan v. Tillinghast, 201 F. 609, 614 (C. C. A. 6); Primeau v. Granfield, 184 F. 480, 484 C. C. S. D. N. Y.); *In re A. O. Brown & Co.*, 189 F. 432, 439 (D. C. S. D. N. Y.); *City of Lincoln v. Morrison*, 64 Neb. 822, 90 N. W. 905, 57 L. R. A. 885.

“Consequently the lire credits created by withdrawals from the National Park Bank, when Pacat's account therein was composed in part of Berardini's

checks received and held by Pacat on constructive trust, were in equity subject to a lien or charge in favor of Berardini. * * *” (27 Fed. (2), 813, 814.)

Even the most casual reading of the opinions in the cases of *Brennan v. Tillinghast*, *supra*, and *re Pacat Finance Corporation*, *supra*, reveals that, without a doubt, the principle of *In re Oatway* is law in the Federal courts. The brief for the Security Bank attempts to distinguish those cases upon the ground that there the commingled fund was merely transferred from one fund to another, that is, “*the money still remained money*” (Brief for Security Bank at page 60); whereas, in the present case and the *Oatway* case a portion of the commingled fund was converted *from money into property*.

It is submitted that the distinction attempted to be drawn by the Security Bank is not only unfounded in authority,

Primeau v. Granfield, 184 Fed. 480 (mixed fund converted into real estate, and lien allowed).

See:

In re A. O. Brown & Co., 189 Fed. 432 (mixed fund converted into stock, and lien allowed),

but also does violence to an elementary principle of equity. Mr. Justice Dewey, while holding for the *cetui* in a case analogous to the present one, summarized the applicable equitable principle:

“* * * There is a general equitable rule that, where a wrongdoer knowingly mingles the property of another with his own in such a manner as it becomes indistinguishable, the true owner may claim

the whole mass, or, if it has been disposed of, *may follow it or its proceeds as the case may be*, as long as he can trace them for the purpose of fastening an equitable lien upon the property of which he has been dispossessed.” (*Fiman v. State of South Dakota*, 29 Fed. (2) 776, 780, C. C. A. 8 (1928), cert. den. 73 L. ed. 987.

The equity of the wronged *cestui* is equally as great in the case where a portion of the commingled money is converted from money into property, as it is in the situation where a portion of the mingled monies is transferred from one fund to another fund and retained in the form of money. It is absurd to declare that the *cestui's* lien is to be allowed “where the money remains money” and is not to be allowed in the case where the money is converted into a potato.

The brief for the Security Bank contends that the United States Supreme Court has expressly repudiated the doctrine of *In re Oatway*. In support of this contention are cited the cases of *Peters v. Bain*, 133 U. S. 670, 33 L. ed. 696 (1889), and *Schuyler v. Littlefield*, 232 U. S. 707, 58 L. ed. 806 (1913).

The proper basis for the Supreme Court's refusal in the case of *Peters v. Bain* to allow the *cestui* a preferred claim is not because it was opposed to the principle later set forth in the case of *In re Oatway*, but because the proper foundation for the application of the *In re Oatway* principle was not laid by the *cestui* in the *Peters v. Bain* case. In the principle case, there is absolutely no doubt whatever that a portion of the *mixed* fund was utilized by Richfield for the purchase of the property upon which Universal claims a lien. In *Peters v. Bain* the *cestui* was unable to prove that a portion of the *mixed* fund went

toward the purchase of the property. That this is the proper distinction between *Peters v. Bain* and the present case is seen from the following quotation from the opinion of Mr. Justice Waite rendered when the case was before the Circuit Court of Appeals:

“The property in the second class, however, occupies a different position. *There the purchases were made with moneys that cannot be identified as belonging to the bank. The payments were all, so far as now appears, from the general fund then in the possession and under the control of the firm. SOME OF THE MONEY OF THE BANK MAY HAVE GONE INTO THIS FUND.*” (33 L. ed. at 699.)

This distinction is further supported by the following statement of Mr. Chief Justice Fuller in speaking for the Supreme Court:

“It was said by Mr. Justice Bradley in *Frelinhuyzen v. Nugent*, 34 Fed. Rep. 229, 239: ‘Formerly the equitable right of following misapplied money or other property in the hands of the parties receiving it depended upon the ability of identifying it; the equity attaching only to the very property misapplied. This right was first extended to the proceeds of the property, namely, to that which was procured in place of it by exchange, purchase or sale. But if it became confused with other property of the same kind, so as not to be distinguishable, without any fault on the part of the possessor, the equity was lost. Finally, however, it has been held as the better doctrine that confusion does not destroy the equity entirely, but converts it into a charge upon the entire mass, giving to the party injured by the unlawful diversion a priority of right over the other creditors of the possessor. This is as far as the rule has been

carried. The difficulty of sustaining the claim in the present case is, that *it does not appear that the goods claimed,—that is to say, the stock on hand, finished and unfinished—were either in whole or in part the proceeds of any money unlawfully abstracted from the bank.*' THE SAME DIFFICULTY PRESENTS ITSELF HERE, and while the rule laid down by Mr. Justice Bradley has been recognized and applied by this court, *National Bank v. Insurance Company*, 104 U. S. 54, 67, and cases cited, yet, as stated by the Chief Justice, 'purchases made and paid for out of the general mass cannot be claimed by the bank unless it is shown that its own moneys then in the fund were appropriated for that purpose.' And this the evidence fails to establish as to any other property than that designated in the decree * * *." (33 L. ed. at 704.)

Schuyler v. Littlefield, 232 U. S. 707, 58 L. ed. 806 (1913), the case in which the United States Supreme Court for the second time supposedly refused to adopt the rule of *In re Oatway*, is distinguished from the principal case and *In re Oatway* upon the same grounds as *Peters v. Bain*. The statement of the Supreme Court in the *Schuyler* case:

"But the record fails to show when the \$266,600 was deposited, and it also fails to show with the requisite certainty the particular use made by Brown & Company of that money." (58 L. ed. at 808.)

as well as the following language found in the opinion in the Circuit Court of Appeals:

"As we have seen, the Hanover Bank had in its possession various surpluses of collaterals above the amount of the several notes for which such collateral was pledged, some of these collaterals were paid for

by checks drawn on the Hanover Bank and paid on the 24th, and it is contended that a lien for the trust funds is established against the surpluses of collaterals so purchased. *But there is nothing to trace claimant's money into any particular stocks or bonds, or into the collateral put up against any particular loan.* * * *

“The same court which decided *Smith v. Mottley*, however, subsequently held, in *Board of Commissioners v. Strawn*, 157 Fed. 49, 84 C. C. A. 553, 15 L. R. A. (N. S.) 1100, that *the mere fact that the misuse of a trust fund has gone to swell, in one form or another, the general assets of a bankrupt, is not enough to charge a lien on such assets; and that, to impress a trust upon the property of a tortfeasor who has used the trust fund in his private affairs, it must be traced in its original shape or substituted form.*” (*In re A. O. Brown*, 193 F. 24, 28, 29 (C. C. A. 2) (1912).)

clearly indicates that the mixed fund may have been completely exhausted before any part of the bankrupt account was converted into property. Obviously in such a case no one would contend that the principle of *In re Oatway* was applicable.

As conclusive evidence of the fact that neither *Peters v. Bain* nor *Schuyler v. Littlefield* settle the rule in the Federal courts as being contrary to the principle of *In re Oatway*, we call the attention of this Honorable Court to the fact that in none of the cases decided after those two cases (cited either in the brief for the Security Bank or brought to light by our research) did the courts feel that the *Peters v. Bain* or the *Schuyler* case settled the rule to be applied to facts similar to those with which we are here concerned.

There remain to be considered three other cases which are often cited in support of the proposition that the doctrine of *In re Oatway* is not applied in the Federal Courts.

Board of Commissioners v. Strawn, 157 Fed. 49
(C. C. A. 6th) (1907);

Empire State Surety Co. v. Carroll, 194 Fed. 593
(C. C. A. 8th) (1912);

In re City Bank of Dowagiac, 186 Fed. 413 (D. C. Michigan) (1910).

It is submitted that a careful reading of the opinion in each of these cases will reveal that the manner in which we have distinguished *Peters v. Bain* is equally applicable to each of them. Furthermore, it is interesting to note that *Brennan v. Tillinghast*, *supra*, a later case than the *Strawn* case, but arising in the same Circuit Court of Appeals held squarely in favor of the view urged by Universal in this controversy. The *Empire State Surety* case, *supra*, which arose in the Eighth Circuit Court of Appeals, is controlled by the case of *Fiman v. State of South Dakota*, *supra*, a later decision in the same Circuit holding squarely in our favor. The *Dowagiac* case arising in a Michigan District Court, is obviously controlled by *Brennan v. Tillinghast*, the latest decision upon our facts in the Sixth Circuit.

Board of Commissioners v. Strawn, *supra*, is of interest in that it not only serves to bear out the distinction between *Peters v. Bain* on the one hand, and the present case and the *Oatway* doctrine in the other, but it cites *Peters v. Bain* for the proposition which it really holds; namely, that where the *cestui* could not prove that a part of the MIXED FUND had been converted into property, then

he would not be allowed a lien. In the *Strawn* case, the court said:

“The assumption that all of these bills and notes were bought and paid for by the actual application of the money in the vaults of the bank with which the trust fund money has been mingled, or for loans made out of that fund, is not borne out by the evidence. Some of the transactions did not involve the actual payment of any money out of the funds of the bank, inasmuch as the proceeds would be passed to the credit of the party procuring the discount. In some cases the credit thus obtained was possibly drawn upon afterwards. The bank officers were unable to point out a single piece of this commercial paper in the receiver’s possession as having been acquired by the actual use of the blended money of the bank and the county.” (157 Fed. at 53.)

“Without going more into detail, it is enough to say that the evidence does not satisfy us that all or any large part of this mass of paper was acquired by the use of the moneys of the bank with which this trust fund had been mingled But aside from this view of the evidence, the claim to a general charge upon any and all property acquired by the bank, through the use of the general funds of the bank with which this trust fund had been blended, is not supported by the weight of authority, nor do the cases decided by this court go so far. That the misuse of this trust fund has gone to swell in one form or another, the general assets of the bank is not enough to charge the whole with a lien, will not be seriously contested. The cases which deny such a contention are numerous.” (157 Fed. at 54.)

“Peters v. Bain, 133 U. S. 671, 678, 693, 10 Sup. Ct. 354, 33 L. Ed. 696, is a very close authority

upon the facts of this case. * * * It was sought, also, to impress a lien upon other property which has been 'paid for by the firm out of the general mass of moneys in their possession, and which may or may not have been made up in part of what had been wrongfully taken from the bank.' " (157 Fed. at 55.)

If the presumption established in *Knatchbull v. Hallett*, L. R. 13 Chancery Division, 696 (Court of Appeal) (1880), and adopted by the Federal Courts, *Central Natl. Bank v. Conn. Mut. Life Ins.*, 14 U. S. 54, 26 L. ed. 693, is carried to its logical extreme, it is obvious that in a factual situation such as that presented in our case, the *cestui* would not be entitled to a lien upon the property purchased with a portion of the mixed funds. However, this presumption, if it be a presumption, was adopted by the court in *Hallett's* case for the benefit of the *cestui* as against a wrongdoing trustee. It was never intended to be invoked for the purpose of defeating the rights of the innocent beneficiary and protecting the wrongdoing trustee.

This view has been adopted by the well reasoned authorities upon this matter:

Primeau v. Granfield, *supra*;

Brennan v. Tillinghast, *supra*;

In Re Pacat Finance Corporation, *supra*;

and in 27 *Harvard Law Review*, 125, 129, we find the following statement by Professor Austin Wakeman Scott:

"This is, of course, a pure fiction, and, as usually happens when a proper result is reached by fictitious reasoning, has led to erroneous results in other cases. It seems to be thought necessary to show in what

part of the commingled fund the claimant's money is to be found; and as it is impossible actually to distinguish the claimant's contribution, the courts have resorted to a presumption as to the intent of the wrongdoer, although there is no reason to suppose that he had any particular intent, and no reason for allowing his intent to affect the claimant's rights. *The claimant ought . . . to have an interest in what is left, not because of any intent of the wrongdoer, but because the wrongdoer, whatever his intent, should not be allowed, by taking away a part of the fund, to deprive the claimant of his lien on, or share of, the rest of the fund.*"

Although we recognize that the decisions of the California state courts upon our question are not absolutely controlling in an action in the Federal Courts:

"Moreover, in a federal court of equity, we must decide cases in accordance with our view of the general principles of equity jurisprudence. *Kuhn v. Fairmont Coal Co.*, 215 U. S. 349, 363, 30 S. Ct. 140, 54 L. Ed. 228; *Russell v. Southard*, 12 How. 139, 13 L. Ed. 927; *Neves v. Scott*, 13 How. 268, 14 L. Ed. 140. The decisions of the particular state in which the cause of action arose are to be followed only in so far as they conform to established principles of equitable jurisprudence." (*Elmer v. Kemp*, 67 Fed. 2d 948, 952 (C. C. A. 9) (1933).)

we take the liberty of calling to the attention of this Honorable Court the well reasoned opinion of the California Supreme Court in *Mitchell v. Dunn*, 211 Cal. 129 (1930).

There the California court reached the same result as did the English court in *Re Oatway* and Mr. Chief Justice Waste, in speaking for the California Supreme Court, said:

“The only question left to determine was whether the sum withdrawn was from the trust funds or from the personal funds of appellant. If the presumption that withdrawals must be deemed to have been from the personal part of the commingled fund applies to such a case, it is clear that no trust can be enforced against the Jefferson Street property.

“We are of the opinion that the presumption mentioned has no application to a case such as this. The presumption is nothing more than a fiction created to assist the *cestui*, not to injure him. It was created to assist *cestuis* in following the trust property, not to hinder them. The basis of the presumption is that it will be presumed that a trustee acts honestly, and not dishonestly.” (211 Cal. at 134.)

“The appellant herein wrongfully dissipated the trust funds in her possession and then replaced the funds wrongfully taken. Then, after purchasing the real property herein involved, appellant dissipated the entire fund. Can appellant, after having been guilty of such conduct over a period of years, come before the court and contend that, because it must be presumed she acted rightfully on November 3, 1934, the only tangible property purchased from the fund and still remaining in her possession must be presumed to have been purchased with personal funds, and that

all the money that was dissipated by her must be presumed to have been trust funds? To state the proposition is to refute it. In fact, if we are to presume the appellant acted rightfully, it would be far more consonant with such a presumption to say that the property purchased was purchased with trust funds, and the money dissipated was personal funds. At any rate, the presumption in reference to withdrawals, in a contest between the *cestui* and trustee, based as it is, on a theory of right-doing, cannot be indulged in to defeat the *cestui's* right of recovery when all the evidence shows a consistent course of conduct amounting to wrong-doing. To permit the presumption to be used for that purpose would be to permit its use as a shield for wrong-doing, and that we are not inclined to do." (211 Cal. at 135.)

Although the language of some of the Federal decisions ostensibly tends to support a contrary rule, it is respectfully submitted that a careful scrutiny of the facts and holding in such cases indicates, either that no part of the mixed fund actually went into the purchase of the property sought to be impressed with a lien, or at most, that the decision was based upon a hasty and ill considered application of the so-called presumption established in *Hallett's* case. We feel that in those Federal cases presenting the *actual factual setup confronting us in the case at bar*, that it is evident that the English rule as set forth in *Re Oatway* has been adopted by, and is, the rule in the Federal courts.

Conclusion.

In conclusion, may we again direct the attention of this Honorable Court to the fact that the method of obtaining the lowest bank balance, adopted by the Special Master, has resolved all doubt in favor of the wrongdoer Richfield and the trustee of its bond indenture, Security Bank, at the expense of the innocent minority stockholders of Universal.

We believe an examination of the record discloses that there is absolutely no evidence to support the Master's theory and our research, and apparently the research of other counsel, does not disclose any cases which support that theory. There are, however, definite statements in the cases as to the burden of proof in matters of this kind. That burden, we confidently believe, was maintained by Universal when the daily closing bank balances were shown. The evidence of posted balances certainly cannot be considered as refuting that *prima facie* case.

With respect to the argument of Security Bank, that this Honorable Court should not allow Universal to trace its stolen moneys out of the Richfield bank account into properties purchased therewith, we submit that not only the adoption of the rule of *in re Oatway* by the Federal Courts, but every consideration of justice and equity requires that the conclusion of the Special Master and the learned Trial Court upon this point be confirmed.

Respectfully submitted,

DAVID R. FARIES,

*Amicus Curiae on Behalf of Universal Consolidated Oil
Company.*

DON F. TYLER,

LEONARD S. JANOFSKY,

Of Counsel.

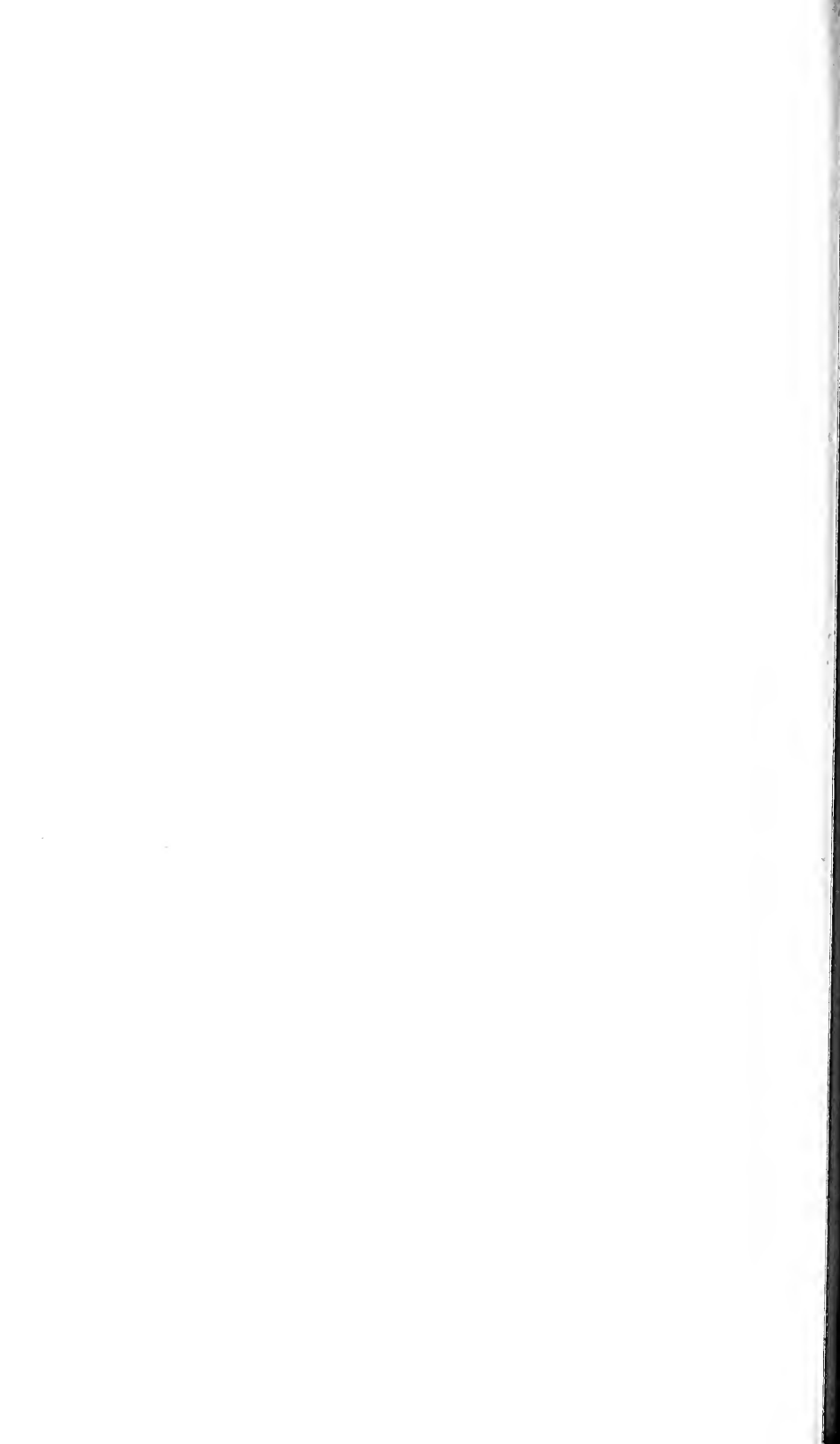

11

**In the United States
Circuit Court of Appeals
For the Ninth Circuit.**

THE REPUBLIC SUPPLY COMPANY OF CALIFORNIA,
a corporation,
Complainant,
vs.
RICHFIELD OIL COMPANY OF CALIFORNIA, a corporation,
Defendant.

SECURITY-FIRST NATIONAL BANK OF LOS ANGELES, as Trustee, **GEORGE ARMSBY, F. S. BAER, HARRY J. BAUER, STANTON GRIFFIS, ROBERT E. HUNTER** and **ALBERT E. VAN COURT,** known and designated as **Richfield Bondholders' Committee,**
Appellants and Cross-Appellees,
vs.

UNIVERSAL CONSOLIDATED OIL COMPANY, a California corporation,
Intervenor, Appellee and Cross-Appellant,

THE CHASE NATIONAL BANK OF THE CITY OF NEW YORK, Receiver for Pan American Petroleum Company, a corporation, **BANK OF AMERICA,** a corporation, **PAN AMERICAN PETROLEUM COMPANY,** a corporation, **WILLIAM C. McDUFFIE,** as Receiver for Pan American Petroleum Company, a corporation, **RICHFIELD OIL COMPANY OF CALIFORNIA,** a corporation, **UNITED STATES OF AMERICA, THE REPUBLIC SUPPLY COMPANY OF CALIFORNIA,** a corporation, **CITIES SERVICE COMPANY,** a corporation, **ROBERT C. ADAMS, THOMAS B. EASTLAND, EDWARD F. HAYES,** and **RICHARD W. MILLAR,** known and designated as Pan American Bondholders' Committee, **G. PARKER TOMS, ROBERT C. ADAMS, F. S. BAER, ROBERT E. HUNTER, HENRY S. MCKEE** and **RICHARD W. MILLAR,**

(Continued on Inside Cover.)

PETITION OF APPELLEE WILLIAM C. McDUFFIE, AS RECEIVER OF RICHFIELD OIL COMPANY OF CALIFORNIA, FOR REHEARING.

known and designated as Richfield Pan American Reorganization Committee, WILLIAM C. McDUFFIE, as Receiver of Richfield Oil Company of California, SECURITY-FIRST NATIONAL BANK OF LOS ANGELES, a national banking association, PACIFIC AMERICAN COMPANY, a corporation, AMERICAN COMPANY, a corporation, MANUFACTURERS TRUST COMPANY OF NEW YORK, a corporation, CITIZENS NATIONAL TRUST & SAVINGS BANK OF LOS ANGELES, a national banking association, FIRST NATIONAL BANK AND TRUST COMPANY OF SEATTLE, a national banking association, CONTINENTAL ILLINOIS BANK AND TRUST COMPANY, a corporation, THE FIRST NATIONAL BANK OF CHICAGO, a national banking association, CHEMICAL NATIONAL BANK AND TRUST COMPANY, a national banking association, and CALIFORNIA BANK, a corporation, M. W. LOWERY, HENRY S. McKEE, O. C. FIELD, R. R. TEMPLETON, known and designated as Richfield Unsecured Creditors' Committee.

Appellees.

HENRY F. PRINCE,
HOMER D. CROTTY,
HERBERT F. STURDY,
DAVID P. EVANS,
GIBSON, DUNN & CRUTCHER,
By HENRY F. PRINCE,

634 South Spring St., Los Angeles, California,
*Solicitors for Appellee, William C. McDuffie, as Receiver
of Richfield Oil Company of California.*

TOPICAL INDEX.

PAGE

I.

It is respectfully and earnestly submitted that the decision of this court is in error in failing to recognize and apply the basic principles of federal equity receivership established by the United States Supreme Court and by the Circuit Courts of Appeal in other circuits, which may be briefly summed up in the phrase "equality is the highest equity"..... 7

(a) The primary object of a federal equity receivership is to prevent one claimant recovering at the expense of the others, and to bring about a pro rata distribution between claimants. As between claimants "equality is the highest equity" 7

(b) There is no preference, priority of "equity" in favor of claimants who become such by reason of fraud as compared with other creditors..... 10

(c) Against the receiver and other creditors of an insolvent trustee, the burden of tracing trust funds into the hands of the receiver is absolutely, continuously and unequivocally on the cestui, and all doubts and possibilities are resolved in favor of the receiver, in order that there may be an equitable, pro rata distribution of the entire estate among all claimants, including the cestui..... 15

(d) The receiver, who is an officer of the court, and the other creditors who have done no wrong to Universal must not be confused with the insolvent tort feason..... 23

II.

It is respectfully submitted that it is established by the decisions requiring the cestui to prove the "low balance" (Part (a) below), by reason and banking practice (Part (b) below), and by the unanimous authority of five decisions passing directly on the point, two of them affirmed by the United

- States Supreme Court (Part (c) below). That when a claimant in receivership is seeking to trace trust funds through a commingled account, merely showing the overnight balances of such account is not prima facie or any evidence of the "low balance" of such account. The claimant has the absolute burden of proving the actual "low balance" at all times in the account, and that burden never shifts to the receiver, for to shift it would be to grant an improper preference under the guise of tracing trust funds..... 29
- (a) When the low balance theory of tracing is applied to an account in which trust funds and other funds are commingled, the burden is on the cestui to prove the actual low balance continuing in the account at all times between the time the trust funds were commingled in the account and the time to which the cestui is seeking to trace such funds 29
- (b) From the standpoint of banking practice and reason, the overnight balances of a bank account are neither prima facie evidence, nor in fact, any evidence at all that the balance in the account did not fall below the closing balance at some time during the preceding day, especially where the amount of checks and deposits entering into the account each day is in evidence..... 33
- (c) It is respectfully and earnestly submitted that not only does banking practice, reason and common sense require that the overnight balances be not taken to fix the low balances in the account when the amount of checks and deposits each day are known and in evidence, but that unanimous weight of authority requires that in tracing trust funds against an insolvent estate overnight balances of a bank account be not accepted as prima facie or any evidence of the low balance of the account during the active daytime periods intervening..... 41

III.

The Supreme Court of the State of California has established as a rule of property for that state that as against creditors of a trustee ex maleficio the cestui has no interest in a bank account of the trustee in which funds of the cestui and trustee have been commingled after checks to the amount of the cestui's funds in the account have been charged against the account. Under this rule of property and the facts established in this case, Universal had no interest in the Richfield bank account at the time the several investments, which are the subject of this proceeding, were made and consequently could have no interest in the investments. As both the bank account and all of the properties involved are properties in the State of California, and in most cases are interests in real property in the State of California, the above California rule of property should and must be followed by the federal courts 64

IV.

Under the circumstances of this case, when funds of a cestui are commingled in a single bank account with funds of the tortfeasor trustee and investments are later made from said bank account, the cestui cannot claim any of such investments at the expense of the other creditors against the trustee's insolvent estate unless the cestui sustains the burden of proving (1) that trust funds remained in the account at the time the investment was made; and (2) that the trust funds so remaining in the account were in fact (and not merely presumptively) appropriated for the purpose of making the particular investment. It is submitted that Universal has not sustained the burden of proof with respect to either of these elements 81

Conclusion 91

TABLE OF AUTHORITIES CITED.

CASES.	PAGE
Acheson Co., In re J. M., 170 Fed. 427.....	15, 17, 19
Adams v. Champion, 79 L. Ed. Adv. 366.....	11, 23, 25
American Employers' Inc. Co. v. Maynard, 226 N. W. 686.....	72
Beard v. Independent District of Pella City, 88 Fed. 375.....	74
Bevan v. Citizens National Bank of Lebanon, 19 Ky. Law Rep. 1261.....	82
Blumenfeld v. Union Nat. Bank, 38 Fed. (2) 455.....	29, 30
Board of Commissioners v. Strawn, 157 Fed. 49.....	26, 62, 82
Bogena & Williams, In re, 76 Fed. (2) 950.....	16, 22, 30
Borman et al. v. Sullivan, 77 Fed. (2) 342.....	29, 31, 32, 36, 42
Brennan v. Tillinghast, 201 Fed. 609.....	86
Bright v. King, 20 Ky. Law Rep. 186.....	82
Brown, In re, 193 Fed. 24.....	41, 51, 52, 53, 55, 62, 82
Brown & Co., In re, 193 Fed. 30.....	41, 82, 89, 92
Brown & Co., In re A. O., 189 Fed. 432.....	41, 48, 50, 82, 85, 90
Brunsing, Tolle & Postel, In re, 169 Fed. 668.....	12
Burnham v. Barth, 62 N. W. 96.....	36, 82
Byrne, In re, 32 Fed. (2) 189.....	23, 24, 25
City Bank, In re, 186 Fed. 413.....	82
City of Spokane v. First National Bank of Spokane, 68 Fed. 982	82
Clark v. Bacorn, 116 Fed. 617.....	9
Connolly v. Lang, 68 Fed. (2) 199.....	41, 59
Cook v. Elliott, 73 Fed. (2) 916.....	16
Davis v. Elmira Savings Bank, 161 U. S. 275.....	75
Edward Hines Yellow Pine Trustees v. Martin, 268 U. S. 458, 69 L. Ed. 1050.....	76, 77
Elmer v. Kemp, 67 Fed. (2d) 948.....	74
Empire State Surety Co. v. Carroll County, 194 Fed. 593.....	82
Farmers' Bank v. Bailey, 221 Ky. 55, 297 S. W. 938.....	27

	PAGE
Ferris v. Van Vetcher, 73 N. Y. 113.....	82, 85
Fiman v. State of South Dakota, 29 Fed. (2) 776.....	85, 86
First Nat. Bk. of Princeton v. Littlefield, 226 U. S. 110.....	41
First National Bank of Princeton v. Littlefield, 226 U. S. 110, 57 L. Ed. 145.....	53
First National Bank of Princeton v. Littlefield, 226 U. S. 110, 57 L. Ed. 145.....	41, 53, 82
First Nat. Bank of Princeton, Ex parte, A. O. Browne & Co., In re, 189 Fed. 432.....	41, 47, 82
First Nat. Bk. of St. Petersburg v. City of Miami, 69 Fed. (2) 346	16, 21
Gianella v. Momsen, 63 N. W. 1018.....	82
Grand Forks County v. Baird, 54 N. Dak. 315, 209 N. W. 782..	27
Gunter v. Janes, 9 Cal. 643.....	65
Harmer v. Rendleman, 64 Fed. (2) 422.....	16, 20
Harry E. Jones, Inc. v. Kemp, 74 Fed. (2) 623.....	23, 24
Hawaiian Pineapple Co. v. Browne, 69 Mont. 140, 220 Pac. 1114	27
Israel v. Woodruff, 299 Fed. 454.....	27
Jennings v. U. S. Fidelity & Guaranty Co., 79 L. Ed. Adv. 355..	63
John Deere Plow Co. v. McDavid, 137 Fed. 802.....	74
Jones v. Harrison, 7 Fed. (2) 461; 270 U. S. 652.....	76
Jones v. Harrison, 7 Fed. (2d) 461, certiorari denied; 270 U. S. 652	80
Jones v. Readey, 270 U. S. 652.....	80
Kershaw v. Jenkins, 71 Fed. (2) 647.....	16, 29, 30
Knatchbull v. Hallett, 13 Ch. Div. 696.....	65, 71
Lathrop v. Bampton, 31 Cal. 17.....	12
Lincoln v. First National Bank of Cadiz, 172 U. S. 425.....	75
Lucas County v. Jamison, 170 Fed. 338.....	12
Marshburn v. Williams, 15 Fed. (2) 589.....	41, 42, 44
Maryland Casualty Co. v. Williams, 159 So. 242.....	23, 25, 26
Matthews' Sons, Inc., In re A. D., 238 Fed. 785.....	16, 20

	PAGE
Merchants & Farmers Bank v. Austin, 48 Fed. 25.....	12
Meyers v. Baylor University, 6 S. W. (2) 393.....	27
Mitchell v. Dunn, 211 Cal. 129.....	64, 71
Moore v. Jones, 63 Cal. 12.....	85
Mulligan, In re, 116 Fed. 715.....	30, 63, 75
Multnomah County v. Oregon Nat. Bank, 61 Fed. 912....	12, 14, 36
National Bank v. Insurance Co., 104 U. S. 54.....	35, 65
Nixon State Bank v. First State Bank of Bridgeport, 60 So. 868	41, 45, 47
Noble v. Noble, 198 Cal. 129.....	74
Oatway, In re, 2 Ch. Div. 356.....	86, 88
Orcutt v. Gould, 117 Cal. 315.....	30
Pacat Finance Corp., 27 Fed. (2) 810.....	85
People v. California Safe Deposit & Trust Co., 175 Cal. 756....	66
Peters v. Bain, 133 U. S. 670.....	82, 83
Philadelphia Nat'l Bank v. Dowd, 38 Fed. 172.....	72
Pickens v. Merriam, 274 Fed. 1.....	76, 78
Poole v. Elliott, 76 Fed. (2) 772.....	16, 72
Porter v. Boyd, 171 Fed. 305.....	9
Pottorff v. Key, 67 Fed. (2) 833.....	11, 12
Primeau v. Granfield, 184 Fed. 480.....	47, 54, 85
Rugger v. Hammond, 163 Pac. 408.....	72
Scandinavian-American Bank v. Sabin, 227 Fed. 579.....	76, 78
Schuyler v. Littlefield, 232 U. S. 707, 58 L. Ed. 806.....	15, 16, 17, 18, 41, 89, 90, 93
Schuyler, Chadwick & Burnham, Ex parte, A. O. Browne & Co., In re, 189 Fed. 432.....	41, 54, 82
S. L. & S. F. R. Co. v. Spiller, 274 U. S. 304.....	20
Slater v. Oriental Mills, 18 R. I. 352, 27 Atl. 443.....	11, 13
Smith v. Mottley, 150 Fed. 266.....	61
Standish v. Babcock, 50 N. J. Eq. 628.....	82

	PAGE
Stilson v. First State Bank, 129 N. W. 70.....	12, 70
First Nat. Bk. of Princeton v. Littlefield, 226 U. S. 110.....	41, 82
Taylor v. Morris, 163 Cal. 717.....	85
Texas & Pac. Ry. Co. v. Pottorff, Rec'r, 291 U. S. 245, 78 L. Ed. 777, 786, note 19.....	11, 13, 15, 17
Titlow v. McCormick, 236 Fed. 209.....	15, 17, 18, 93
United States v. Pan American Petroleum Company, 55 Fed. (2) 753.....	10
Wisdom v. Keen, 69 Fed. (2) 349.....	11, 23
Wisdom v. Keen, 69 Fed. (2) 349.....	11

TEXT BOOKS AND ENCYCLOPEDIAS.

1 Bowles, Modern Law of Banking, p. 190.....	12, 15
Hughes Federal Practice, vol. 6, sec. 3712, p. 238-9.....	76
Hughes, Federal Practice, vol. 6, sec. 3715, p. 248.....	78

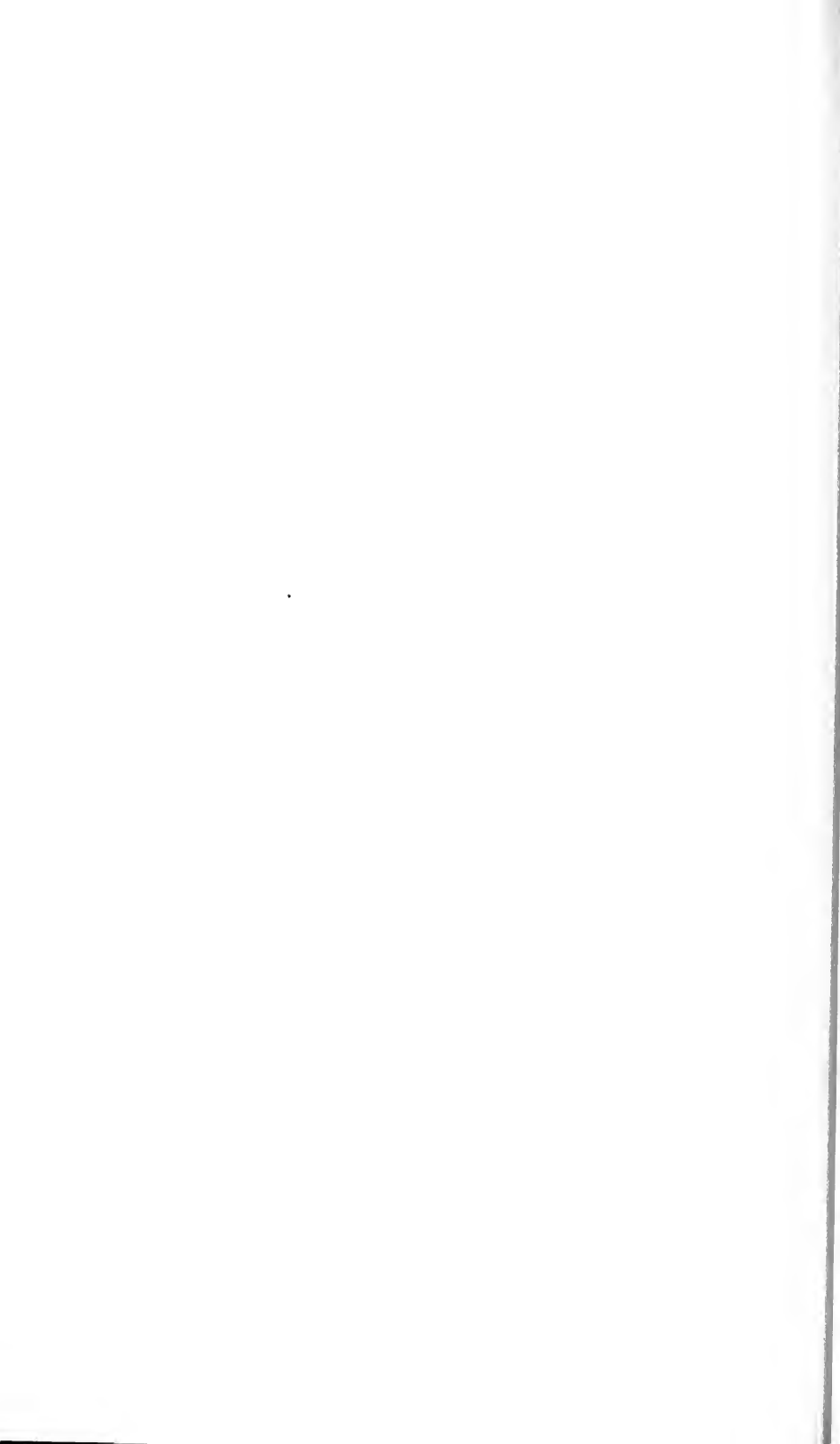

In the United States
Circuit Court of Appeals
For the Ninth Circuit.

THE REPUBLIC SUPPLY COMPANY OF CALIFORNIA,
a corporation,

Complainant,

vs.

RICHFIELD OIL COMPANY OF CALIFORNIA, a corporation,
Defendant.

SECURITY-FIRST NATIONAL BANK OF LOS ANGELES, as Trustee, **GEORGE ARMSBY, F. S. BAER, HARRY J. BAUER, STANTON GRIFFIS, ROBERT E. HUNTER** and **ALBERT E. VAN COURT,** known and designated as Richfield Bondholders' Committee,

Appellants and Cross-Appellees,

vs.

UNIVERSAL CONSOLIDATED OIL COMPANY, a California corporation,

Intervenor, Appellee and Cross-Appellant,

THE CHASE NATIONAL BANK OF THE CITY OF NEW YORK, Receiver for Pan American Petroleum Company, a corporation, **BANK OF AMERICA,** a corporation, **PAN AMERICAN PETROLEUM COMPANY,** a corporation, **WILLIAM C. McDUFFIE,** as Receiver for Pan American Petroleum Company, a corporation, **RICHFIELD OIL COMPANY OF CALIFORNIA,** a corporation, **UNITED STATES OF AMERICA, THE REPUBLIC SUPPLY COMPANY OF CALIFORNIA,** a corporation, **CITIES SERVICE COMPANY,** a corporation, **ROBERT C. ADAMS, THOMAS B. EASTLAND, EDWARD F. HAYES, and RICHARD W. MILLAR,** known and designated as Pan American Bondholders' Committee, **G. PARKER TOMS, ROBERT C. ADAMS, F. S. BAER, ROBERT E. HUNTER, HENRY S. MCKEE** and **RICHARD W. MILLAR,** known and designated as Richfield Pan American Reorganization Committee, **WILLIAM C. McDUFFIE,** as Receiver of Richfield Oil Company of California, **SECURITY-FIRST NATIONAL BANK OF LOS ANGELES,** a national banking association, **PACIFIC AMERICAN COMPANY,** a corporation, **AMERICAN COMPANY,** a corporation, **MANUFACTURERS TRUST COMPANY OF NEW YORK,** a corporation, **CITIZENS NATIONAL TRUST & SAVINGS BANK OF LOS ANGELES,** a national banking association, **FIRST NATIONAL BANK AND TRUST COMPANY OF SEATTLE,** a national banking association, **CONTINENTAL ILLINOIS BANK AND TRUST COMPANY,** a corporation, **THE FIRST NATIONAL BANK OF CHICAGO,** a national banking association, **CHEMICAL NATIONAL BANK AND TRUST COMPANY,** a national banking association, and **CALIFORNIA BANK,** a corporation, **M. W. LOWERY, HENRY S. MCKEE, O. C. FIELD, R. R. TEMPLETON,** known and designated as Richfield Unsecured Creditors' Committee.

Appellees.

PETITION OF APPELLEE WILLIAM C. McDUFFIE, AS RECEIVER OF RICHFIELD OIL COMPANY OF CALIFORNIA, FOR REHEARING.

To the Honorable United States Circuit Court of Appeals for the Ninth Circuit, and the Judges Thereof:

Appellee, William C. McDuffie, as Receiver of Richfield Oil Company of California, representing as he does the more than six thousand persons who filed claims in the receivership of Richfield, respectfully but earnestly petitions for a rehearing of said cause by this Court on the bill in intervention and claim of Universal Consolidated Oil Company upon all of the grounds hereinafter set forth.

In support of this petition we respectfully submit that the decision which this Court has rendered in the pending cause is erroneous in each of the matters below specified.

1. It fails to recognize and give effect to the well established basic rules in equity receiverships (a) that the primary object of such receiverships is to bring about a *pro rata* distribution between claimants, and that as between claimants "equality is the highest equity," (b) that there is no preference, priority or "equity" in favor of claimants who become such by reason of fraud as compared with other creditors, (c) that a fraud claimant participates in the estate *pro rata*, solely as a general creditor, unless such fraud claimant has sustained with evidence the burden of absolutely identifying his property or its substitute in the hands of the receiver, with every doubt

or possibility resolved in favor of the receiver, in order that equality of distribution may be preserved, and (d) that the receiver, who is an officer of the court, and the other creditors who have done no wrong to the fraud claimant, must not be confused with the insolvent tortfeasor.

2. It fails to recognize and give effect to the rule established by reason, banking practice, and the unanimous authority of five decisions passing directly on the point, two of them affirmed by the United States Supreme Court, to the effect that when a claimant in receivership is seeking to trace trust funds through a commingled account, merely showing the overnight balances of such account is not *prima facie* or any evidence of the "low balance" of such account. The claimant has the absolute burden of proving the actual "low balance" at all times remaining in the account, and that burden never shifts to the receiver, for to shift it would be to grant an *improper preference* under the guise of tracing trust funds. We appreciate that the failure of this Court to give effect to these decisions was due to the fact that most of them were not cited to the Court by counsel for Security-First National Bank of Los Angeles (herein referred to as the Richfield bond trustee), and to the further fact that counsel for the Richfield bond trustee did not emphasize those of the decisions which were cited.

3. It fails to recognize and apply the local rules of property established by the decisions of the Supreme Court of the State of California with respect to the prop-

erties which are the subject of these proceedings, all of which are either real or personal property situated in the State of California. The Supreme Court of the State of California has established the rule of property that as against creditors of an insolvent trustee *ex maleficio*, a *cestui* claimant has no property interest in a bank account of the trustee in which funds of the *cestui* and trustee have been commingled, once checks equal in amount to the *cestui's* funds deposited in the account have been charged against that account. It is respectfully but earnestly submitted that this rule of property is binding on the federal courts, and that under this rule and the facts established in this case, Universal had no property interest in the Richfield bank account at the time the several investments, which are the subject of this proceeding, were made, and consequently could not possibly have a property interest in the investments.

4. It is contrary to the weight of authority, the decisions of the United States Supreme Court, and the decisions in other circuits, in that it permits "tracing" of trust funds from a commingled account into investments made with checks against that account, without any evidence whatsoever that the trust funds were in fact appropriated to the investments. There is no requirement that the trust funds must be traced into the identical dollars deposited or that the trust funds can only be traced into money, but the overwhelming weight of authority is to the effect that to trace trust funds from a commingled account into an investment there must be evidence that the trust funds in the account were in fact appropriated to the particular investment into which it is sought to trace them.

I.

It Is Respectfully and Earnestly Submitted That the Decision of This Court Is in Error in Failing to Recognize and Apply the Basic Principles of Federal Equity Receivership Established by the United States Supreme Court and by the Circuit Courts of Appeal in Other Circuits, Which May Be Briefly Summed Up in the Phrase "Equality Is the Highest Equity".

While the discussion of this first point is divided for convenience into four parts, it will be obvious to the Court that the decisions cited in each of the four parts have a direct bearing one upon the other, and should be considered together. With this thought in view we will not burden the Court by repeating the citation of a case under each part to which it may be relevant.

(a) **The Primary Object of a Federal Equity Receivership Is to Prevent One Claimant Recovering at the Expense of the Others, and to Bring About a Pro Rata Distribution Between Claimants. As Between Claimants "Equality Is the Highest Equity."**

The Receiver holds no brief for, and in no wise champions, Richfield or its former officers. Richfield is defunct, its chief former officers are now or have been incarcerated, and the Receiver has done what he could to assist in bringing them to justice and in collecting for the creditors on their bonds. The Receiver is all too aware of the hardships which Richfield's acts and subsequent failure impose on Universal—and on each of the other some six thousand claimants against the estate. In certain instances the economic hardship caused by the Rich-

field receivership on claimants was so unbearable that the taking of their lives can be traced to the Richfield failure. Richfield was legally, equitably and morally bound to have repaid them *all* in full. Financial failure has made that impossible and the Federal Courts have appointed the Receiver as an officer of the Court to take over the assets of Richfield in order that there may be an equitable prorated distribution of the proceeds of those assets among all claimants, rather than the estate torn apart for the benefit of certain claimants at the expense of the rest.

An apparent exception to the rule of equality is that if a claimant can in fact establish that certain property held by the Court is the claimant's property and not part of the receivership at all, the Court will return his property to him. While the courts recognize that they would not be justified in dividing up among all claimants, as a part of the receivership estate, property in the hands of the receiver which one claimant was in fact able to prove was his own property, nevertheless it is equally well established that if any claimant to assets fails to absolutely identify and prove them as his own, as for example "where the means of ascertainment fail" or where evidence is such that the property may or may not be that of the claimant, the courts regard it as the highest equity to leave the property in the receivership estate for *pro rata* distribution to all claimants, including the claimant who seeks to trace, rather than take a chance on granting an unwarranted preference to one claimant at the expense of the rest. It is respectfully submitted that the decision of this Court in the above entitled cause is in error in holding that where, under the evidence, the property in question may or may not be that of the claimant who seeks to trace, and where, as here, the means of

ascertainment of the facts which would determine whether or not the property in question is that of the claimant have failed, the court should take the property out of the receivership estate and give it to one creditor at the expense of the others, even though the very purpose of the equity receivership was to insure a *pro rata* distribution and prevent preferences. As said by this Honorable Court in *Clark v. Bacorn* (C. C. A. 9, 1902), 116 Fed. 617-618:

“It is well settled that when a corporation becomes insolvent, and the corporate assets have passed into the hands of a receiver, such assets constitute a fund for ratable distribution among its creditors. * * *”
Clark v. Bacorn, 116 Fed. 617-618.

As stated in *Porter v. Boyd* (C. C. A. 3, 1909), 171 Fed. 305, 313:

“* * * the rule of equity requires the *pro rata* division of the assets among the creditors, subject to the allowance of costs and expenses and the adjustment and liquidation of priorities and preferences. *Equality* or a *pro rata* distribution of the assets among the creditors *being the most equitable result attainable*, no liens or preferences should be recognized *unless satisfactorily established*; and it is not only proper, but it is incumbent upon the receiver to protect the funds or assets in his hands against all attempts of creditors to defeat equality of distribution.” *Porter v. Boyd*, 171 Fed. 305, 313.

Among the some six thousand claimants who have presented their claims to the Federal Courts, relying on these courts to make an equitable *pro rata* distribution among them, are many whose claims are based on fraud equally

as reprehensible as that in the case of Universal, if not more so. This Court need only recall the judgment allowed by this Court in *United States v. Pan American Petroleum Company*, 55 Fed. (2) 753, for stolen oil from the Naval Petroleum Reserve, considerable portions of which oil were traced to Richfield from its subsidiary, Pan American Petroleum Company. This proceeding is not like a single issue between two rival claimants, for here allowing a preference to one will be at the expense of the rest, many of whom undoubtedly have claims even more appealing to the sympathy than Universal.

(b) There Is No Preference, Priority of "Equity" in Favor of Claimants Who Become Such by Reason of Fraud as Compared With Other Creditors.

In its opinion the Court expresses the thought that Universal has a greater "equity" than other creditors. If Universal had succeeded in tracing title to certain properties they would have established an equity or interest in those properties. But it is submitted that prior to establishing their title or interest in properties in the estate, Universal is entitled to no "equity", consideration, or preference over other claimants against the estate. To dispense with evidence proving title, or to resolve doubt as to the tracing of title in favor of Universal, or to shift the burden of proof of tracing to the Receiver, is merely to grant an improper preference under the guise of tracing. It is doing indirectly what the courts have repeatedly decided they would not do directly, to-wit, "allowing a *cestui* arbitrary preference because of the hardships and sympathies connected with his plight."

There are three types of claims in a receivership action such as that of Richfield: (a) general unsecured claims,

(b) preferred claims, (c) claims to a lien upon or title to specific items of property in the possession of the court. In those cases where a trust is raised by reason of conversion or misappropriation of funds, and the trustee *ex maleficio* becomes insolvent and a receiver is appointed, there is an equitable attachment of all of the property for prorated distribution to all creditors, including the defrauded *cestui* except to the extent that the *cestui* clearly identifies items of property in the receiver's hands as being the *cestui*'s property and therefore not part of the receivership estate at all. With respect to the status of the *cestui* as a claimant, both the Federal Courts and the courts of California have repeatedly considered the hardships upon and the sympathies for a *cestui* claimant and have firmly established the rule that such hardships and sympathies do not entitle the *cestui* claimant to any preference or consideration over other claimants to the insolvent estate. With respect to the *cestui* as a claimant of an identified trust *res*, his rights are property rights which he must establish by clear and unequivocal proof according to the rules for tracing titles.

Pottorff v. Key (C. C. A. 5, 1933), 67 Fed. (2) 833;

Texas & Pac. Ry. Co. v. Pottorff, Receiver (1934), 291 U. S. 245, 261;

Slater v. Oriental Mills (1893), 18 R. I. 352, 27 Atl. 443;

Wisdom v. Keen (C. C. A. 5, 1934), 69 Fed. (2) 349 (cited with approval in *Adams v. Champion*, (1935), 79 L. Ed. Adv. 366, 369);

Swan v. Children's Home Society of West Virginia (C. C. A. 4, 1933), 67 Fed. (2) 84, 88; Cert. denied, 290 U. S. 704, 78 L. Ed. 605;

Multnomah County v. Oregon Nat. Bank (C. C. Ore. 1894), 61 Fed. 912, 914;

In re Brunsing, Tolle & Postel (D. C. Cal. 1909), 169 Fed. 668, 669;

Lathrop v. Bampton (1866), 31 Cal. 17, 23-24;

Merchants & Farmers Bank v. Austin (C. C. Ala. 1891), 48 Fed. 25, 32;

Lucas County v. Jamison (C. C. Ia., 1908), 170 Fed. 338, 348-349;

Stilson v. First State Bank (1910 Ia.), 129 N. W. 70, 72-73;

1 *Bowles, Modern Law of Banking*, p. 190.

It is respectfully submitted that the decision in the instant case in this regard is at variance with the decisions of the United States Supreme Court, and with the decisions of the other circuit courts of appeal.

In *Pottorff v. Key* (C. C. A. 5 1933), 67 Fed. (2) 833, 834, the court said of a *cestui* who had failed to trace his money into the funds coming to the receiver's hand:

“Though the victim of a wrong and an involuntary creditor, *he has for that reason no better equitable right to what is in the receiver's hands than other creditors have.* The contrary view expressed in *San Diego County v. California Nat'l Bank* (C. C.), 52 F. 59, was disapproved in *Multnomah County v. Oregon Nat'l Bank* (C. C.), 61 F. 912, and *Spokane County v. First Nat'l Bank* (C. C. A.), 68 F. 979, and we believe *has not since been asserted in the federal courts.*” (Italics ours.) *Pottorff v. Key*, 67 Fed. (2) 833, 834.

In *Texas & Pac. Ry. Co. v. Pottorff, Receiver* (1934), 291 U. S. 245, 261, the United States Supreme Court said that a claim of unjust enrichment when a receiver sets aside a pledge as *ultra vires*

“does not, in the absence of an *identifiable res*¹⁹ and a constructive trust based on special circumstances of misconduct, confer a preference over other creditors.”

The Court's Note 19 on page 261 says:

“*The claimant has the burden of identifying the property in its original or altered form. Schuyler v. Littlefield, 232 U. S. 707, 58 L. Ed. 806, 34 S. Ct. 466 * * *.*” (Italics ours.) *Texas & Pacific Ry. Co. v. Pottorff, Receiver* (1934), 291 U. S. 245, 261.

The case of *Slater v. Oriental Mills*, 18 R. I. 352, 27 Atl. 443 (1893), used the following language which has been many times cited and approved by both Federal and State courts:

“Undoubtedly, it is right that everyone should have his own; but when a claimant's property cannot be found, this same principle prevents the taking of property which equitably belongs to creditors of the trustee to make it up. The creditors have done no wrongful act, and should not be called upon, in any way, to atone for the misconduct of their debtor. It is an ordinary case of misfortune on the part of claimants, whose confidence in a trustee or agent has been abused.” *Slater v. Oriental Mills*, 18 R. I. 352, 27 Atl. 443.

In *Swan v. Children's Home Society of West Virginia* (C. C. A. 4, 1933), 67 Fed. (2) 84, 88 (Cert. denied 290 U. S. 704, 78 L. Ed. 605), funds had been left to an

orphans' home and were left with a trustee bank, which failed. The Court denied a preference, saying:

“Those entitled to trust funds held by the bank may enforce the trust against the receiver, not on the ground that the law gives them a preferred status, but that the receiver has property which in equity and good conscience belongs to them. But, unless they can trace the trust funds into some fund or specific property which has come into his hands, or can show that the assets in his hands have been directly augmented as a result of the conversion of the trust funds by the bank, they have no basis upon which relief can be granted them. * * *

We can think of no nobler charity, nor of one making a stronger appeal to the human heart, than that of the plaintiff here, engaged as it is in providing for orphan and homeless children; and it is most unfortunate that funds intended for its use should have been lost. We have no option, however, but to declare the law as we find it.” *Swan v. Children's Home Soc. of West Virginia*, 67 Fed. (2) 84, 88.

In *Multnomah County v. Oregon Nat. Bank* (C. C. Ore. 1894), 61 Fed. 912, 914, the court said:

“The fact that the money of such creditor or *cestui que trust* cannot be traced to the fund sought to be charged is the reason that the preference is refused. * * * *His so-called right of preference, in other words, cannot in justice extend to the property of others. The theory of preference does not apply in these cases. There is no preference by reason of an unlawful conversion.* * * * When the means of ascertainment of the identity of property or proceeds fail, the right fails.” *Multnomah County v. Oregon Nat'l Bank*, 61 Fed. 912, 914.

1 *Bowles, Modern Law of Banking*, page 190, states:

“Many a beneficiary has been unable to recover, not through his failure to prove the existence of a trust, but of a fund that he could rightfully claim as his own.”

(c) **Against the Receiver and Other Creditors of an Insolvent Trustee, the Burden of Tracing Trust Funds Into the Hands of the Receiver Is Absolutely, Continuously and Unequivocally on the Cestui, and All Doubts and Possibilities Are Resolved in Favor of the Receiver, in Order That there May Be an Equitable, Pro Rata Distribution of the Entire Estate Among All Claimants, Including the Cestui.**

If the trust fund is not clearly identified at all times between its creation and the advent of receivership, as for instance in a case where the means of ascertainment fail for lack of records, the equitable principle of equality places the *cestui* on a parity with other creditors to share ratably in the whole receivership estate, including the properties sought to be traced. The whole reason for receiverships and the unanimous weight of authority in the decided cases require that all doubts as to identification be resolved against the claimant.

Schnuyler v. Littlefield (1914), 232 U. S. 707, 713, 58 L. Ed. 806, 809;

Texas & Pac. Ry. Co. v. Pottorff, Rec'r (1934), 291 U. S. 245, 261, 78 L. Ed. 777, 786, note 19;

Titlow v. McCormick (C. C. A. 9, 1916), 236 Fed. 209, 211;

In re J. M. Acheson Co. (C. C. A. 9, 1909), 170 Fed. 427;

Poole v. Elliott (C. C. A. 4, 1935), 76 Fed. (2) 772, 774;

In re A. D. Matthews' Sons, Inc. (C. C. A. 2, 1916), 238 Fed. 785, 786;

Cook v. Elliott (C. C. A. 4, 1934), 73 Fed. (2) 916, 918;

Harmer v. Rendleman (C. C. A. 4, 1933), 64 Fed. (2) 422, 423;

First Nat. Bk. of St. Petersburg v. City of Miami (C. C. A. 5, 1934), 69 Fed. (2) 346, 349;

Kershaw v. Jenkins (C. C. A. 10, 1934), 71 Fed. (2) 647, 649;

In re Bogena & Williams (C. C. A. 7, 1935), 76 Fed. (2) 950, 955.

The decision in the instant case in this regard is clearly at variance with prior decisions of the United States Supreme Court and with the decisions of the other Circuit Courts of Appeal.

In the case of *Schuyler v. Littlefield*, 232 U. S. 707, 713, 58 L. Ed. 806, 809 (1914), the court said:

“They were practically asserting title to \$9,600, said to have been traced into stock in the possession of the trustee. Like all other persons similarly situated, they were under the burden of proving their title. *If they were unable to carry the burden of identifying the fund as representing the proceeds of their interborough stock, their claim must fail. If their evidence left the matter of identification in doubt, the doubt must be resolved in favor of the trustee, who represents all of the creditors * * *, some of whom appear to have suffered in the same way. Like them, the appellant must be remitted to the general fund.*” (Italics ours.) *Schuyler v. Littlefield*, 232 U. S. 707, 713, 58 L. Ed. 806, 809.

In *Texas & Pac. Ry. Co. v. Pottorff, Receiver* (1934), 291 U. S. 245, 261, the court repeated its earlier decision that where a *cestui* seeks to trace a trust *res* into the hands of a receiver

“the claimant has the burden of identifying the property in its original or altered form.” *Texas & Pac. Ry. Co. v. Pottorff, Rec’r*, 291 U. S. 245, 261, note 19.

In *Titlow v. McCormick* (C. C. A. 9), 236 Fed. 209, 211, this Court, through Ross C. J., said:

“In *Schuyler v. Littlefield, Trustee of Brown & Co.*, 232 U. S. 707, 34 Sup. Ct. 466, 58 L. Ed. 806, it was *distinctly* adjudged by the Supreme Court that where one has deposited trust funds in his individual bank account, and the mingled fund is at any time wholly depleted, the trust fund is thereby dissipated, and cannot be treated as reappearing in sums subsequently deposited to the credit of the same account. It was in that case further *adjudged*, as it has been in many others, that one seeking to charge a fund in the hands of a trustee for the benefit of all creditors as being the proceeds of his property, and therefore a special trust fund for him, has the burden of proof, and if he is unable to identify the fund as representing the proceeds of his property, his claim must fail, *as all doubt must be resolved in favor of the trustee who represents all creditors.* This court also so held in the case of *In re J. M. Acheson Co.*, 170 Fed. 427, 95 C. C. A. 597.” (Italics ours.) *Titlow v. McCormick*, 236 Fed. 209, 211.

In his brief *amicus curiae* Mr. David R. Faries cites *In re J. M. Acheson Co.* (C. C. A. 9), 1909, 170 Fed. 427, as indicating that there is some burden of proof on the Receiver. (*Amicus curiae* brief, page 15.) The *Acheson*

case was decided before *Schuyler v. Littlefield*; it was construed by this Court in *Titlow v. McCormick, supra*, to hold that all doubts must be resolved in favor of the trustee in bankruptcy; and Mr. Faries quotes only an isolated portion of the opinion which the Court later expressly construes against Mr. Faries' contention. The *Acheson* case was disposed of entirely on a demurrer to the complainant's complaint seeking to trace trust funds. The Court commented upon the fact that the complaint alleged that trust funds were mingled with the trustee's own funds, and that the trustee then "used *the said trust funds* to pay its current running expenses, its creditors other than petitioner, and to buy merchandise, which merchandise composed the bankrupt's assets which passed into the hands of the Receiver of the Court and were sold by him".

As quoted by Mr. Faries, the court said:

"In carrying out the rule, when it comes to proof, *the owner must assume the burden of ascertaining and tracing the trust funds*, showing that the assets which have come *into the hands of the trustee* have been directly added to or benefited by an amount of money realized from the sales of the specific goods held in trust; and recovery is limited to the extent of this increase or benefit. *City Bank of Hopkinsville v. Blackmore*, 75 Fed. 771, 21 C. C. A. 514; *Cushman v. Goodwin*, 95 Me. 353, 50 Atl. 50. If, however, he succeeds in making requisite proof, it then devolves upon the bankrupt, or the trustee who takes the property of the bankrupt, in the same relation that it was held by the bankrupt, to distinguish between what is his and that of the *cestui que trust*. *Smith v. Mottley*, 150 Fed. 266, 80 C. C. A. 154;

Smith v. Township of Au Gres, 150 Fed. 257, 80 C. C. A. 145, 9 L. R. A. (N. S.) 876." *In re J. M. Achson Co.*, 170 Fed. 427, 429.

As Mr. Faries failed to quote, the court said:

"We do not mean to be understood as holding that equity will grant to a *cestui que trust* relief against any assets in the hands of a trustee, for it will not go farther than to give a lien *when the facts are* that there *remain in the estate* specific funds or property which have increased the assets of the estate, and which represent the proceeds of the specific property intrusted to the bankrupt. *Lowe v. Jones, Adm'r*, 192 Mass. 94, 78 N. E. 402, 6 L. R. A. (N. S.) 487, 116 Am. St. Rep. 225. Moreover, if there has been expenditure, and the funds are gone, and no specific property or money is found instead of the funds *it is inequitable that some other property found should be applied to pay one creditor in preference to another*. So, funds that have been dissipated or that have been used to pay other creditors or that have been spent to pay current business expenses are not recoverable, because they are gone and there is nothing remaining to be the subject of the trust. This qualification of the general rule is to be applied to the facts pleaded in the present case inasmuch as it is alleged that some of the trust moneys were used by the bankrupt in paying its employees, and in the expenses of running its business, and in paying other creditors. For them there can be no recovery. *Slater et al. v. Oriental Mills et al.*, 18 R. I. 352, 27 Atl. 443; *Nototuck Silk Co. v. Flanders*, 87 Wis. 237, 58 N. W. 383. But for the moneys represented by assets which went into the hands of the receiver under the circumstances alleged, and which the petition charges that the receiver had when claimants filed their petition,

there appears to be an equitable claim, to support which *petitioners should be allowed to introduce evidence.*" (Italics ours.) *In re J. M. Acheson Co.*, 170 Fed. 427, 430.

In the case of *In re A. D. Matthews' Sons, Inc.* (C. C. A. 2, 1916), 238 Fed. 785, 786 (approved in *S. L. & S. F. R. Co. v. Spiller*, 274 U. S. 304, 310), when a department store failed, one who had conducted a department under an agreement that funds from his department would be kept separate, endeavored to reclaim his funds. The Court held there was no tracing, saying:

"* * * the burden of proof was upon the fashion company to clearly trace the proceeds of said sales into 'some specific fund or property' in the hands of the trustee in bankruptcy (*In re McIntyre*, 185 Fed. 96, 108 C. C. A. 543; *In re Ennis*, 187 Fed. 728, 109 C. C. A. 476; *In re Brown*, 193 Fed. 24, 113 C. C. A. 348, affirmed as *Schuyler v. Littlefield*, 232 U. S. 707, 34 Sup. Ct. 466, 58 L. Ed. 806; *In re See*, 209 Fed. 174, 126 C. C. A. 120); and if petitioner did not succeed in carrying that burden of identification, *if the evidence left the matter in doubt, such doubt must be resolved in favor of the trustee.*" (Italics ours.) *In re A. D. Matthews' Sons, Inc.*, 238 Fed. 785, 786.

The decision in *Harmer v. Rendleman* (C. C. A. 4, 1933), 64 Fed. (2d) 422, 423, was by Judge Parker, who, as will later appear, decided a great number of trust fund tracing cases in West Virginia. The court said:

"The old rule with regard to the tracing of trust funds wrongfully misapplied, or the proceeds of property wrongfully converted, was that the right ceased

when the property was turned into money and mixed and confounded in the general mass of property of the same description. * * * The modern rule, however, is that where such property or its proceeds has gone to swell the aggregate in the possession of the fraudulent party, it may, under proper proceedings, be segregated in amount from such aggregate sum, and made the subject of a trust, in order to accomplish the ends of justice. * * *

But there is a limitation upon this modern rule as well settled as the rule itself, viz., that it is not sufficient to prove merely that the trust property has gone into the general estate and has presumably increased its amount and value. It is indispensable that clear proof be made that the trust property or its proceeds has gone into a specific fund, or into a specific identified piece of property, or has directly augmented a fund upon which the trust is to be declared. When it is sought to impress funds in the hands of a receiver with a trust on account of the wrongful conversion of trust property by an individual or corporation to whose rights he has succeeded, it must be shown that the funds in his hands have been directly augmented by the presence of the trust property or its proceeds, so that a court of equity can see with certainty that the trust property is in his hands." (Italics ours.) *Harmer v. Rendleman*, 64 Fed. (2) 422, 423.

In *First Nat. Bank of St. Petersburg v. City of Miami* (C. C. A. 5 1934), 69 Fed. (2) 346, 349, the court denied the claim of a *cestui* who sought to impress a trust on funds in the hands of a receiver, saying:

"* * * to obtain preferential treatment in the distribution of the assets of failed banks, one seeking

to charge the fund in the hands of the receiver for the benefit of all the creditors, as being his property or its proceeds, *has a heavy burden of proof*, and unless he clearly and certainly identifies the fund he must fail. *Schuyler v. Littlefield*, 232 U. S. 707, 34 S. Ct. 466, 58 L. Ed. 806. We do not understand anything decided in the Miami Bank Case, *supra*, contravenes these views. Any expression in it, which admits of a contrary construction, is expressly disapproved." (Italics ours.) *First Nat. Bk. of St. Petersburg v. City of Miami*, 69 Fed. (2) 346, 349.

In the case of *In re Bogena & Williams* (C. C. A. 7 1935), 76 Fed. (2) 950, 955, the court summed up the tendency in recent United States Supreme Court and Circuit Court of Appeals cases as follows:

"We do not wish to be understood as saying that the recent decisions have abrogated former positive rules of law with respect to trust funds, *but they have required stricter proof in the establishment of trust funds where general creditors are involved.*" (Italics ours.) *In re Bogena & Williams*, 76 Fed. (2) 950, 955.

We respectfully submit that the opinion of this Court is at variance with the foregoing decision of the United States Supreme Court and of the other Circuit Courts of Appeal in that it places the burden of proof *on the receiver* with respect to one of the essential facts necessary to the tracing of Universal's funds, a fact of which the means of ascertainment have now failed. The decision of this Court in effect dispenses with proof of tracing, for until the chain of evidence is completed there is no tracing at all. A "partial" tracing is in effect nothing more than an improper preference.

(d) The Receiver, Who Is an Officer of the Court, and the Other Creditors Who Have Done No Wrong to Universal Must Not Be Confused With the Insolvent Tort Feasor.

We respectfully submit that this Court was in error in assuming that Universal's claim in the receivership is to be regarded in the same light as had it been against the tortfeasor Richfield. In the opinion it is stated that it was admitted that the Receiver was a constructive trustee for Universal. Rather, the admission was that Richfield was the constructive trustee for Universal. The Receiver made no admission and expressly denies that any such trust relationship existed between himself and Universal. Again, it is stated later in the opinion, with respect to the dearth of evidence on the low balance, "Such liability as might have resulted therefrom should be borne by the tortfeasor, not the innocent *cestui*." It is submitted that the tortfeasor Richfield has no further interest in this matter. Any issue now is between the many claimants against the receivership estate, including Universal. We respectfully protest confusing the Receiver with the tortfeasor Richfield in these proceedings.

Harry E. Jones, Inc. v. Kemp (C. C. A. 9, 1935),
74 Fed. (2) 623, 627;

In re Byrne (C. C. A. 2, 1929), 32 Fed. (2) 189,
190;

Wisdom v. Kcen (C. C. A. 5, 1934), 69 Fed. (2)
349 (cited with approval in *Adams v. Champion*,
79 L. Ed. Adv. 366, 369);

Maryland Casualty Co. v. Williams (Ala., 1935),
159 So. 242, 244.

In the case of *Harry E. Jones, Inc. v. Kemp* (C. C. A. 9, 1935), 74 Fed. (2) 623, 627, the claimants of a trust against an insolvent estate asserted that the receiver was estopped to show that the bank accounts into which their funds went had been dissipated. The court denied this, saying:

“The contention that the receiver ‘stands in the same position that the Guaranty Building and Loan Association does,’ and therefore ‘is estopped to show the moneys received from Investors of America and H. E. Jones, Inc., is not on hand,’ is without merit. It is an admitted fact that the association was insolvent when the assets were taken over by the receiver. Under such circumstances the receiver is not only bound to consider rights of claimants as between such claimants and the insolvent corporation, but the respective rights of creditors as between themselves.”
Harry E. Jones, Inc. v. Kemp (C. C. A. 9, 1935), 74 Fed. (2) 623, 627.

In the case of *In re Byrne* (C. C. A. 2, 1929), 32 Fed. (2) 189, 190, claimants showed that certain securities were turned over to a broker which he was to hold in trust but instead converted. Upon the bankruptcy of such broker claimants seek a preference against the bankruptcy estate. This was denied, the court saying:

“The appellants have quite misapprehended their rights and have proceeded throughout on the assumption that they are entitled to the same relief in bankruptcy as they would have had against the bankrupts

in personam. Their claim is not that, but against the *res* administered in the bankruptcy court. To get any standing, except as general creditors, they must identify the original assets, or trace them into other specific funds which came into the trustee's hands. It is not enough to show that they were converted by the bankrupt, or indeed that they may have generally enriched their estate." *In re Byrne*, 32 Fed. (2) 189, 190.

In *Wisdom v. Keen* (C. C. A. 5, 1934), 69 Fed. (2) 349 (cited with approved in *Adams v. Champion*, 79 L. Ed. Adv. 366, 369, the court said:

"Equity if dealing with the bank alone might well consider that it had done what it should have done and might well hold it to the consequences. *American National Bank v. Miller*, 229 U. S. 517, 33 S. Ct. 883, 57 L. Ed. 1310. But in dealing with the distribution of the assets of an insolvent national bank and with the requirement of ratable dividends to all claimants a more stringent adherence to what was actually done is proper * * * as to every general creditor the bank has failed to do what it ought to have done and what it promised to do. The federal statute puts all such claimants on an equality." *Wisdom v. Keen*, 69 Fed. (2) 349, 350.

In *Maryland Casualty Co. v. Williams* (Ala., 1935), 159 So. 242, 244, the court, in denying a *cestui* recovery against an insolvent bank where the *res* had not been sufficiently traced, said:

“Equities against the bank, as such, and its stockholders, need not be considered. The assets of the bank have become a trust fund in which the equities of creditors are to be worked out.” *Maryland Casualty Co. v. Williams*, 159 So. 242, 244.

There is only one situation in which the receiver has any burden of proof whatsoever. That arises under the following circumstances: In the majority of the Federal decisions the so-called low balance theory is approved, *i.e.*, that *after* the *cestui* has proved that his funds went into a commingled account and *after* the *cestui* has proved that the balance in said account contained *at all times* between the deposit and the receivership a balance greater than the amount of the trust fund deposit, and *after* the *cestui* has proved that there came into the hands of the receiver from such account a sum greater than the amount of the trust deposit, it will be presumed that the amount coming to the hands of the receiver from the account included the amount of the trust deposit. The courts, however, clearly state that this is a rebuttable presumption which will not stand against evidence to the contrary and that the receiver may adduce evidence to the effect that the trust moneys were actually earmarked and dissipated and thereby overcome the presumption that they remained in the low balance. See *Board of Commissioners v. Straven*, 157 Fed. 49.

Mr. David R. Faries, in his Brief *Amicus Curiae*, in this proceeding, cites the language from five cases to the

effect that the burden of proof in tracing trust funds is on the receiver:

Meyers v. Baylor University (Texas Civil Appeals), 6 S. W. (2) 393;

Grand Forks County v. Baird, 54 N. Dak. 315, 209 N. W. 782;

Farmers' Bank v. Bailey, 221 Ky. 55, 297 S. W. 938;

Hawaiian Pineapple Co. v. Browne, 69 Mont. 140, 220 Pac. 1114;

Israel v. Woodruff (C. C. A. 2, 1924), 299 Fed. 454, 457.

The first of these five cases, *Meyers v. Baylor University*, *supra*, was not even an insolvency case, but was merely against the tortfeasor trustee. Under such circumstances the courts feel no restraint in penalizing the trustee with as many presumptions and inferences as they can imagine.

The last of these five cases, *Israel v. Woodruff*, *supra*, was a case where the trustee had paid the *cestui* in full before his bankruptcy, and the trustee's receiver was endeavoring to recover the payment as an improper preference. Under the facts of the case there was practically an appropriation to the trust and the court said that to recover the funds the receiver had the burden of proving that they were not trust funds. Obviously a decision on such facts is not relevant to the Universal claim.

Finally, the first four of the said five cases are minority state cases, enunciating the oft repudiated principle that if

a claimant introduces evidence as to the amount of his trust funds and then merely shows that the receiver took over at least that amount among the assets of the insolvent, it will thereupon be presumed that the trust funds were included in the amount taken over by the receiver, without any showing whatsoever as to what happened to the funds between the time the trust arose and the date of the receivership. These four cases represent a principle which has been expressly and conclusively repudiated countless times by both the federal courts and the Supreme Court of California, as appears from the authorities cited in Point II (a) immediately following.

It is respectfully submitted that under the authority of the decisions of the United States Supreme Court and other circuit courts of appeal, cited in the four parts of this first point, it is established that the primary purpose of an equity receivership is to divide *pro rata* among all claimants the insolvent estate which is not sufficient to pay all of them in full as they had a right to be paid; that the fact that some of the claims arise out of fraud does not entitle such claimants to any preference, consideration, or "equity" over other claimants; that the federal courts will jealously guard equality of distribution as the highest equity, will only permit such equity to be disturbed by a clear proof that certain of the property in the custody of the court does not belong in the receivership estate at all, and will resolve all doubts and possibilities in favor of the receiver; and finally that such matters as sympathies and hardships must not be substituted for evidence, because the receiver and the creditor are not the *tortfeasor* who gave rise to such hardships and sympathies.

II.

It Is Respectfully Submitted That It Is Established by the Decisions Requiring the Cestui to Prove the "Low Balance" (Part (a) Below), by Reason and Banking Practice (Part (b) Below), and by the Unanimous Authority of Five Decisions Passing Directly on the Point, Two of Them Affirmed by the United States Supreme Court (Part (c) Below). That When a Claimant in Receivership Is Seeking to Trace Trust Funds Through a Commingled Account, Merely Showing the Overnight Balances of Such Account Is Not Prima Facie or Any Evidence of the "Low Balance" of Such Account. The Claimant Has the Absolute Burden of Proving the Actual "Low Balance" at All Times in the Account, and That Burden Never Shifts to the Receiver, for to Shift It Would Be to Grant an Improper Preference Under the Guise of Tracing Trust Funds.

- (a) When the Low Balance Theory of Tracing Is Applied to an Account in Which Trust Funds and Other Funds Are Commingled, the Burden Is on the Cestui to Prove the Actual Low Balance Continuing in the Account at All Times Between the Time the Trust Funds Were Commingled in the Account and the Time to Which the Cestui Is Seeking to Trace Such Funds.

Blumenfeld v. Union Nat. Bank (C. C. A. 10, 1930), 38 Fed. (2) 455;

Kershaw v. Jenkins (C. C. A. 10, 1934), 71 Fed. (2) 647, 649;

Borman et al. v. Sullivan (C. C. A. 7, 1935), 77 Fed. (2) 342, 344;

In re Bogena & Williams (C. C. A. 7, 1935), 76 Fed. (2) 950, 953-4;

In re Mulligan (D. C. Mass. 1902), 116 Fed. 715;

Orcutt v. Gould (1897), 117 Cal. 315 (1897).

In *Blumenfeld v. Union Nat. Bank* (C. C. A. 10, 1930), 38 Fed. (2) 455, 456, the court said:

“In the instant case there is a dearth of evidence to show what amount of money remained in the Beloit bank through the period dating from the time it acquired the trust fund on July 28, 1922, to the date the receiver took charge on November 5, 1923. In the meantime, all its moneys, together with the trust fund, may have been disbursed. *The authorities cited establish that it is insufficient to trace the fund into the bank and to show that its cash or equivalent on its failure exceeded appellant's claim. If a trust fund is wholly depleted at any time, it cannot be treated as reappearing in subsequent accumulations, and a claimant of a trust fund has the burden of identifying it. Schuyler v. Littlefield, 232 U. S. 707, 34 S. Ct. 466, 58 L. Ed. 806; In re Brown (C. C. A. 193 Fed. 24).*

The appellant wholly failed to meet this burden of proof, and, the fund standing unidentified, he was not entitled to recover it preferentially from the receiver.” (Italics ours.) *Blumenfeld v. Union Nat. Bank*, 38 Fed. (2) 455, 456-7.

In *Kershaw v. Jenkins* (C. C. A. 10, 1934), 71 Fed. (2) 647, 649, the court said:

“One seeking to impress a trust upon the assets of an insolvent national bank in the hands of a receiver must establish a fiduciary relationship between him-

self and the bank in connection with the transaction giving rise to the claim, and he must trace the trust fund or property in its original or converted form into specific or identifiable property in the possession of the receiver. The trust *res* may be traced for that purpose *by proof clearly showing* that the assets of the bank were augmented through the transaction, *and, further, that the augmented fund was not depleted* intermediate the transaction and insolvency of the bank to a sum less than the amount of the claim. *Proof that the augmented fund was not so depleted is required* because a trust does not survive depletion and attach itself to subsequent accumulations. The equity of such a claim depends upon the effect the money or property of the *cestui que trust* had in swelling the assets *in the hands of the receiver*. * * * But, *if the proof fails to establish these essential elements*, full payment of the claim from money in the hands of the *receiver* for ratable distribution among *creditors* would be inequitable." (Italics ours.) *Kershaw v. Jenkins*, 71 Fed. (2) 647, 649.

In *Borman et al. v. Sullivan* (C. C. A. 7, 1935), 77 Fed. (2) 342, claimant requested her bank to buy certain bonds and gave it a check on the same bank for the purchase price on June 18, 1932. On June 20th the account of claimant was charged with the check and on June 21st a cashier's check was sent to the seller of the bonds by the bank, whereupon the bank picked up the bonds. On June 22, 1932, the bank closed and a receiver was appointed. The cashier's check was not honored and the seller of the bonds was permitted restitution thereof by the receiver. It was stipulated that the receiver took

over more in cash than the amount claimed as a trust fund by claimant. The court denied a tracing, saying:

“Conceding without admitting that the bank’s assets were augmented by the transaction, and that there was a trust created, yet we think appellants’ contention must fail because no part of the so-called trust fund was traced into the hands of the receiver. The mingled funds were not ear-marked, and if the tracing of those funds into the receiver’s hands is to be established it must be by virtue of the fact that at all times since the bank received the money in trust, it had enough currency on hand to equal the amount of the trust fund which it is claimed the receiver received. Appellants’ check was delivered to the bank on June 18, 1932. It was not charged to appellants’ account in the bank until June 20, 1932, and the bank was not closed until June 22, 1932. The stipulation is that when the bank was closed it had in its possession more than \$2,065.98 in currency, which was paid to the receiver. The record does not disclose the status of the bank’s currency account at any time between the time at which it is claimed the bank received the money in trust and the time it closed. The court can not indulge in the presumption that during that time the currency account remained sufficient to cover the claim or any part of it. *However short the intervening time, it was possible that the currency account was depleted and replenished*, and if it were once depleted there could be no tracing under the theory we are now discussing. St. Louis & S. F. R. R. v. Spiller, 274 U. S. 304, 47 S. Ct. 635, 71 L. Ed. 1060.” (Italics ours.) *Borman et al. v. Sullivan*, 77 Fed. (2) 342, 344.

(b) From the Standpoint of Banking Practice and Reason, the Overnight Balances of a Bank Account Are Neither Prima Facie Evidence, Nor in Fact, Any Evidence at All That the Balance in the Account Did Not Fall Below the Closing Balance at Some Time During the Preceding Day, Especially Where the Amount of Checks and Deposits Entering Into the Account Each Day Is in Evidence.

There were three schedules introduced before the Master with respect to the bank account in which the Richfield funds were deposited: (1) the closing overnight balances shown on the bank's record for each day, (2) the intermediate balances entered on the bank's books during the course of each day, and (3) the total amount of checks and the total amount of deposits shown on the bank's books with respect to said account for each day.

The first of these was prepared by the Receiver and claimant and introduced by the claimant; the second of these was, at the request of the claimant, prepared and presented by the Receiver; and the third was prepared and presented by the Receiver in order that the Master, the courts and all the parties could have the advantage of all of the facts available. It was and is the opinion of the Receiver that the claimant had proved nothing without the introduction of this third schedule, even if successful on all of its legal contentions, and it has constantly been the policy of the Receiver, as an officer of the court, to make available at the hearings on claims all evidence within his power to produce, not only that against but that in favor of a claimant.

As to the so-called intermediate daily balances, the officers of the bank, the Special Master, the trial court,

this Honorable Court and every party to the action, including Universal and the Receiver, have repudiated these intermediate figures as not having any probative value in showing the low balance of the account, so we need not discuss these further.

As to the overnight balances taken alone, these have no more probative effect on the low balances in the account than the intermediate balances. The overnight balances do show the balances in the account for that *part* of the time *outside of business hours* when the account is *inactive*, but they show nothing whatsoever as to the low balance in the account *during business hours* when the account is *active*. It is respectfully submitted that this Honorable Court is in error when it states that the overnight balances only are accepted and used by both the bank and the customer in ordinary business transactions. True, these are the only balances of which the bank maintains a permanent record *after the day's business is concluded*. But from hour to hour and minute to minute throughout the day the bank recognizes changes in the account and, for example, would only certify checks against the true balance of the account at the minute when the check is presented for certification, regardless of what the opening or closing balance for the day might be. The court really affirms this practice when it says of the checks and deposits, "They react upon one another in rapid succession," or, in other words, that the balance in the account moves up and down rapidly throughout the business day.

It is submitted that the following is the true explanation of the bank's practice. The bank by accepting deposits from Richfield becomes the debtor of Richfield to

the extent of the deposits on an open book account. The fact that Richfield may have been trustee for Universal does not change the relationship between Richfield and the bank from that of a debtor and creditor relationship. The United States Supreme Court has so held even in the case of the trust funds deposited with the bank and known by the bank to be trust funds, saying, in *National Bank v. Insurance Company* (1881), 104 U. S. 54, 63, 64, 66:

“A bank account, it is true, even when it is a trust fund, and designated as such by being kept in the name of the depositor *as trustee*, differs from other trust funds which are permanently invested in the name of the trustees for the sake of being held as such; for a bank account is made to be checked against, and represents a series of current transactions.”

“But although the relation between the bank and its depositor is that merely of *debtor and creditor*, and the balance due on the account is only a debt, yet the question is always open, To whom in equity does it beneficially belong?”

National Bank v. Insurance Company, 104 U. S. 54, 63, 64, 66.

The bank held no cash of Richfield or of Universal, but was merely indebted to Richfield on an open book account, and Universal claimed an interest in that account. When the bank cashed, or accepted from the clearing house, a check drawn by Richfield, the bank, to that extent, discharged its indebtedness to Richfield and thereby reduced the account, whether or not the checks had yet been posted by the machines on the ledgers. The account was merely a chose in action which at any moment of time had no

existence other than in the then net balance of the debits and credits. Could it be contended for a minute that if the ledgers showed a balance of \$100,000.00 on Richfield's account at 10:30 A. M. on January 15, 1931, the time of the inception of Richfield's receivership, and the bank had that morning cashed at its counters checks drawn on it by Richfield for \$50,000.00, none of which checks had been posted, that the account between Richfield and the bank was still \$100,000.00?

It was testified by the chief clerk of the bank that if a check was presented for payment or certification at any time during the day, the teller would look not only to the posted balance but also to the unposted items to ascertain the balance in the account. Thus, at any given moment of time the bank could ascertain the accurate balance of the account, although years later those conditions cannot be reconstructed. In order to assist the claimant should the Master determine all other issues in its favor, the Receiver put in evidence the only relevant evidence existing at the time as to the amount below which the balance in the account did not go, a schedule of the total of checks and the total of deposits entering into the account each day. Beyond this the means of ascertainment fail and as said in innumerable cases "when the means of ascertainment fail, the trust wholly fails, and the party can only prove as a general creditor."

Burnham v. Barth (Wis., 1895), 62 N. W. 96, 98;
Multnomah County v. Oregon Nat. Bank (C. C. Ore., 1894), 61 Fed. 912, 914.

To have the overnight balances evidentiary of the low balances in the account, it would be necessary to assume (1) that the *first* transaction *every* day was a deposit (for if it were a check the account would immediately and inevitably fall below the previous overnight balance); (2) that *throughout the day* deposits were made prior to the presentment of a corresponding amount of checks (for if the checks presented up to any given time during the day exceeded in amount the deposits made to that time, the account would necessarily fall below the last previous overnight balance); and (3) that the *last* transaction *every* day was a check (for if it was a deposit it would immediately be apparent that the account had been below the closing balance for the day). It is respectfully submitted that any such series of assumptions is wholly unsupported by evidence, reason or authority. Even the probabilities of the case overwhelmingly militate against any such assumptions. It is a well known fact of banking practice that the first batch of checks presented from the clearing house are presented in the morning *before* the bank opens its doors to depositors for the transaction of business and the making of deposits. This Honorable Court is well aware of this banking practice for it refers in its opinion to checks from the clearing house being presented at 8:15 A.M. Consequently, in an account as active as Richfield's, it would be practically impossible for the first transaction in the account each day, or for that matter any day, to be a deposit. Conversely, it is almost a certainty that the initial transaction in the account each day was a check necessarily drawing down the account

from the last previous overnight balance. Again, it is a frequent business practice to deposit the receipts for the day towards the closing of the banking day.

This account was the principal Richfield account covering many hundreds and even thousands of transactions a day. The members of this Court will know of their own experience that on the days when opening and closing balances in an account are highest the balance of the account in the middle of the day may be lowest. In an individual's account, if the only evidence given was the balance on January 1, 1930, and the balance on January 1, 1931, no one would contend that these balances indicated that the account never fell below the opening balance even though checks and deposits in amounts many times such balances went through the account during the year and there was no evidence of the order of such checks and deposits. The main bank account of Richfield which had over \$84,000,000.00 of deposits made in it and over \$84,000,000.00 of checks cashed against it during the period in which Universal seeks to trace its funds would probably have more transactions on a single day than the individual's account had during a whole year. The overnight balances of such an account could not possibly be any better evidence of the low balance in the account than the end of the year balances in the individual's account.

Coming now to the method used by the Special Master and the trial court in determining the amount which Universal had traced into the commingled account at the time

each investment was made therefrom, let us first hasten to say that there never has been a contention that the method used by the Master and the trial court established the actual low "balance" of the account. The method used does show, and it is respectfully submitted is the only evidence showing, the amount below which such low balance did not go.

At the hearing before the Special Master, a typical statement rendered to Richfield by the bank for November 22, 1929, showing an opening balance, numerous checks and deposits, several intermediate "balances" and a closing balance, was handed to witness McConnell, chief clerk of the bank, and the following questions were propounded and answers given:

"Q. I have here a statement rendered to Richfield Oil Company by the Security Bank. The ones I am calling your attention to are the entries for November 22, 1929. If you were asked what was the maximum amount which that statement evidences remained in the account during the whole day, how would you ascertain that? A. The maximum amount—

Q. Which remained in the bank account the whole day. A. The only way I could do that is by checking this balance ending November 21st, adding all these debits to the account, checks which have been charged, and subtracting it from them, and ignoring the credits entirely, is the only way I could give you an answer to that.

Q. Is that any evidence that the account might not have fallen below that amount which you mentioned, to-wit; the opening balance, less all the checks? A. It couldn't fall below that balance.

Q. Is there any evidence that it remained above that? A. No, there is no evidence whatsoever.

Q. By Mr. Weil: On your assumption, you would have to assume that you started in with the balance of the day before, and that all the checks came in before there were any deposits, and that is what you did—you would just assume there were no deposits, and you would deduct that from the opening balance of the day? In other words, you would play safe? A. That is it exactly. I would do that instead of assuming that some of the deposits came in before the checks did.”

It is respectfully submitted that if claimant had merely shown the overnight balances he would have adduced no evidence of low balance whatsoever. To the extent of the opening balance less all checks presented during the succeeding day, or conversely stated, the amount of the closing balance less all deposits made during the preceding day, the claimant could establish that the low balance, whatever it was in fact, was not below the figure thus arrived at. No other evidence introduced even indicated, let alone proved, that the low balance in the account was a greater amount. This method is not the use of a method of false accounting which takes into consideration checks and ignores equally important deposits. Rather, it is based on the legal and equitable rule that since the order of the checks and deposits is material to claimant's tracing, he must establish that order by proof or be limited to the amount which the evidence proved remained in the account. The deposits are not ignored. Rather, in the absence of proof as to the order of checks and deposits during any one day, the court is not warranted in assuming that any deposit was made before the presentation of the checks.

- (c) It Is Respectfully and Earnestly Submitted That Not Only Does Banking Practice, Reason and Common Sense Require That the Overnight Balances Be Not Taken to Fix the Low Balances in the Account When the Amount of Checks and Deposits Each Day Are Known and in Evidence, But That Unanimous Weight of Authority Requires That in Tracing Trust Funds Against an Insolvent Estate Overnight Balances of a Bank Account Be Not Accepted as Prima Facie or Any Evidence of the Low Balance of the Account During the Active Daytime Periods Intervening.

Marshburn v. Williams (D. C., E. D., N. C., 1926), 15 Fed. (2) 589, 590. (Opinion by Circuit Judge Parker of the Circuit Court of Appeals, 4th Circuit);

Nixon State Bank v. First State Bank of Bridgeport (Ala. 1912. Rehearing denied 1913), 60 So. 868, 869-870;

Ex Parte First Nat. Bank of Princeton In re A. O. Brown & Co. (D. C., S. D., N. Y., 1911), 189 Fed. 432, 437-439; affirmed under name *In re Brown* (C. C. A. 2, 1912), 193 Fed. 24; affirmed under name *First Nat. Bk. of Princeton v. Littlefield* (1912), 226 U. S. 110;

Ex Parte Schuyler, Chadwick & Burnham In re A. O. Brown & Co. (D. C., S. D., N. Y., 1911), 189 Fed. 432, 433-435; reversed under name *In re A. O. Brown & Co.* (C. C. A. 2, 1912), 193 Fed. 30; reversal by C. C. A. affirmed under name *Schuyler v. Littlefield* (1914), 232 U. S. 707, 58 L. Ed. 806;

Connolly v. Lang (C. C. A. 7, 1933), 68 Fed. (2) 199, 201-202.

See:

Borman et al. v. Sullivan (C. C. A. 7, 1935), 77
Fed. (2) 342, 344.

It is submitted that the decision in this case is at variance with and diametrically opposed to the above cited decisions of the United States Supreme Court and the decisions in the Second, Fourth and Seventh Circuits.

In *Marshburn v. Williams* (D. C., E. D., N. C. 1926), 15 Fed. (2) 589, 590 (opinion by Circuit Judge Parker), a claimant sought to recover the proceeds of certain bonds amounting to \$3,122.24 which it claimed were converted by the insolvent bank and that a trust was thereby raised. The proceeds were shown to have been deposited in an account of the insolvent with the American National Bank on December 15, 1922. On December 18, 1922, the insolvent drew checks on said account for \$2,500.00 and \$500.00 and deposited the same respectively to its account with the District National Bank of Washington and to its account with the Coal & Iron National Bank of New York. Shortly afterwards a receiver was appointed for the insolvent and the receiver took over balances of the insolvent from both the District National Bank and the Coal & Iron National Bank. Claimant asserted that it could trace its proceeds deposited in the account on December 15, 1922, into the deposits made from that account in the other two banks on December 18, 1922. Evidence of the overnight balances, the total amount of the checks and the total amount of the deposits on the days in question was presented to the court as follows:

	Opening Bal.	Checks	Deposits
Dec. 15	4608.38	27,000.00	24,275.74
Dec. 16	1884.32	16,946.80	23,241.31
Dec. 17	Holiday		
Dec. 18	8178.85	39,101.75	15,777.43

On this evidence the court held that because of the amount and number of checks against the account with the American National Bank between December 15 and December 18, claimant had not shown that any of the trust funds remained in the account on the latter date and that therefore none of the trust funds were included in the checks on this account deposited with the District National Bank and the Coal & Iron National Bank, saying:

“Complainant claims a balance of \$887.94 in the District National Bank of Washington, because on December 18th the Commercial drew a check on its account in the American for \$2500 in favor of that bank. Complainant likewise claims \$500 of a balance of \$845.05 in the Coal & Iron National Bank of New York, because on December 18th \$500 was transferred by the Commercial to the Coal & Iron National from the American. But an examination of the account with the American, which has been filed with the record, shows that these deposits in the District National of Washington and the Coal & Iron National of New York cannot be said in any sense to be the proceeds of the bonds in controversy. The Commercial had an Active Running Account With the American, which showed each day debits and credits of large amounts. On December 15th, the day when the bonds were debited against the American, the account was debited with another item of \$21,153.50. The balance from the preceding day was \$4,608.38. On the 15th the Commercial drew checks against the account for \$7,000, \$5,000, and \$15,000, respectively

leaving a balance, as stated above, of only \$1,884.32. On the 16th, the account of the American was debited with items of \$22,091.28 and \$1,150.03, against which there were withdrawals of \$16,520.29, \$210.67, \$114.34, and \$101.50, leaving a balance of \$8,178.85. On the next business day, the 18th, the account was debited with items of \$2.10, \$2,254.78, \$378.44, \$1,558.80, and \$11,583.31, against which there were withdrawals of \$10,000, \$10,000, \$15,000, \$1,000, and \$101.75, in addition to the \$2,500 to the District National and the \$500 to the Coal & Iron National, leaving an overdraft, as above stated, of \$15,145.47.

“This being the state of the account of the Commercial with the American between the time of the forwarding of the bonds and the sending of the checks to the District National and the Coal & Iron National, it is perfectly clear to my mind that complainant has not traced into the moneys sent to the District National and the Coal & Iron National the proceeds of the bonds in controversy or any part thereof, but that, on the contrary, it is shown that the proceeds of the bonds were inextricably intermingled with other assets of the bank.”

Marshburn v. Williams, 15 Fed. (2) 589, 590.

Similar facts to those in the foregoing case are presented innumerable times in the Richfield account. For instance, the facts for the period between December 23, 1929, and December 27, 1929, are as follows:

	Opening Bal.	Checks	Deposits
Dec. 23	949,358.12	848,223.61	417,606.58
Dec. 24	518,741.09	594,773.93	744,367.08
Dec. 25	Holiday		
Dec. 26	668,334.24	339,778.49	193,252.09
Dec. 27	521,807.84	516,584.02	319,830.72

It is respectfully submitted that this Court should have held that there was no evidence that the account was not overdrawn on December 24, 1929, and that this Court erred in looking at merely the overnight balances and finding that there were trust funds in the opening balance December 23rd which remained in the account and entered into investments made out of the account after December 27, 1929.

In *Nixon State Bank v. First State Bank of Bridgeport* (Ala. 1912—rehearing denied 1913), 60 So. 868, 869-870, the Nixon State Bank (Texas) sent a note for \$820 to the First State Bank (Ala.) for collection. The First State Bank collected by check of Wrenne & Co. and sent the latter check to the First National Bank (Nashville, Tenn.) for collection. The check was collected and the First National Bank placed in to the credit of the First State Bank in the account between them on May 14, 1910. On May 28, 1910, the First State Bank went into the hands of a receiver and the First National Bank turned over to said receiver the balance of the account amounting to \$1,193.61. The Nixon State Bank claimed \$820 as a trust fund but this was denied, the court saying:

“From May 13th to May 21st, both inclusive, the First State Bank remitted to the First National Bank of Nashville collections aggregating, daily, \$1,012.73, \$323.16, \$763.95, \$363.89, \$163.75, \$1,066.77, \$259.-37, and \$114.60. The daily *balances* with the First National Bank to the credit of the First State Bank, from May 14th to May 28th, both inclusive, varied between \$375.40, the lowest, and \$1,653.64, the highest; the balance on the last day being the said sum paid over by the First National to the receiver of the First State Bank. * * *

“The state of the account, and the varied, daily changes in its balances, between the insolvent bank and the First National Bank rendered it impossible that the proceeds, if such was the result, of the Talley note could be traced or identified with the precision necessary in order to impress it with a trust character, which equity, upon proper occasion, imposes to preserve, protect, and enforce the right of a principal whose property has been converted by the agent. It cannot be here held, as it was not in the decision mentioned, that the fund so received by the receiver was composed, in whole or in part, of the product of the payment of the Talley note. Indeed, the net daily balances between the insolvent bank and the First National Bank, subsequent to May 14, 1910, aggregate many thousands of dollars—a shifting, varying matter of daily credit and debit in the process of the daily adjusting of the account between them. The sum delivered to the receiver may as well have been the creation of credits sent, above debits made, to the First National by the insolvent bank on any day *after*, say, May 18th.

“The suggestion that the lowest balance with the First National Bank existing after May 14th, which was \$375.00, on May 16th, should be taken as composed of a part of the Wrenne & Co. check, upon which the Talley note was surrendered, cannot be adopted otherwise than arbitrarily. The gist of the pertinent doctrine of the Florence Bank decision is that, where funds or property of the principal are commingled by the agent with his property or funds, equity cannot effect its just purpose to impress the fund or property with a trust character, for the benefit of the principal, unless the principal’s funds or property can be distinguished—can be distinctly traced.

The considerations stated prevent the application of the doctrine, for that the funds, if so, of the petitioning bank cannot be distinguished.”

Nixon State Bank v. First State Bank of Bridgeport, 60 So. 868, 869-870.

The opinion in *Ex Parte First Nat. Bank of Princeton In re A. O. Brown & Co.* (D. C., S. D., N. Y., 1911), 189 Fed. 432, 437-439, was written by Judge Hand, who had previously written the opinion *Primeau v. Granfield* (D. C., N. Y. 1911), 184 Fed. 480, relied upon by claimant. The claim of First National Bank of Princeton and several others *were treated as one*, since all sought to make their claims good through the account of the bankrupt in the Hanover Bank. Consequently, conflicting claims of different *cestuis* were eliminated. All of the trust funds of these parties had gone into the Hanover Bank before August 24th with one exception. The court said:

“On the morning of August 24th that account contained over \$130,000, and they had a lien on *it*, for what money of theirs had gone into *it*, under *Knatchbull v. Hallett, supra*. On the morning of the 25th the account contained about \$6,200, which was at once entirely withdrawn and the account reduced to nothing. * * * The claims here must therefore depend upon the transactions of the 24th. On that day over \$3,700,000 was deposited in the account, and over \$3,800,000 was withdrawn.” (Italics ours.)

Ex Parte First Nat. Bank of Princeton In re A. O. Brown & Co., 189 Fed. 432, 437-439.

The various theories of claimants that they could claim securities bought with checks on said account on the 24th, and that they could claim collateral released by the payment of a designated secured loan of \$200,000, which payment and release of collateral was made with a check on said account on the 24th, are reviewed by the court, which then says:

“There is, however, no theory which does not involve the hypothesis that *up to the time of the supposed investment in the stocks in question the fund had remained continuously equal to the amount of the claims*. For example although the claimants were all entitled to a lien to the amount of their claims upon the account at the opening of business on the 24th, *yet if that account had been at any time that day reduced below that amount*, subsequent deposits would not restore to the claimants their rights. There is no presumption of an intent to restore, and in the case at bar it would be an obvious fiction. Now on the 24th the transactions were enormous. Only a part of the stock purchased was of the kind pledged upon these four loans. Indeed there were *drawn* over \$400,000 of checks for other purposes before any check was drawn to pay for any stocks of the kind placed with the loans. It is true that the order of drawing the checks is in no sense the same as the order of presenting them, but the fact mentioned at least shows the *possibility*. *The claimants therefore failed to prove that at the time of the alleged investments any of their money remained in the account, and that is a necessary step in tracing their money into any particular part of the estate.*” (Italics ours.)

In re A. C. Brown & Co., 189 Fed. 432, 438.

It should be noticed that when considering the proof, the court points out only the amount of checks drawn, and makes no mention of the deposits, for there was no evidence of their order. The court goes on to say that *cestui* must prove the amount in the account *at all times* during the day, saying it will not be presumed that the opening balance remained.

“Nor is there any presumption in the case that the fund always remained large enough to answer the trust moneys. The very first check *drawn* was greater than the opening balance and *it is the merest speculation to assume what were the deposits or what the amount in the bank's account all day long*. While equity will follow funds as long as they can be traced, it always requires affirmative proof by the beneficiary that his money went into some specific thing. Here, that proof would require *the claimants at least to show that at the time of each investment which they claim their money was in the bank—I mean at least that much money*. The same reasoning applies as to the payment of the \$200,000 note. * * *

“I need not therefore consider whether, for the purpose of establishing a lien, the beneficiary may select any earlier withdrawal which went into an investment and which has been preserved. If the general mixed fund has been wholly dissipated, it has been held that he may do so (*Re Oatway*, 1903, 2 Ch. Div. 356), and that *Knatchbull v. Hallett*, *supra*, does not limit him to a line only where the result will be to prevent his following his money. That presupposes what has not been shown in this case; that is, that the supposed investment was in fact made from a mixed fund. *The claimants have throughout assumed that throughout the 24th the fund remained large*

enough to cover their claims, and it is upon that rock that, in my judgment, their theory is wrecked." (Italics ours.)

In re A. C. Brown & Co., 189 Fed. 432, 438, 439.

There is no equivocation in this holding by Judge Hand made later than and referring to his decision in *Primeau v. Granfield*. There is no room for distinguishing the case on the ground that the account was overdrawn on the 25th, for his decision is with respect to investments made on the 24th. There is no room for distinguishing the case on the ground that the investments were not clearly pointed out and traced, for at least with respect to loan paid off, the particular investment was pointed out, proven and the collateral entirely traceable. The court based its decision on the ground that there was no tracing of the trust funds *into the account* immediately prior to the making of the *investment*. He refused to accept the opening balance for the day as evidence of the amount remaining in the account during the day at least when there was evidence as to the amount of checks and deposits entered on the account during the day but no evidence as to their order.

In the *Richfield* case a similar instance is found on February 25, 1930. On that day the opening balance was \$296,779.62. The amount of checks charged against the account was \$425,191.72, the amount of deposits in the account \$381,172.34 and the closing balance \$252,760.24. This Honorable Court, contrary to the finding of the special master, contrary to the finding of the trial court, and contrary to the authority of the above described case, held that trust funds remained in the account all day to the extent of \$252,760.24.

The decision of Judge Hand on the Princeton Bank claim was affirmed by the Circuit Court of Appeals, Second Circuit, in *In re Brown*, 193 Fed. 24. The claim of the Princeton Bank arose from moneys paid to Brown & Company by the Princeton Bank with which to buy stock. Brown & Company bought the stock, but then sold it and retained the proceeds. The Circuit Court of Appeals for the Second Circuit had ruled earlier that the Princeton Bank could not rescind and trace the money it paid to Brown & Company, but that it was entitled to the proceeds of the converted stock and should be permitted an opportunity to trace these proceeds if it could. 175 Fed. 769. The Circuit Court of Appeals gives more detailed facts than the trial court. Certain of the claimants' moneys were deposited in the Bank of Commerce and the court finds these were dissipated. Next the court took up the separate question of deposits of money of the Princeton Bank in the account of the bankrupt in the Hanover Bank prior to the 25th. These deposits had been made from August 13th to August 24th, and the special master had found that "the opening and closing balances in the Hanover Bank on and after August 13th were largely in excess of these deposits." The Circuit Court of Appeals held that this finding was not sufficient to show a tracing of the Princeton Bank's money into the account on August 24th for two reasons—1st: these balances might as well represent the trust money of other claimants (none of whom had been able to trace and who were therefore relegated to the position of general creditors, just as in the case of Richfield), and 2nd: that in any event opening and closing balances are not evidence that the entire account was not dissipated. The court said of the master's finding on opening and closing balances:

“But the finding is not sufficient; there is no reason why it should be assumed that these balances were being reserved because they represented the trust money of the Princeton Bank, rather than because they represented trust money of Simpson, or Scotton, or any of the other similarly situated enumerated above (aggregating \$21,783.39)—or, indeed, any of the other claimants who from time to time have appeared in this proceeding seeking to trace and recover for property converted by the bankrupts.

“*Moreover*, it is not enough to show that there were morning and afternoon balances for several successive days large enough to cover the amount of money which was improperly converted. It might very well be that on any one day checks were presented which exhausted the morning balance and its accretions, in which event these moneys would have been dissipated. We are not prepared to assent to the proposition that subsequent deposits are to be taken as having been made to make good claimant’s money thus drawn and spent. Board of Commissioners v. Strawn, 157 Fed. 51, 84 C. C. A. 553, 15 L. R. A. (N. S.) 1100. Our own conclusion would be that the \$1,757.50 of the proceeds of claimant’s stock, which went into the Hanover Bank on August 13th, has not been shown to be any part of the balance which was turned over by that bank to the trustee * * *”

In re Brown, 193 Fed. 24, 26.

The last mentioned decision of the Circuit Court of Appeals was not involved with anything that occurred in the account on August 25th. The court felt that possibly the special master and the trial court had some additional evidence as to what happened to the balance in the ac-

count during each day, so he then went on to consider transactions on the 25th. With respect to the deposit of the Princeton Bank on August 13th the court said:

“Nevertheless the master and the District Judge seem to have reached the conclusion that it remained in the account on August 24th. Since both of them had the same understanding of the law as that above expressed, viz., that the first check drawn on any given day might sweep away the balance carried over, *and that it would be the merest speculation* to assume that subsequent deposits restored the original situation, it is possible that they had some evidence, which is not in this record, as to the *continuous* condition of the daily balances prior to December 24th. Moreover, there is the deposit of claimant’s proceeds to the extent of \$280 on the 24th, which makes it necessary to consider the transactions of that day and the next.” (Italics ours.)

In re Brown, 193 Fed. 24, 26-27.

The court then found that sometime on the 25th the Hanover Bank account was drawn down to nothing, so that any tracing of funds deposited on August 13th or August 24th into the balance of the account remaining on the failure of Brown & Company on August 25th was impossible.

This opinion of the Circuit Court of Appeals was affirmed under the name *First National Bank of Princeton v. Littlefield* (1912), 226 U. S. 110, 57 L. Ed. 145, the court saying:

“The report of the master was confirmed by the district court (189 Fed. 432, 442), and the action of that court was in all respects affirmed by the circuit court of appeals (113 C. C. A. 348, 193 Fed. 24.)

* * *

“All the contentions relied upon in various forms simply assert that the master and the two courts erred in their appreciation of the facts. *But the burden of proof was upon the claimant to establish its ownership of the fund*—a burden which it cannot in reason be said was sustained in view of the concurrent adverse action of the master and the courts below.”

First National Bank of Princeton v. Littlefield,
226 U. S. 110, 57 L. Ed. 145.

Ex parte Schuyler, Chadwick & Burnham In re A. O. Brown & Co. (D. C., S. D., N. Y. 1911), 189 Fed. 432, 433-435, is one of the decisions relied upon by claimant. The opinion is written by Judge Hand, who it will be recalled had previously written the opinion in *Primeau v. Granfield* (D. C., N. Y. 1911), 184 Fed. 480. The Brown & Company bankruptcy gave rise to a number of claims, among them that of Schuyler, Chadwick and Burnham. The facts of the Schuyler claim were that the bankrupt had converted certain stock of Schuyler by selling it in a single batch along with other stock to Miller. This was done on August 24, 1908, and Miller gave the bankrupt two checks for the purchase price on that date, one for \$266,600.00 issued first, and one for \$23,000.00 issued later the same day. Judge Hand said that treating the obligation of Miller to pay for the stock as if it were a bank account, in the absence of other evidence, when the first check was drawn the claimant could say his money remained in the obligation of Miller; then when the second check was drawn for the balance of the obligation, the claimant's money was necessarily in it. In passing, it should be called to the attention of the Court that obviously such a holding does not involve any appli-

cation of the doctrine of *In re Oatway* as contended by Mr. Faries. It was conceded by the trustee in bankruptcy that the \$23,000.00 check had been issued to pay a loan which released collateral and that such released collateral or the proceeds thereof had come into the hands of the trustee. Upon these facts Judge Hand held that the proceeds of claimant's stock had been traced to property in the trustee's hands.

Judge Hand's decision in the District Court was reversed by the Circuit Court of Appeals, Second Circuit, in the case of *In re A. O. Broten & Co.*, 193 Fed. 30. The Circuit Court of Appeals stated that the larger check was deposited in the Hanover Bank in Brown & Company's account on the 24th of August and the smaller on the 25th of August. At noon on the 25th of August, Brown & Company made an assignment for creditors and the Hanover Bank turned over the balance of the account to the assignee, who in due course turned it over to the trustee in bankruptcy. The Circuit Court of Appeals said that it was not satisfied that the claimant's fund had been traced to the second check as distinguished from the first check, but that it made no difference since in its opinion the proceeds of neither check had been traced to the hands of the trustee in bankruptcy. It was established that some time on the morning of August 25th, probably about 11:00 o'clock A. M., the account with the Hanover Bank was drawn down to nothing by the certification of a check which exhausted the entire balance then in the account. There was a balance in the account, however, to turn over to the assignee for creditors at noon on the 25th. The Court said that if the claimant's money was in the earlier check deposited on August 24th it surely was in the balance remaining in the account at noon on

August 25th, since the account had been exhausted at one time on the morning of August 25th. The court further said that if claimant's funds were in the smaller check deposited on August 25th, claimant had failed to show that the amount claimed by him remained in the bank to the time it failed, because he had failed to show the relative order of the check which drew down the account and the deposit of \$23,000.00 in which he claims his funds were included. The court specifically found that the order of checks and deposits on the books of the bank could not be used, since the officers testified (as in the Universal case) that this order on the books was not necessarily the order of the actual transaction. In reversing the lower court, the Circuit Court of Appeals said:

“It is the theory of the claimant that this \$23,000 was not deposited until after the large check to A. H. Combs & Co. (\$146,600) had been certified; it being contended that for that reason the proceeds of claimant's stock, which it is claimed were included in the \$23,000 check, were not dissipated by the certification. To maintain this theory it is necessary for the claimant to show by competent proof which event occurred first, the certification or the deposit. * * *

“In order to establish the relative priorities of the certification and of the deposit of the \$23,000 check, it is necessary to show the time when both transactions took place. But as to the deposit there is no testimony whatever. In view of the circumstance that the deposit slip was prepared in the afternoon of the 24th, and that the condition of Brown & Co. was such as to call for the prompt deposit of everything they could control, it might fairly be inferred that the \$23,000 would be deposited on the 25th, as soon

as the bank opened; but it is not necessary to draw inferences. *It is for the claimant to show when the \$23,000 was deposited if that time is essential to his argument. He cannot trace his money by a mere succession of presumptions.* Some of the modern cases have gone very far—possibly in some instances too far—in helping out a claimant by presumptions not always reasonable; but in this circuit we have always required some substantive proof as a basis for holding that the owner of trust funds converted by a bankrupt has a lien on some particular part of the *bankrupt's property*. Carse, the vice-president, testified that the \$66,600 check was the first deposit on the 25th, to his recollection—a very uncertain recollection, as we have seen—but no one testified and no writing of any sort was introduced to show when the \$23,000 was deposited. We cannot therefore find that it was deposited after the certification, and, since the evidence establishes quite conclusively that the \$146,600 check was not certified until 11 a. m. or later, there is nothing to show that the \$23,000 check and all the others (except perhaps the \$17,300) were not absorbed by the certification. If the claimant's \$9,600 was included in the \$23,000 check, it was then dissipated and can be traced no farther.” (Italics ours.)

In re A. O. Brown & Co., 193 Fed. 30, 31, 32-33.

The decision of the Circuit Court of Appeals for the Second Circuit, which reversed the trial court, was affirmed by the United States Supreme Court in *Schuyler v. Littlefield* (1914), 232 U. S. 707. With respect to the moneys coming to the trustee's hands from the Hanover Bank, the Supreme Court agreed that the claim-

ant had not traced any trust funds to the balance on hand at noon on August 25th. It stated that if the trust fund was included in the check deposited on the 24th then it was dissipated, at least down to the closing balance on August 24th, and the remainder dissipated the next day. The statement of the court that it was dissipated down to the balance at the close of business on the 24th cannot by the widest stretch of the imagination be construed to be a holding by the court that the balance at the close of business on August 24th constituted trust funds. It merely shows that regardless of any other evidence the trust would have been entirely dissipated by reason of the closing balance on August 24th and the depletion of the account the next morning. Treating the trust fund as being included in the check deposited on the 25th, upon the lack of evidence as to the order of the checks and deposits on that day, the court affirmed the assumption of the trial court that the deposit of \$23,000 was made before the certification of the check which depleted the account.

The holding of this Honorable Court with respect to the Universal claim that, when the order of checks and deposits is not shown, Universal's money will be held to remain in the closing balance for the day is, we submit, wholly irreconcilable with the decision of the Circuit Court of Appeals, Second Circuit, expressly approved by the United States Supreme Court, to the effect that in the absence of a showing as to the order of checks and deposits even for one or two hours during the day, it must be found that the checks presented drew down the account and the trust funds cannot be held to continue to exist in the account to the full extent of the closing balance for the day.

A similar instance in the Richfield account is found on February 25, 1930. The facts as to that day were:

Opening Bal.	Checks.	Deposits.	Closing Bal.
296,779.62	425,191.72	281,172.34	252,760.24

Of the deposits, \$100,000 came from Universal. Contrary to the above described case affirmed by the United States Supreme Court, this court merely assumed that as the balance at the end of the day was over \$100,000 the deposit of Universal funds in that amount were shown to have remained in the account. It is respectfully submitted that since the checks for the day exceeded the opening balance by more than \$100,000, in the absence of any evidence as to when the deposit was made with relation to the checks and other deposits, the court should have held there had been no tracing of the trust deposit into the closing balance.

In *Connolly v. Lang* (C. C. A. 7, 1933), 68 Fed. (2) 199, the facts were that on June 22, 1932, a savings depositor in an outlying Chicago bank made a request to withdraw her deposit totalling \$9642.83 at that time. Her account sheet was pulled from the books and her pass-book marked to indicate the withdrawal. Upon her then explaining that she wanted to take the money to a downtown bank to buy a draft to go to Europe she was advised that the outlying bank could accommodate her. They gave her a draft on a New York bank for \$8,500.00 and the balance of \$1142.73 in cash. The bank wired \$5000.00 to the N. Y. bank which, in addition to its funds already with the N. Y. bank, were intended to cover the draft. June 22, 1935, was the last day the bank was open and next morning a receiver took over its assets

including the account in the N. Y. bank, so that the draft issued to the former depositor was never honored.

The depositor claimed the full \$8500.00 out of funds coming to the receiver. The court found that the funds of the bank at the closing thereof on June 22, 1935, and which were delivered to the receiver exceeded the amount claimed by the depositor.

The court said this was not sufficient to enable the depositor to succeed, saying:

“While it is found that at the time the bank was closed it had on hand more than the amount of appellee’s claim in cash, which appellant received, yet that does not necessarily mean that that sum included any part of appellee’s money. The cash balance of the bank, if any, at the beginning of business on June 22, 1932, is not disclosed, *nor are the deposits and withdrawals shown for that day*. Those facts if shown would reveal what funds, if any, the bank had at the time of appellee’s transaction. If, at that time, there were no funds in the bank except the amount she received in cash, and the amount wired to Central Hanover, then it is clear that there would have been no funds to which the alleged trust could attach except the money held by Central Hanover. *If the trust is once depleted, it can not be built up by subsequent deposits of other depositors.* Schuyler v. Littlefield, *supra*; Blumenfeld v. Union National Bank (C. C. A.), 38 F. (2d) 455; *In re Brown* (C. C. A.), 193 F. 24. We cannot say that the cash balance of the bank on the morning it failed to open was not received by the bank subsequent to appellee’s transaction.” (Italics ours.) *Connolly v. Lang*, 68 Fed. (2) 199, 201.

“If this were a controversy only between appellee and the bank there might be good reason for permitting fiction to pervert the facts because all the equities would be with appellee. This action, however, is really between appellee and the general depositors, who without fault on their part have been placed in positions which no doubt are equally deplorable and *whose rights to have equity done are equally worthy of consideration.*” (Italics ours.) *Connolly v. Lang*, 68 Fed. (2) 199, 202.

Mr. David R. Faries, in his brief *amicus curiae*, cites one additional case which he contends is authority for the contention that the burden of proof is on the receiver. In *Smith v. Mottley* (C. C. A. 6, 1906), 150 Fed. 266, cited on page 160 of Mr. Faries' brief, Mr. Faries misstates the facts, and it is only by reason of his misstatement that he can find any solace in this case. Mr. Faries states that the only proof was that the bank “had wrongfully received the beneficiary's money some ten days prior to the general assignment for the benefit of creditors.” The amount sought to be traced was \$2,315.23 received by the trustee on April 11, 1905. The court specifically found “From the 11th day of April to the time of making its assignment, the bank had on hand at all times more than \$7,000 in cash, and the assignee, who is now the trustee, received more than that sum.” Consequently, the claimant had sustained the burden of showing the continuous condition of the account at every minute in the intervening period. All discussion about the burden of proof being on the trustee in bankruptcy has to do with the burden of proof to show that the trust funds did *not* in fact remain in the low balance *after* the *cstui* has established what that low bal-

ance is. As said in *In re Brown* (C. C. A. 2), 193 Fed. 24, 29, the general language of *Smith v. Mottley* is controlled by the later decision in the same court of *Board of Commissioners v. Strawn* (C. C. A. 2), 157 Fed. 49. The other cases cited by Mr. Faries are discussed and shown to be clearly irrelevant on other pages of this petition.

It is respectfully submitted that the *only* evidence of low balance of the account is that provided by combining the overnight balances with a consideration of the amount of checks and deposits made each day, the burden of proof being on the claimant to show which if any deposits preceded which if any checks. In the absence of any proof of the order of the checks and deposits, it should not be assumed that any deposit was made before the checks were presented, at the expense of the other creditors of the estate. Mr. Faries' illustration on page 22 of his brief *amicus curiae* is misleading and incorrect. He says that if the opening balance was \$1,000.00 and a deposit for \$200.00 was made and thereafter a check for \$200.00 was cashed, the Master would assume that the low balance for the day was \$800.00. He is entirely incorrect in his prediction of what the Master would find. *If* Universal had been able to show the order of checks and deposits, as assumed by Mr. Faries, the Master would have found that the low balance for the day was \$1,000.00.

It is submitted that the very fact that the court rules that the burden of proof as to an essential element of tracing is on the Receiver shows conclusively that some fact in the tracing is missing and that Universal has not completed a tracing of its funds. To shift the burden

of proof to the receivership estate and the creditors, or to dispense with proof in any other manner, is merely granting an improper preference to Universal while attempting to disguise it under the name of tracing trust funds.

In *Jennings v. U. S. Fidelity & Guaranty Co.* (1935), 79 L. Ed. Adv. 355-360, a state statute attempted to provide a trust for a certain class of creditors without the necessity of tracing. The Supreme Court, in refusing to apply this statute to a receivership of a national bank, said:

“A trust so created, to arise upon insolvency, is a preference under another name. As applied to a national bank, the preference is plainly inconsistent with the system of equal distribution established by the federal law.”

Jennings v. U. S. Fidelity & Guaranty Co., 79 L. Ed. Adv. 355, 360.

In *In re Mulligan* (D. C. Mass. 1902), 116 Fed. 715, 718, the court says that since a tracing is proper and a preference is improper, the court should not disguise a preference as a tracing by shifting the burden of proof, saying:

“* * * to change the cestui’s claim for priority into a mere shifting of the burden of proof finds no considerable support in the decided cases.”

In re Mulligan (D. C. Mass. 1902), 116 Fed. 715, 718.

III.

The Supreme Court of the State of California Has Established as a Rule of Property for that State That as Against Creditors of a Trustee ex Maleficio the Cestui Has No Interest in a Bank Account of the Trustee in Which Funds of the Cestui and Trustee Have Been Commingled After Checks to the Amount of the Cestui's Funds in the Account Have Been Charged Against That Account. Under This Rule of Property and the Facts Established in This Case, Universal Had No Interest in the Richfield Bank Account at the Time the Several Investments, Which Are the Subject of This Proceeding, Were Made and Consequently Could Have No Interest in the Investments. As Both the Bank Account and All of the Properties Involved Are Properties in the State of California, and in Most Cases Are Interests in Real Property in the State of California, the Above California Rule of Property Should and Must Be Followed by the Federal Courts.

In his Brief *Amicus Curiae* in this proceeding, Mr. David R. Faries calls the Court's attention to a portion of the opinion in *Mitchell v. Dunn* (1930), 211 Cal. 129, claims that this establishes the law of California in favor of the contentions of Universal, and asserts that the California decision should be given great consideration. We deny that, under the facts of this case with the trustee insolvent, Universal can find any solace in the decisions of California. See *Mitchell v. Dunn*, *supra*, page 136. Rather, it is submitted, that under the facts established in this case, the established rules of property in California deny any interest in the properties in question to Univer-

sal, and such rules of property not only should be considered by, but are binding upon, the federal courts.

The California Supreme Court has rendered a long line of decisions on the tracing of trust funds. Long before the high court of England (*Knatchbull v. Hallett*, 1880, L. D. 13, Ch. Div. 696, 743) and the high court of the United States (*National Bank v. Insurance Co.*, 1881, 104 U. S. 54) relaxed the early rule that if trust moneys were commingled with the moneys of the trustee, they could no longer be traced, the California Supreme Court reached this same more liberal conclusion in the case of *Gunter v. Jancs* (1858), 9 Cal. 643, 660-661. In that case a *cestui que trust* was permitted to recover his money from a commingled fund, there being no creditors of the trustee involved, the court saying:

“We cannot perceive, upon considerations of principle or utility, why the mingling of trust with private moneys, by the voluntary act of the trustee, should destroy the trust fund, and change the remedy or right of the beneficiary. It is true, money has no earmarks; and, for that very reason, the mingling of trust with private funds can injure no one. The value being the same, and it being matter of the most perfect indifference whether parties get the same or other coin, so they get the sum to which each is entitled, there can result no injury to either. Common sense will not discuss the question of identity, when nothing useful can result from its determination.”

In speaking of several English cases not permitting a trust in commingled funds, the court said:

“But these cases are clearly distinguishable from the case before us. There the rights of creditors

were involved, while here the contest is solely between the *cestui que trust* and the administrator of the trustee.”

Gunter v. Janes, 9 Cal. 643, 660-661.

After a full consideration of the decisions *in re Hallett's Estate, supra*; *National Bank v. Insurance Co., supra*, and other Federal and California cases, the California Supreme Court decided that in California, as against creditors of an insolvent trustee *ex malificio*, the *cestui* had no interest in a bank account of the trustee in which the *cestui's* money had been commingled with that of the trustee if the amount of checks charged against the account from the time of the deposit of the *cestui's* funds exceeded the amount of such funds.

People v. California Safe Deposit & Trust Co. (1917), 175 Cal. 756.

In the latter case the Trustee Company fraudulently induced claimant to buy its stock for \$12,000.00. The Trust Company went into insolvency proceedings and the claimant sought to impress a trust upon funds coming into the Trust Company receiver's hands. The evidence shows that the Trust Company's cash never fell below \$123,000 between the time claimant bought the stock and the time the Trust Company closed its doors. Meanwhile about \$6,000,000.00 of deposits and withdrawals were made. The lower court said that the presumption that claimant's funds were still in the bank did not apply against creditors where the trustee was such by reason of his own fraud and held that claimant had failed to trace his funds into the balance taken over by the receiver. The Appellate Court affirmed the judgment against claimant, saying:

“Upon this appeal the appellant insists that he was entitled to payment in full, rather than as a general or common creditor. His position is that the bank became an involuntary trustee of the twelve thousand dollars which it had obtained from him by fraud (Civ. Code, sec. 2224), and that he had sufficiently traced this trust fund into the hands of the receiver to be entitled to payment in preference to general creditors. It is well settled that the beneficiary of a trust may follow and recover the trust fund if any property in the hands of the trustee or of those taking with notice can be identified either as the original property of the *cestui que trust*, or as the product of it. (Thompson’s Appeal, 22 Pa. St. 16.) Where, however, the identity of the trust fund has been lost, the beneficiary is relegated to the position of a general creditor, and must share pro rata with other general creditors. (Lathrop v. Bampton, 31 Cal. 17, 89 Am. Dec. 141.)

“The appellant insists that upon these facts the court was bound to find that the twelve thousand dollars received from him, as aforesaid, remained intact in the hands of the bank during the entire period intervening between the purchase of the stock and the closing of the bank, and that such fund had been identified and traced into the hands of the receiver. The argument is that since it appears that the bank had on hand at all times a sum in excess of twelve thousand dollars, the amount claimed by the petitioner, it must be presumed that it retained this sum to meet his claim arising from the fraud perpetrated upon him. The argument is based upon the well-settled rule that if a trustee mingles his own funds with the trust fund, and thereafter draws from time to time from the commingled mass, ‘it will be pre-

sumed that the moneys so drawn were from his own portion of the fund, rather than from the moneys held by him in trust.' (Elizalde v. Elizalde, 137 Cal. 634, 641 (66 Pac. 369, 70 Pac. 861); *In re Hallett's Estate*, L. R. 13 Ch. Div. 696; *National Bank v. Insurance Co.*, 104 U. S. 54 (26 L. Ed. 693); *Lewin on Trusts*, 895.) Various expressions have been used in defining the nature of the rule. In some of the cases, as pointed out by the appellant, it has been said that equity will 'attribute' the withdrawals to the trustee's private account. In others, as in the *Elizalde* case above cited, it is said that the trustee will be 'presumed' to have drawn his own money. In one case (*Crawford County Commrs. v. Strawn*, 157 Fed. 49 (15 L. R. A. (N. S.) 1100, 84 C. C. A. 553)), the doctrine is explained as resting upon a 'fiction'. *But whatever name be given to it, the rule originates in and rests upon the underlying presumption 'that a person is innocent of crime or wrong.'* (Code Civ. Proc., sec. 1963, subd. 1.)

"Has the doctrine any proper application to a case, like this, where a party has fraudulently induced another to enter into a contract, and holds what he has received thereunder in trust, not by virtue of any contractual or acknowledged fiduciary relation, but merely because the law declares that he is an involuntary trustee of property obtained by fraud? Is it to be presumed that one who has obtained property fraudulently under an agreement whereby it becomes his own (subject merely to the other party's right of rescission) will, notwithstanding his acquisition and holding under a claim of ownership, keep the property intact, for the benefit of the one from whom he has obtained it? *Can the wrongful act of the party obtaining the money furnish the basis for making him*

a trustee, and at the same time the ground for presuming that he acts rightfully? These questions have been directly presented to the supreme court of Iowa, which has answered them by saying that the rule relied upon by the appellant does not apply to involuntary trusts arising solely from fraud. In *In re First State Bank of Corwith*, 149 Iowa, 662 (129 N. W. 70), that court said: 'While we have held that where a bank receives money wrongfully, a trust arises as between it and the true owner of the money, we have never held that the wrongful act of the bank will alone create a preference as against general creditors, Are the appellees herein entitled to the aid of the legal presumption that their money reached the hands of the receiver in the form of increased assets of the bank, and that it may be taken therefrom without impairing the rights of the general creditors? *We are of the opinion that an affirmative answer to the inquiry would require us to go a step further than we have ever gone, and to establish a rule that would be unjust and inequitable. . . .* In all of our cases, except one which will be noticed later, where the presumption has been given force, the deposits were of trust funds, the character of such funds was known to the banks when the deposits were made, and the deposits involved no wrongful act on the part of the banks. *The presumption was in every instance based on the theory that the bank, knowing the character of the fund and acting honestly, would not use or dissipate it as long as it had funds of its own.*' The court then goes on to explain *Whitcomb v. Carpenter*, 134 Iowa 227 (10 L. R. A. (N. S.) 928, 111 N. W. 825, the exceptional case to which it had referred, by saying that the bank had there become a trustee by contract. 'But in any event,' continues the opinion,

'we do not think that it can be presumed that a bank will keep money that it has obtained by means of wilful and deliberate criminal acts. The ordinary thief disposes of stolen property as soon as possible, and it would be going a long way to say that a bank that has obtained money by means of its deliberate forgery will be presumed to have kept it on hand to be returned to the injured party intact. We are not willing to so hold, and without such presumption the appellees have made no showing that entitles them to preference.'

"The appellant is not correct in his statement that the case just cited has been overruled. On the contrary, it has been approved in a later decision by the same court. (In re First State Bank, 152 Iowa 724 (133 N. W. 354).) Nor are we cited to any authorities holding the contrary. In re Hallett's Estate, L. R. 13 Ch. Div. 696, a leading case, is relied on by the appellant. It does not, however, hold that the presumption applies to cases like the one before us. It merely holds that it is applicable not merely to the technical relation of trustee and *cestui*, but to all relations of a fiduciary character, as, for example, that of principal and agent. In all of the other cases cited, the money in question was either received in trust or was taken from a trustee with notice of the character in which he held it.

"There is, of course, no pretense that petitioner has traced, or can trace, his twelve thousand dollars into the possession of the receiver, except by means of the artificial presumption or fiction upon which he relies. *The controversy, in its essence, is between the petitioner and other claimants whose only recourse is to a fund insufficient to meet the demands upon it. All*

concerned must suffer some loss through the mismanagement or misconduct of the officers of the bank.” *People v. Calif. Safe Dep. & Trust Co.* (1917), 175 Cal. 756, 759, 760-762.

Even in the case of *Knatchbull v. Hallett*, *supra*, which is the foundation of the “low balance” presumption, the distinction between ordinary fiduciaries and a trustee *ex maleficio* was recognized. Contrary to the statement in the opinion of this Court, no tortfeasor was involved in the English case. Baggallay, L. J., expressed the view in the English case that since the low balance theory was based on a fiction of honesty, it could be rebutted, and would be rebutted by proof of dishonesty such as that the funds were improperly taken in the first instance, or that the trust was repudiated as would be shown by a drawing of the total in the account below the amount of the trust funds. *Knatchbull v. Hallett*, 13 Ch. Div. 696, at 743.

The case of *Mitchell v. Dunn* (1930), 211 Cal. 129, 136, was a case involving a solvent trustee, and the court expressly recognized that it would indulge in presumptions against a solvent trustee which would be unwarranted against other creditors if the trustee were insolvent.

While the rule of property is established by the California Supreme Court for California property, we desire to call attention of this court to a few of the decisions of other courts which have refused to apply a “low balance”

presumption under circumstances similar to those existing in the *Richfield* case.

Rugger v. Hammond (Wash., 1916), 163 Pac. 408;

Philadelphia Nat'l Bank v. Dowd (C. C. N. C., 1889), 38 Fed. 172;

Poole v. Elliott (C. C. A. 4, 1925), 76 Fed. (2d) 772, 774, 775;

Stilson v. First State Bank (Ia., 1910), 129 N. W. 70, 72, 73;

American Employers' Inc. Co. v. Maynard (Mich., 1929), 226 N. W. 686.

It is of course obvious that if Universal had no property interest in the bank account of Richfield at the time the checks were drawn on that account to make the investments which are the subject of this proceeding, Universal could not possibly trace any property interest into the investments themselves. It is equally obvious that upon the application of the above rule of property established by the California Supreme Court and the facts adduced in this case, Universal established no property interest in the bank account of Richfield at the time any of the investments in question were made. The facts in evidence show that in every instance the amount checked against the account, between the time each deposit of Universal funds was made in the account of each such deposit of Universal funds. The following is a schedule of said facts in evidence:

Date of Deposit	Amount of Deposit	Closing Balance	Date of first subsequent disbursement for properties sought to be traced	Total disbursements from the account between two dates immediately to the left
Nov. 13, '29	\$750,000.00	\$2,417,148.32	Nov. 29, '29	\$5,074,049.65
Jan. 20, '30	200,000.00	1,242,607.82	Jan. 27, '30	1,795,588.66
Feb. 15, '30	500,000.00	1,128,227.19	(Next deposit)	
			Feb. 25, '30	2,705,967.54
Feb. 25, '30	100,000.00	252,760.24	(Next deposit)	
			Feb. 27, '30	48,621.95
Feb. 27, '30	100,000.00	608,346.67	Mar. 1, '30	222,073.94
June 6, '30	75,000.00	216,959.33	June 25, '30	3,347,662.88

Referring to the above schedule it appears that on November 13, 1929, the first deposit of so-called "trust funds" from Universal was made in the general account of Richfield with Security-First National Bank of Los Angeles. At the close of that same day, due to other funds of Richfield being in the account, the balance in the account was \$2,417,148.32. Between that time and the opening of the account on November 29, 1929, the date the first disbursement was made for the properties sought to be traced, there had been disbursed from the account \$5,074,049.65, even without taking into account additional checks charged to the account on Nov. 13, 1929, after the deposit in question. Counsel for Universal on these facts ask the court to find that they have proved that the \$750,000 in trust money did not go out with said disbursement of \$5,074,049.65, but through some fortuitous circumstances still remained in the account, at least to the extent of the lowest balance of the account between November 13 and November 29. Such proof would, of course, be no proof at all but would merely be dispensing with proof in the guise of a fiction or presumption, which under the circumstances of this case *and under the decision of the Supreme Court of California* does not exist. Without the aid of such fiction or presumption as a substitute for

proof, it will be seen from the schedule immediately preceding that Universal has not shown that a single dollar of the trust funds was in the account at the times any of the disbursements therefrom sought to be traced were made.

It is of course true that if state court decisions attempt to create preferences and priorities without any tracing, the state rule is one of preference rather than of property, and the federal decisions on general equity jurisprudence are controlling as to preference in receiverships.

John Deere Plow Co. v. McDavid (C. C. A. 8, 1905), 137 Fed. 802, 812;

Beard v. Independent District of Pella City (C. C. A. 8, 1898), 88 Fed. 375;

Elmer v. Kemp (C. C. A. 9, 1933), 67 Fed. (2d) 948, 952.

But the question of whether or not a trust interest under given facts actually exists on certain real or personal property is a question of property law. For example, since the tracing of a trust *res* is a matter of property right rather than debt, the California Supreme Court has permitted a *cestui* to recover funds from a mixed bank account of a decedent although the *cestui* had not filed a claim against the estate within the proper time to recover on a debt. *Noble v. Noble* (1926), 198 Cal. 129.

The question of whether a *cestui* has an interest in real or personal property is so clearly a question of property that it is cognizable by the state courts, even in the case of an insolvent national bank. If it were a matter of

preference rather than of property rights, the federal courts would have exclusive jurisdiction under a national bank receivership. *Davis v. Elmira Savings Bank* (1896), 161 U. S. 275, 283-4, 288-290. Nevertheless, on a question of the actual tracing of trust funds, this being a question of local property rights, state courts have jurisdiction even in the case of the insolvency of national banks. *Capital National Bank of Lincoln v. First National Bank of Cadis* (1899), 172 U. S. 425, 432-433. In the latter case a state court decided that certain funds in the hands of a receiver of a national bank had been traced as trust funds. The court distinguished this from the case of a preferred claim, held that no federal question was involved, and upheld the jurisdiction of the state court to decide the point, saying:

“The contention of plaintiff was that the Capital National Bank had money in its hands which belonged to plaintiff, did not belong to the bank, had never formed part of its assets, and was held by the bank in trust for plaintiff.

“The right to the money was considered by the trial court in the light of general equitable principles applicable on the facts, and the court adjudged that the money constituted a trust fund to which plaintiff was entitled.

“The decision did not purport to affect the assets of the bank, or attempt to direct the distribution thereof, or in any way to interfere with the disposition of assets actually belonging to the bank; nor did it affect the receiver as receiver; or his appointment or authority under the banking act. As the trial court found that certain moneys held by the bank in trust for plaintiff had come into the receiver's hands, he

was directed to return them, for he had no stronger title to the trust fund as against the plaintiff than the bank had.

“* * * it is clear that the state courts had jurisdiction to determine whether this money was or was not a trust fund belonging to plaintiff.” *Capital Nat. Bk. of Lincoln v. First Natl. Bk. of Cadiz*, 172 U. S. 425, 432, 435.

While the last two cases cited from the United States Supreme Court are with respect to the jurisdiction of a state court, they clearly distinguish between a preference in receivership as a mere principle of equitable jurisdiction and a tracing of trust funds as a property right, which is a matter of local property law.

It is submitted that all questions of local property rights, both with respect to real and personal property, are governed by the decisions of the highest court of the state in which the property is situated, even when the case is in the federal courts.

Edward Hines Yellow Pine Trustees v. Martin,
268 U. S. 458, 464; 69 L. Ed. 1050, 1053 (1925);

Scandinavian-American Bank v. Sabin (C. C. A.
9, 1915), 227 Fed. 579, 582;

Pickens v. Merriam (C. C. A. 9, 1915), 274 Fed.
1, 8;

Jones v. Harrison (C. C. A. 8, 1925), 7 Fed. (2)
461, 464; Cert. den. 270 U. S. 652.

As succinctly said in Vol. 6, *Hughes Federal Practice*, section 3712, pp. 238-9:

“In considering generally the question whether or not the decisions of the state courts are binding on

the federal courts, reference was made to matter decided relating to local property rights, to the effect that when the thing decided in a state court relates to the acquisition, or not, of rights to, interest in, or liens upon, property located within the state, even though the acquisition, or not, depends solely upon the unwritten law of the state, the decision is to be followed in a federal court sitting in that state." Vol. 6, Hughes Federal Practice, Sec. 3712, pp. 238-9.

In *Edward Hines Yellow Pine Trustees v. Martin* (1925), 268 U. S. 458, 464; 69 L. Ed. 1050, 1053, the Supreme Court, in considering a bill in equity to remove a cloud on title to real property, said:

"To avoid the uncertainty and injustice which result from 'the discordant element of a substantial right, and which is protected in one set of courts and denied in the other, with no superior to decide which is right' (*Brine v. Hartford F. Ins. Co.*, 96 U. S. 627, 24 L. Ed. 858), this court has not hesitated when there has been a conflict of decision between it and the state courts, affecting a rule of property within the state, to overrule its own decisions and to follow the state decisions once it has become evident that they have established a 'rule of property' as the settled law of the state (*Green v. Neal*, 6 Pet. 291, 8 L. Ed. 402; *Suydam v. Williamson*, 24 How. 427, 16 L. Ed. 742; *Fairfield v. Gallatin County*, 100 U. S. 47, 25 L. Ed. 544; *Roberts v. Lewis*, 153 U. S. 367, 376, 38 L. Ed. 747, 750, 14 Sup. Ct. Rep. 945; and see *Bauserman v. Blunt*, 147 U. S. 647, 37 L. Ed. 316, 13 Sup. Ct. Rep. 466, overruling a decision of the circuit court ante-dating a conflicting decision of the state court). We, are, therefore, constrained in the present case to accept the view of the state courts as

announced by them without inquiring, as an original proposition, into the justice and sufficiency of the rule which we follow." *Edward Hines Yellow Pine Trustees v. Martin*, 268 U. S. 458, 464; 69 L. Ed. 1050, 1053.

In this respect there is no distinction between real and personal property, for, as said in 6 *Hughes Federal Practice*, section 3715, p. 248:

"The decisions of the state courts as to personal property are rules of property, as are those involving realty, to be followed by the federal courts." 6 *Hughes Federal Practice*, section 3715, p. 248.

In *Scandinavian-American Bank v. Sabin* (C. C. A. 9), 227 Fed. 579, 582, the Circuit Court of Appeals for this circuit said:

"In determining the validity of chattel mortgages in bankruptcy proceedings, the federal court will follow the settled law of the state in which the transaction occurred." *Scandinavian-American Bank v. Sabin* (C. C. A. 9), 227 Fed. 579, 582.

In *Pickens v. Merriam* (C. C. A. 9, 1915), 274 Fed. 1, 8, the question was whether real property in Kansas which the deceased had contracted to sell before his death was to be regarded as real property going to his widow, or as personal property divisible between his widow and other claimants. The Circuit Court for this circuit said:

“It is stated by Judge Story in his work on Equity Jurisprudence (volume 2, par. 1107):

‘It is the exclusive province of the courts of the state of the situs of the property to determine its ownership, and its devolution to transfer, and whether or not there has been a conversion of the property from one sort to another. This is essentially so from the very nature of things, or else the state would have certain classes of property within its boundaries completely subject to the caprice and desires of non-residents, and thus render nugatory its laws enacted for the purpose of protecting its own citizens and their property rights.’

“That the decisions of the Kansas Supreme Court have established a rule of property as respects contracts of the kind involved here can scarcely be disputed. The construction of the contract given in the Pickens Case, *supra*, seems to have been first announced in Douglas County v. U. P. Ry. Co., 5 Kan. 615, 621, and has since been consistently followed. Brown v. Thomas, Sheriff, 37 Kan. 282, 15 Pac. 211; Drollinger v. Carson, 97 Kan. 502, 155 Pac. 923.

“These considerations lead to the conclusion that these contracts of sale did not work an equitable conversion of the real property concerned; that in their legal status, in view of the construction given them by the Kansas Supreme Court, they were properly to be considered and treated as real property, in the hands both of the vendor and his estate; and that they were rightfully so regarded in the administration and settlement of the estate. This disposes of the \$22,-965.75 item. The complainants could have no right, title, or interest therein.” Pickens v. Merriam (C. C. A. 9), 274 Fed. 1, 8.

In *Jones v. Harrison* (C. C. A. 8, 1925), 7 Fed. (2d) 461, 464, certiorari denied under name *Jones v. Readey*, 270 U. S. 652, the court said that as between the English rule restricting spendthrift provisions in trusts and the American rule which permitted such provisions to be more often enforced against attaching creditors, the state decisions should govern, saying "Whether the American rule shall be applied to equitable interests under a trust is a local rule of property binding on federal courts."

It is respectfully submitted that the California Supreme Court decision is binding upon and must be followed by the federal courts. Under that decision, and under the facts of the instant case, Universal had no property interests in the bank account of Richfield at the time the investments were made. The trust having failed at that time, there is no possibility of tracing any trust funds into the property purchased with checks drawn on the bank account thereafter.

IV.

Under the Circumstances of This Case, When Funds of a Cestui Are Commingled in a Single Bank Account With Funds of the Tortfeasor Trustee and Investments Are Later Made From Said Bank Account, the Cestui Cannot Claim Any of Such Investments at the Expense of the Other Creditors Against the Trustee's Insolvent Estate Unless the Cestui Sustains the Burden of Proving (1) That Trust Funds Remained in the Account at the Time the Investment Was Made; and (2) That the Trust Funds So Remaining in the Account Were in Fact (and Not Merely Presumptively) Appropriated for the Purpose of Making the Particular Investment. It Is Submitted That Universal Has Not Sustained the Burden of Proof With Respect to Either of These Elements.

It is submitted that under point III of this petition, the authorities cited demonstrate that the established rules of property of California applicable to this case necessarily deny to Universal any interest in the bank account at the time the investments which are the subject of this proceeding were made. But in addition thereto, under the well-established principles adopted by the United States Supreme Court and the great weight of authority of other courts in this country, a *cestui* must prove that trust funds in a commingled account were intentionally appropriated to a particular investment before the *cestui* can claim that investment or any interest therein as against

creditors of the trustee, and Universal equally failed to introduce any evidence on this essential element.

Peters v. Bain (1889), 133 U. S. 670;

Ex Parte Schuyler, Chadwick & Burnham In re A. O. Brown & Co. (D. C. S. D. N. Y. 1911), 189 Fed. 432, 433-435. Reversed under name *In re A. O. Brown & Co.* (C. C. A. 2, 1912), 193 Fed. 30. Reversal by C. C. A. affirmed under name *Schuyler v. Littlefield* (1914), 232 U. S. 707, 58 L. Ed. 806;

Ex Parte First Nat. Bank of Princeton in re A. O. Brown & Co. (D. C. S. D. N. Y. 1911), 189 Fed. 432, 437-439. Affirmed under name *In re Brown* (C. C. A. 2, 1912), 193 Fed. 24. Affirmed under name *First Nat. Bk. of Princeton v. Littlefield* (1912), 226 U. S. 110;

Ferris v. Van Vetcher (1878), 73 N. Y. 113;

Board of Com'rs of Crawford County v. Strawn (C. C. A. 6, 1907), 157 Fed. 49;

Bright v. King (1898 Ky.), 20 Ky. Law Rp. 186;

Bevan v. Citizens National Bank of Lebanon (Ky. 1893), 19 Ky. Law Rep. 1261;

In re City Bank (D. C. Mich. 1910), 186 Fed. 413;

Gianella v. Momsen (Wis. 1895), 63 N. W. 1018;

Burnham v. Barth (Wis. 1895), 62 N. W. 96;

Standish v. Babcock (1894), 50 N. J. Eq. 628;

City of Spokane v. First National Bank of Spokane (C. C. A. 9, 1895), 68 Fed. 982;

Empire State Surety Co. v. Carroll County (C. C. A. 8, 1912), 194 Fed. 593, 605.

In the leading case in this country on the subject of tracing investments from commingled funds, *Peters v. Bain* (1889), 133 U. S. 670, we find facts very similar to those in the instant case except that they were more favorable to the *cestui*, both in the matter of the unfairness which gave rise to the trust and in the matter of the relative amounts of the trust moneys and the trustee's personal funds. In that case a brokerage firm had been organized in 1865 with a capital of \$5,000, which was never increased. The brokerage firm obtained control of the bank in 1870 and proceeded to make use of the bank's funds for the firm's purposes, taking \$1,443,462.99. Both the brokerage firm and the bank went into liquidation. The brokerage firm had purchased some assets directly with the funds of the bank. The court held that such of these assets as came to the assignee of the brokerage firm, called in the decision "properties of the first class", were impressed with a trust in favor of the bank. However, the court held that with respect to assets purchased with the general funds of the firm, with which had been mingled the bank's funds, called "properties of the second class", no trust could be allowed, saying:

"The property in the second class, however, occupies a different position. There the purchases were made with moneys that cannot be identified as belonging to the bank. The payments were all, so far as now appears, from the general fund then in the possession and under the control of the firm. Some of the money of the bank may have gone into this fund, but it was not distinguishable from the rest. The mixture of the money of the bank with the money of the firm did not make the bank *the owner of the whole*. All the bank could in any event claim

would be the right to draw out of the general mass of money, *so long as it remained money*, an amount equal to that which had been wrongfully taken from its own possession and put there. Purchases made and paid for out of the general mass cannot be claimed by the bank unless it is shown that its own moneys *then* in the fund were *appropriated for that purpose*. Nothing of the kind has been attempted here, and it has not even been shown that when the property in this class was purchased, the firm had in its possession any of the moneys of the bank that that could be reclaimed in specie. To give a *cestui que trust* the benefit of purchases by his trustees, it must be satisfactorily shown that they were *actually made with trust funds.*” *Peters v. Bain* (1889), 133 U. S. 670, 678.

Reiterating in a later part of the decision:

“Purchases made and paid for out of the general mass cannot be claimed by the bank, unless it is shown that its own moneys *then* in the fund were *appropriated* for that purpose. And this the evidence fails to establish as to any other property than that designated in this decree.” *Peters v. Bain* (1889), U. S. 670, 694.

It should be noted that this language of the United States Supreme Court succinctly states the necessity for the elements herein designated “1” and “2” for the tracing of investments from commingled funds, to-wit: that trust funds must be shown to have been in the commingled funds at the time the investment was made, and further that it must be shown that the disbursement made from the commingled fund was intended by the trustee as an appropriation of trust funds for such disbursement.

The *cestui* might show direct appropriation of trust funds from the bank account to a particular investment by evidence of different sorts such as (1) evidence of the similarity in the amount of trust funds in the account and the amount invested, as suggested in *Ferris v. Van Vechter* (1878), 73 N. Y. 113; (2) statements of the trustee to the effect that he was appropriating trust funds for a particular investment, as in *Moore v. Jones* (1883), 63 Cal. 12 and *Taylor v. Morris* (1912), 163 Cal. 717; (3) by "direct evidence" of the appropriation, probably by entries on the books of the trustee, as in *Fiman v. State of South Dakota* (C. C. A. 8, 1928), 29 Fed. (2) 776; or (4) by evidence that the whole balance of the account, which balance included trust moneys, was invested in a single property, as in *In re A. O. Brown & Co.*, D. C. S. D. N. Y., 189 Fed. 432.

The authorities which are cited in support of the contrary rule do not establish the principle for which they are cited. *Primeau v. Granfield* (D. C. N. Y., 1911), 184 Fed. 480, was a case of a solvent trustee, and as is abundantly pointed out in the authorities, the court is warranted in making almost any assumptions or presumptions it wishes in order to make the *cestui* whole at the expense of a defaulting trustee, where other creditors are not involved. The case of *In re A. O. Brown & Co.* (D. C. N. Y.), 189 Fed. 433, is discussed *supra*. The portion about tracing investments merely held that if trust funds are included in the balance of a commingled account, and all of the balance of the commingled account goes into a single investment, the trust funds must necessarily be included in the investment. The case of *In re Pacat Finance Corp.* (C. C. A. 2, 1928), 27 Fed. (2) 810, 814, has the elements of a

proved appropriation of trust money on direct evidence, and furthermore, the real basis of the decision is the fact that the court regarded the lire credits as cash in the bank, stating that the principle against restoration of a low balance by subsequent deposits "does not apply to cash in bank, and lire credits we regard as of that class". The court did cite *In Re Oatway*, but that citation was unrelated to the principles upon which the court decided the case and entirely unnecessary to its decision. In *Fiman v. State of South Dakota* (C. C. A. 8, 1928), 29 Fed. 2d 776, there was obviously, as the court found, "direct evidence" of the appropriation of the trust funds for deposit in the correspondent banks. There was no contested issue on this point, and undoubtedly there were entries made on the books, or some such evidence of the actual appropriation of trust moneys. In any event, the court's decision expressly rests upon the "direct evidence" of appropriation, and not upon any presumption. *Brennan v. Tillinghast* (C. C. A. 6, 1913), 201 Fed. 609, must either be considered as contrary to the great weight of authority, as it is according to the language of the opinion, or as being one of those numerous cases holding that all of the "cash items" of a bank, including cash in its vaults and that on deposit with correspondents, is to be considered as a single fund. This is the one federal case in insolvency proceedings which purports to follow the supposed rule of *In re Oatway*.

So much has been made of the case *In re Oatway* (L. R. 1903), 2 Ch. Div. 356, that a discussion of the same at this time, we believe, would be very profitable. That was a case of a creditor's action for the administration of the estate of Louis J. Oatway, a solicitor, who died

insolvent in 1902. The testator Oatway died with one thousand shares of the stock of Oceana Company standing in his name, which were thereafter sold for 2474£/19s. The issue was over title to these proceeds. Oatway and Skipper had been co-trustees under a will. They advanced 3000£ to Skipper in breach of the trust upon the security of a mortgage. On August 15, 1901, Oatway sold the property as mortgagee and also under a power of attorney which he held from Skipper, realizing 7000£ upon the sale. At that time Oatway had 77£/13s/4d in his personal account and deposited the 7000£ therein. On August 24, 1901, Oatway purchased the shares in question for 2137£/12s/3d, having since August 13, 1901, made deposits in the account of some 30£ and having drawn out of the account some 510£. After August 24, 1901, the balance of the account was dissipated. Skipper, on August 15, 1901, was indebted to Oatway in the approximate sum of 1779£ and also in further unascertained amounts. The proceedings are brought by Skipper to have the proceeds of the stock paid to him, *either in his personal capacity because of the 4000£ received by Oatway on the sale over the amount of the mortgage or as trustee to replace the 3000£ lent.*

The contention of counsel for Skipper was that the entire 7000£ were trust funds, that Oatway had first to replace the 3000£ and had to account to Skipper for the balance of 4000£, but counsel stated that Skipper did not desire to press his personal claim to the proceeds of the shares provided the trust was given the benefit of them, he to be relegated to recover against Oatway's estate. The court stated that Skipper, who was himself a party to the original breach of trust, could not under the cir-

cumstances, and in fact did not, oppose the claim of the trust to the proceeds of the Oceana shares, so that for the purposes of the case it was considered that Oatway was entitled to the balance of the 7000£ after discharging the 3000£ mortgage. The court held that the fact that the account still contained enough to discharge the trust at the time the shares were bought would not prevent the trust from having a claim on the shares when the balance of the account was dissipated. It is submitted that the decision is only applicable to the peculiar facts of that case. The trust had had a lien upon the Skipper property which had been mortgaged. The proceeds from the sale of that mortgage were deposited in an account in which only a very small amount of the trustees' own personal funds were deposited. The investment was made nine days after the deposit, at which time very little had been withdrawn from the account, so that the requirement that the trust funds be shown to be in the account at the time of the investment was satisfied. Skipper's counsel evidently did not concede that the balance of the sales money belonged to Oatway. Rather, he contended that Oatway was obligated to him for the balance of such sales price, but was willing to waive his claim to the proceeds of the shares provided the trust got the benefit thereof. It is highly probable that the entire 7000£ were trust moneys for two different *cestuis*, one of whom has waived his claim provided the other is given the investment. If the entire 7000£ was a trust fund, even though one *cestui* waived his rights provided the other were given the investment, the investment was necessarily made from trust funds. In any event, *since* the decision of *In re Oatway* the United States Supreme Court has announced

a diametrically opposed rule under facts similar to those surrounding the Universal claim.

In *Schuyler v. Littlefield* (1914), 231 U. S. 707, 58 L. Ed. 806, the court was very specific in saying that there must be evidence of the appropriation of trust money from a commingled account to a specific investment before there can be a tracing into that investment. In the case below in the Circuit Court of Appeals, Second Circuit, *In re A. O. Brown & Co.*, 193 Fed. 30, 33, the claimant had traced his funds into an indebtedness owed the bankrupt, which indebtedness was paid to the bankrupt on August 24, in two checks. The smaller check was deposited on the 25th and was held to have been dissipated. The larger check was deposited on the 24th, and claimant asserted that if the proceeds of his stock were in the larger check it went out in the check used to pay off a specified secured loan on that day, and that he should be entitled to a lien on the collateral released by this payment. The federal courts have always held that if trust funds could be traced into payment of a secured loan, the *cestui* would have a lien on the security thus released, just as he would have on any other investment made with the trust moneys. However, the Circuit Court of Appeals denied the claimant's contention on two grounds: First, he had not shown that the larger check in which he claimed his funds were included had been deposited in the bank prior to the payment of this particular secured loan, or any other secured loan; and second, that even if the so called larger check had been deposited before the payment of the secured loan, the claimant had produced no evidence that the trust moneys included in that larger check had been appropriated to pay off this particular

loan. In other words, the Circuit Court of Appeals refused to find that, merely because trust moneys were in an account the trustee, the *cestui*, could claim any investment made with funds from that account. This decision was affirmed by the United States Supreme Court in *Schuyler v. Littlefield*, *supra*, the Supreme Court saying that not only did the record fail to show when the larger check was deposited on the 24th, but

“* * * it also fails to show with the requisite certainty the particular uses made by Brown & Co. of that money. The banking transactions on August 24th involved several millions of dollars * * *. Payments to the bank were made on account of notes, some of which represented loans appearing in the deposit account and others represented loans which had not been so entered. Some of the loans were secured and others were unsecured, and whether the money received from Miller (which included the trust fund of \$9,600) was used to pay the secured or unsecured loans does not appear with certainty. * * *

“They were practically asserting title to \$9,600, said to have been traced into stock in the possession of the trustee. Like all other persons similarly situated, they were under the burden of proving their title. If they were unable to carry the burden of identifying the fund as representing the proceeds of their Interborough stock, their claim must fail. If their evidence left the matter of identification in doubt, the doubt must be resolved in favor of the trustee, who represents all of the creditors of Brown & Company, some of whom appear to have suffered in the same way. Like them, the appellants must be remitted to the general fund.” *Schuyler v. Littlefield*, 232 U. S. 707, 713.

A careful reading of this case as it proceeded through the courts shows that there was no failure to identify the particular secured loan which it was alleged was paid with a check on the commingled account on August 24th. The Circuit Court of Appeals for the Second Circuit and the United States Supreme Court above held, however, that in addition to the failure of claimant to show that his moneys were in the account, he also failed to show whether the trust moneys went out in checks to pay secured loans (investments) or checks to pay unsecured loans (dissipation).

In the present case, Universal produced no evidence that its funds, if in that account, were specifically and expressly appropriated to any particular investment as distinguished from the countless checks which went out of the account to pay indebtedness on the part of Richfield. It is respectfully submitted that without such evidence of appropriation Universal has completely failed in tracing its funds into properties in the hands of the Receiver.

Conclusion.

In the instant case the only direct evidence of tracing was that on particular days checks were drawn on the Universal bank accounts and deposited in the Richfield general account. Whether Richfield was a debtor or trustee for these funds was a question not entirely free from doubt at the trial of Universal's claim, but we are accepting the findings of the Master in the trial court that it was a trust relationship. Based on this single

fact, the Court first presumes that regardless of the fact that on the average more money went through the Richfield account every week than the total amount of the Universal funds involved, the Universal funds would remain in the account to the extent of the low balance of that account. Second, because the means of ascertaining the low balance have failed, the Court presumes that the low balance did not fall below the overnight balances. Whether this is called "*prima facie* evidence" or placing the burden of proof on the Receiver, it is in essence dispensing with proof. Finally, the Court presumes that any investment made out of the account during the time that the twice presumed trust funds were in it were made with trust moneys. It is respectfully submitted that it must be apparent that granting a lien to Universal under such a series of presumptions is merely an improper preference under the guise of "tracing". As said of a *cestui* in the case of *In re A. O. Brown & Co.* (C. C. A. 2, 1912), 193 Fed. 30, 32, "*He cannot trace his money by a mere succession of presumptions.*"

We should not lose sight of the fact that the federal court took over these assets of Richfield to prevent preferences by attachment, taking of possession, recording of judgments, or otherwise. The principal purpose of the proceeding was to insure an equality of distribution among all claimants against an estate which was not sufficient to pay them all in full. We submit that the Court should not permit sympathy for the hardships of one claimant to blind it to the meritorious claims of six thousand other claimants who have submitted their rights to the federal courts, all of whom had tremendous hardships thrust upon them by this gigantic industrial failure.

In carrying out the principles of equity receiverships, it should be borne in mind that the authorities establish the principle that in cases of doubt claimants should be kept on a basis of equality rather than the chance taken of giving to one claimant property which is not his own, at the expense of the rest. In the last analysis equality is the highest equity. Mr. Faries says in the conclusion of his brief *amicus curiae*, that the principles here contended for resolve all doubt in favor of the wrongdoer Richfield and the trustee of its bond indenture. Rather, they resolve certain doubts in favor of the Receiver representing the thousands of claimants against the estate. Both this Court and the United States Supreme Court have heretofore ruled that all such doubts must be resolved in favor of the Receiver.

Titlow v. McCormick (C. C. A. 9, 1916), 236 Fed. 209, 211;

Schuyler v. Littlefield, 232 U. S. 707, 713; 58 L. Ed. 806, 809.

Respectfully submitted,

HENRY F. PRINCE,

HOMER D. CROTTY,

HERBERT F. STURDY,

DAVID P. EVANS,

GIBSON, DUNN & CRUTCHER,

By HENRY F. PRINCE,

634 South Spring St., Los Angeles, California,

*Solicitors for Appellee, William C. McDuffie, as Receiver
of Richfield Oil Company of California.*

The undersigned solicitors and counsel for the above named Appellee, William C. McDuffie as Receiver of Richfield Oil Company of California, do hereby certify that the foregoing Petition for Rehearing is, in our judgment, well founded, and that it is not interposed for delay.

HENRY F. PRINCE,

HOMER D. CROTTY,

HERBERT F. STURDY,

DAVID P. EVANS,

*Solicitors for Appellee, William C. McDuffie as Receiver
of Richfield Oil Company of California.*

12

**In the United States
Circuit Court of Appeals
For the Ninth Circuit.**

7012

THE REPUBLIC SUPPLY COMPANY OF CALIFORNIA,
a corporation, Complainant,

vs.

RICHFIELD OIL COMPANY OF CALIFORNIA, a corporation,
Defendant.

SECURITY-FIRST NATIONAL BANK OF LOS ANGELES, as Trustee, **GEORGE ARMSBY, F. S. BAER, HARRY J. BAUER, STANTON GRIFFIS, ROBERT E. HUNTER** and **ALBERT E. VAN COURT,** known and designated as Richfield Bondholders' Committee,

Appellants and Cross-Appellees,

vs.

UNIVERSAL CONSOLIDATED OIL COMPANY, a California corporation,

Intervenor, Appellee and Cross-Appellant,

THE CHASE NATIONAL BANK OF THE CITY OF NEW YORK, BANK OF AMERICA, a corporation, **PAN AMERICAN PETROLEUM COMPANY,** a corporation, **WILLIAM C. McDUFFIE,** as

(Continued on Inside Cover.)

Reply of David R. Faries, as Amicus Curiae in Behalf of Universal Consolidated Oil Company, to Petitions for Rehearing of Appellants and Cross-Appellees Security-First National Bank of Los Angeles, as Trustee, et al., and William C. McDuffie, as Receiver of Richfield Oil Company of California.

Receiver for Pan American Petroleum Company, a corporation, RICHFIELD OIL COMPANY OF CALIFORNIA, a corporation, UNITED STATES OF AMERICA, THE REPUBLIC SUPPLY COMPANY OF CALIFORNIA, a corporation, CITIES SERVICE COMPANY, a corporation, ROBERT C. ADAMS, THOMAS B. EASTLAND, EDWARD F. HAYES, and RICHARD W. MILLAR, known and designated as Pan American Bondholders' Committee, G. PARKER TOMS, ROBERT C. ADAMS, F. S. BAER, ROBERT E. HUNTER, HENRY S. McKEE and RICHARD W. MILLAR, known and designated as Richfield Pan American Reorganization Committee, WILLIAM C. McDUFFIE, as Receiver of Richfield Oil Company of California, SECURITY-FIRST NATIONAL BANK OF LOS ANGELES, a national banking association, PACIFIC AMERICAN COMPANY, a corporation, AMERICAN COMPANY, a corporation, MANUFACTURERS TRUST COMPANY OF NEW YORK, a corporation, CITIZENS NATIONAL TRUST & SAVINGS BANK OF LOS ANGELES, a national banking association, FIRST NATIONAL BANK AND TRUST COMPANY OF SEATTLE, a national banking association, CONTINENTAL ILLINOIS BANK AND TRUST COMPANY, a corporation, THE FIRST NATIONAL BANK OF CHICAGO, a national banking association, CHEMICAL NATIONAL BANK AND TRUST COMPANY, a national banking association, and CALIFORNIA BANK, a corporation, M. W. LOWERY, HENRY S. McKEE, O. C. FIELD, R. R. TEMPLETON, known and designated as Richfield Unsecured Creditors' Committee,

Appellees.

DAVID R. FARIES,

Subway Terminal Bldg. 417 S. Hill St., L. A.,

Amicus Curiae in Behalf of Universal Consolidated Oil Company.

DON F. TYLER,

LEONARD S. JANOFSKY,

Of Counsel.

TOPICAL INDEX

	PAGE
Introduction	4
The two principal points presented by this case.....	5
The proof of Universal's prima facie case.....	7
The equities of this case.....	18
Conclusion	21

TABLE OF AUTHORITIES CITED.

CASES.	PAGE
A. D. Matthews' Sons, Inc., In re, 238 Fed. 785.....	12
82 A. L. R. 160.....	6
82 A. L. R. at page 205.....	9
American Surety Co. v. Jackson, 24 Fed. (2) 768.....	8, 9
Blumfeld v. Union Nat. Bank, 38 Fed. (2) 455.....	17
Bogana and Williams, In re, 76 Fed. (2) 950.....	13, 17
Borman v. Sullivan, 77 Fed. (2) 342	16
Brennan v. Tillinghast, 201 Fed. 609	5
Brown, In re, 193 Fed. 24.....	13
Brunsing, Tolle & Postel, In re, 169 Fed. 668.....	10
Central National Bank v. Conn. Mutual Life Insurance Co., 104 U. S. 54, 26 L. Ed. 693.....	15
Connolly v. Lang, 68 Fed. (2) 119.....	15
Cook v. Elliott, 73 Fed. (2) 916.....	12
Elmer v. Kemp, 67 Fed. (2) 948.....	6
Fiman v. State of South Dakota, 29 F. (2) 776.....	21
First National Bank of Princeton v. Littlefield, 226 U. S. 110....	13
First Nat. Bank of St. Petersburg v. City of Miami, 69 Fed. (2) 346	13
Hanover Nat. Bank of N. Y. v. Thomas, 217 Ala. 494, 117 So. 42	15
Harmer v. Rendleman, 64 Fed. (2) 442.....	12
Harry E. Jones, Inc. v. Kemp, 74 Fed. (2) 623.....	20
J. M. Acheson Co., In re, 170 Fed. 427.....	12
Kershaw v. Jenkins, 71 Fed. (2) 647.....	13
Lathrop v. Bampton, 31 Cal. 17.....	10
Lucas County v. Jamison, 170 Fed. 338.....	11

	PAGE
Marshburn v. Williams, 15 Fed. (2) 589.....	14
Merchants & Farmers Bank v. Austin, 48 Fed. 25.....	10
Multnomah County v. Oregon Nat. Bank, 61 Fed. 912.....	10
Nixon State Bank v. First State Bank of Bridgeport, 180 Ala. 291, 60 So. 868.....	14
Oatway, In re, 2 Ch. D. 356.....	5, 6
People v. Cal. Safe Deposit etc. Co., 175 Cal. 756.....	6
Poole v. Elliott, 76 Fed. (2) 772.....	12
Potorff v. Key, 67 Fed. (2) 833.....	9
Schunaker v. Harriett, 52 Fed. (2) 817.....	14
Schuyler v. Littlefield, 232 U. S. 707, 58 L. Ed. 806.....	11, 13
Slater v. Oriental Mills, 18 R. I. 352, 27 Atl. 443.....	9
Stilson v. First State Bank, 149 Ia. 662; 129 N. W. 70.....	11
St. Louis & S. F. R. R. v. Spiller, 274 U. S. 304, 71 L. Ed. 1060	16, 17
Swan v. Children's Home Society of West Virginia, 67 Fed. (2) 84, Cert. denied 290 U. S. 704, 78 L. Ed. 605.....	9
Texas & Pac. Ry. Co. v. Potorff, Receiver, 291 U. S. 245, 78 L. Ed. 777	9, 12
The application of In re Oatway.....	6
Titlow v. McCormick, 236 Fed. 209.....	12
United States v. Pan American Petroleum Co., 55 Fed. (2) 753	20
Wisdom v. Keen, 69 Fed. (2) 349.....	9

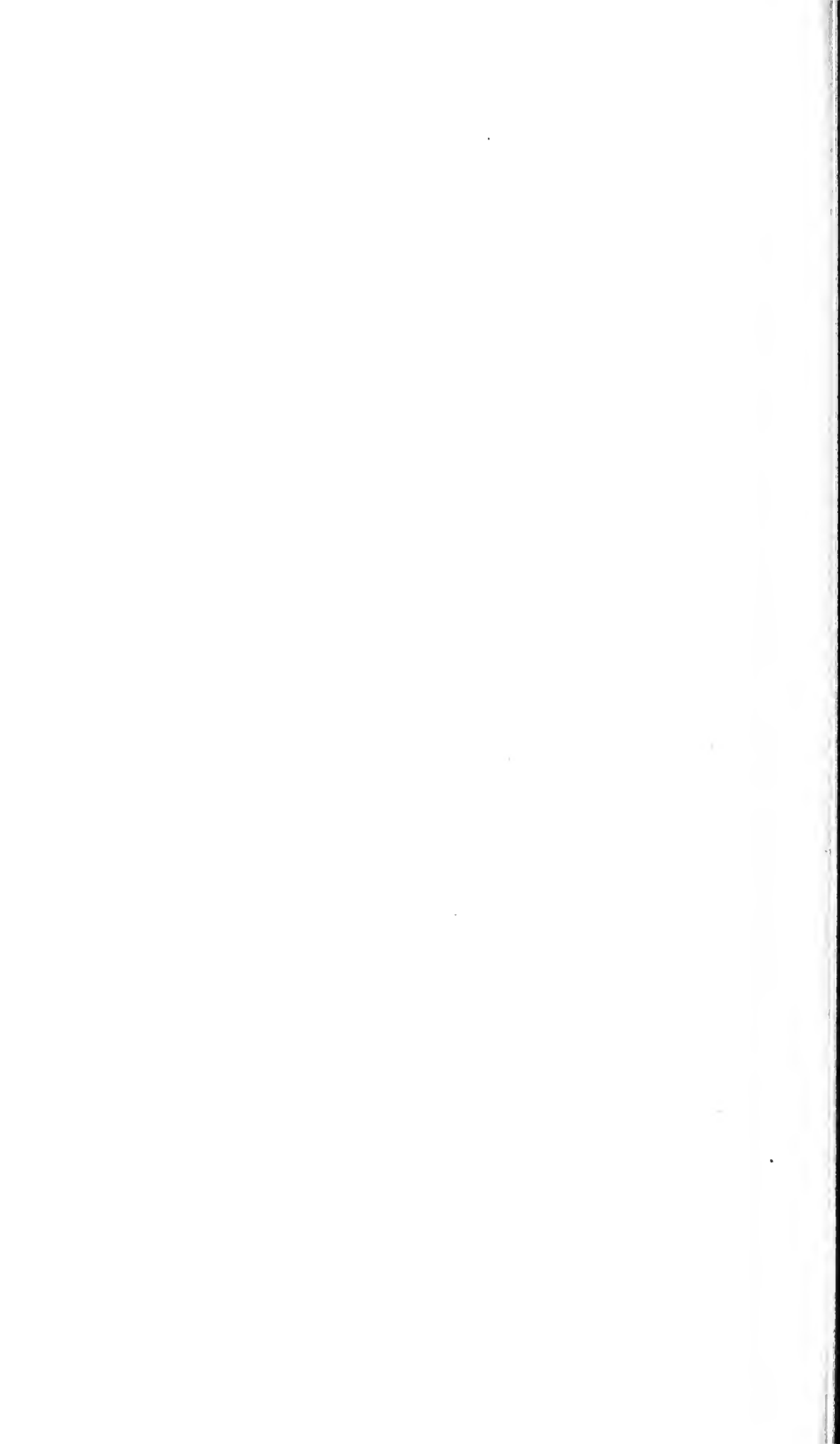

In the United States
Circuit Court of Appeals

For the Ninth Circuit.

THE REPUBLIC SUPPLY COMPANY OF CALIFORNIA,
a corporation,

Complainant,

vs.

RICHFIELD OIL COMPANY OF CALIFORNIA, a corporation,
Defendant.

SECURITY-FIRST NATIONAL BANK OF LOS ANGELES, as Trustee, GEORGE ARMSBY, F. S. BAER, HARRY J. BAUER, STANTON GRIFFIS, ROBERT E. HUNTER and ALBERT E. VAN COURT, known and designated as Richfield Bondholders' Committee,

Appellants and Cross-Appellees,

vs.

UNIVERSAL CONSOLIDATED OIL COMPANY, a California corporation,

Intervenor, Appellee and Cross-Appellant,

THE CHASE NATIONAL BANK OF THE CITY OF NEW YORK, BANK OF AMERICA, a corporation, PAN AMERICAN PETROLEUM COMPANY, a corporation, WILLIAM C. McDUFFIE, as Receiver for Pan American Petroleum Company, a corporation, RICHFIELD OIL COMPANY OF CALIFORNIA, a corporation, UNITED STATES OF AMERICA, THE REPUBLIC SUPPLY COMPANY OF CALIFORNIA, a corporation, CITIES SERVICE COMPANY, a corporation, ROBERT C. ADAMS, THOMAS B. EASTLAND, EDWARD F. HAYES, and RICHARD W. MILLAR, known and designated as Pan American Bondholders' Committee, G. PARKER TOMS, ROBERT C. ADAMS, F. S. BAER, ROBERT E. HUNTER, HENRY S. MCKEE and RICHARD W. MILLAR, known and designated as Richfield Pan American Reorganization Committee, WILLIAM C. McDUFFIE, as Receiver of Richfield Oil Company of California, SECURITY-FIRST NATIONAL BANK OF LOS ANGELES, a national banking association, PACIFIC AMERICAN COMPANY, a corporation, AMERICAN COMPANY, a corporation, MANUFACTURERS TRUST COMPANY OF NEW YORK, a corporation, CITIZENS NATIONAL TRUST & SAVINGS BANK OF LOS ANGELES, a national banking association, FIRST NATIONAL BANK AND TRUST COMPANY OF SEATTLE, a national banking association, CONTINENTAL ILLINOIS BANK AND TRUST COMPANY, a corporation, THE FIRST NATIONAL BANK OF CHICAGO, a national banking association, CHEMICAL NATIONAL BANK AND TRUST COMPANY, a national banking association, and CALIFORNIA BANK, a corporation, M. W. LOWERY, HENRY S. MCKEE, O. C. FIELD, R. R. TEMPLETON, known and designated as Richfield Unsecured Creditors' Committee,

Appellees.

Reply of David R. Faries, as Amicus Curiae in Behalf of Universal Consolidated Oil Company, to Petitions for Rehearing of Appellants and Cross-Appellees Security-First National Bank of Los Angeles, as Trustee, et al., and William C. McDuffie, as Receiver of Richfield Oil Company of California.

Introduction

To the Honorable United States Circuit Court of Appeals for the Ninth Circuit and the Judges thereof:

This reply is filed by David R. Faries, counsel for minority stockholders of Universal Consolidated Oil Company, as *amicus curiae* in behalf of that company pursuant to telegraphic request on October 9th for leave so to do and the answer of the Clerk of this Honorable Court suggesting that this reply be presented within ten days from that date. When this request was made the undersigned counsel had received a copy of the petition for rehearing of the appellants and cross-appellees, Security-First National Bank of Los Angeles, et al., (hereinafter referred to as Security Bank). Thereafter, we received a copy of the petition for rehearing filed by William C. McDuffie as Receiver of Richfield Oil Company of California, (hereinafter referred to as the Receiver). We thereupon dispatched another telegram to the Clerk of this Honorable Court informing him that we were filing a reply brief and protesting against this belated entrance of the Receiver into this case. This protest we now renew.

The Receiver's position herein is, we submit, anomalous. By reason of the machinations of the former officers of

the Richfield he holds 52% of the stock, a controlling interest, in Universal. He is on both sides of the fence. As Receiver he seeks to defeat a claim in which he owns a majority interest. He did not file a brief nor appear at the oral argument herein. Now, at the end of the time for filing a petition for rehearing, he appears with a 94 page document asking for a reconsideration of a matter which he has allowed to proceed to hearing, submission and the filing of an opinion. We cannot see after diligent examination that this weighty document contains a single new point, and we respectfully protest against the late intrusion into this case of one who should stand in a neutral position.

The Two Principal Points Presented by This Case.

At the outset we should probably point out that there were two main phases of this case discussed by this Honorable Court, (1) the application of the principle of *In re Oatway*, (1903) 2 Ch. D. 356, as adopted in the Federal Courts by the case of *Brennan v. Tillinghast*, 201 Fed. 609 (C. C. A. 6) (1913), and other Federal cases cited upon pages 4 and 5 of the opinion, and (2) the consideration of the evidence establishing the *prima facie* lowest intermediate balance. The petition of the Security Bank seeks a rehearing only upon this latter phase of the case. The wordy petition of the Receiver does, however, contain the complaint that the theory of *In re Oatway* is wrong. (Receiver's Petition p. 81 to 91, incl.)

The Application of *In re Oatway*.

We feel that the law is so clearly established upon this point and the matter so thoroughly considered by this Honorable Court that little mention need be made of the matter here. The Receiver claims that both the rule in *Hallett's* case and its logical extension in *In re Oatway* do not apply in the State of California when a trustee *ex maleficio* is involved. What confusion there is in the state law is a result of taking the so-called Hallett presumption literally and considering it as based upon the presumption that a person is innocent of crime or wrong. (Receiver's petition, page 68, *People v. Cal. Safe Deposit etc. Co.*, 175 Cal. 756 (1917)). This naturally has led to the confusing result that when a trustee *ex maleficio* was involved the California Court thought it could not be presumed that he would act innocently with respect to the *cestui's* funds. In other words, certain of the California cases have overlooked the facts that have often been pointed out by the Federal Courts, namely that (a) the Hallett presumption is not to be used as a shield for a wrongdoer, and (b) that the *cestui* is entitled to what is left of the mixed fund or its product not because of any intent of the wrongdoer but because the wrongdoer, whatever his intent, should not be allowed to deprive the claimant of his lien on the mixed fund or its product. (See: 82 A. L. R. at page 160.)

This bit of reasoning in the California law is dignified by the Receiver by being called a rule of property and he urges it upon us as binding on the Federal Courts. In this connection we wish merely to again call the attention of this Honorable Court to the case of *Elmer v. Kemp*, 67 Fed. (2) 948, 952 (C. C. A. 9) (1933), cited on page 44 of our *Amicus Curiae* brief. There this Hon-

orable Court had before it the attempt of the Receiver of Guaranty Building and Loan Association to trace funds misappropriated by Gilbert Beesemyer into the assets of his insolvent *alter ego* The Elmer Company. This Honorable Court there directly considered whether it should be bound by state decisions to the point of not being able to express its own views of equitable jurisprudence and dismissed the contention in the following language:

“Moreover, in a federal court of equity, we must decide cases in accordance with our view of the general principles of equity jurisprudence. *Kuhn v. Fairmont Coal Co.*, 215 U. S. 349, 363, 30 S Ct. 140, 54 L. Ed. 228; *Russell v. Southard*, 12 How. 139, 13 L. Ed. 927; *Neves v. Scott*, 13 How. 268, 14 L. Ed. 140. *The decisions of the particular state in which the cause of action arose are to be followed only in so far as they conform to established principles of equitable jurisprudence.*” (Italics ours.) (67 F. (2) at 952.)

See also cases cited on page 25 of the brief of Security Bank filed before the hearing.

The Proof of Universal's Prima Facie Case.

This brings us to a consideration of the second phase of this case, that is, the sufficiency of the evidence offered to establish the lowest intermediate balances of the Richfield bank account. Much is said in both petitions for rehearing about the burden of proof being always upon the claimant seeking to establish a trust and a number of cases containing such language have been cited.

We have at no time contended that this is not the rule. There is likewise no doubt, from the reading of the

opinion, that this Honorable Court recognizes it as the rule. We do contend, however, that in this case the evidence of the daily closing balances in the Richfield account when uncontradicted by any other competent evidence clearly satisfied this burden of proof. In every case, whether it be for the establishment of a trust lien, or any other cause of action, there comes a time when the party with the burden of proof either has, or has not, established his *prima facie* case. If the *prima facie* case is established, the duty then devolves upon the opposing party to introduce evidence controverting that showing. We believe that an analysis of both petitions for rehearing will show that their cases support no other proposition than the one just stated. This proposition is the basis for the opinion of this Honorable Court with respect to this phase of the case, and is the correct and unimpeachable rule as evidenced by the well reasoned decision of this Honorable Court in *American Surety Co. v. Jackson*, 24 Fed. (2) 768 (C. C. A. 9) (1928) where it was said by Circuit Judge Rudkin:

“In *Smith v. Mottley*, *supra*, the Circuit Court of Appeals for the Sixth Circuit held that the burden of showing that his property had been wrongfully mingled in the mass of the property of the wrongdoer was on the owner who sought to follow it, but, when this was done, the burden shifted to the wrongdoer to show that the money or property had passed out of his hands, and that his trustee in bankruptcy stood in the same position. This ruling was reaffirmed in *Board of Com'rs. v. Strawn*.” (24 Fed. (2) at 770.)

Additional cases on this point are collected in 82 A. L. R. at page 205. The *American Surety* case and many of the others appearing in the A. L. R. note are cited in the opinion of this Honorable Court. It cannot possibly be conceived therefore why a further hearing should be granted upon a point already thoroughly discussed and considered.

We now pause to briefly examine the cases cited in the petitions to see if anything new is presented.

In the following cases appearing on pages 11-14, inclusive, of the Receiver's petition the *cestui que* trust clearly failed to establish a *prima facie* case.

Pottorff v. Key, 67 Fed. (2) 833 (C. C. A. 5) (1933) (Evidence traced trust res, not into the hands of the receiver, but *elsewhere*.) (67 Fed. (2) at 834);

Texas & Pac. Ry. Co. v. Pottorff, Receiver, 291 U. S. 245, 78 L. Ed. 777 (1934) (*Claimant failed to even establish a trust relation, to say nothing of an identifiable res.*) (78 L. Ed. at 786);

Slater v. Oriental Mills, 18 R. I. 352, 27 Atl. 443 (1893) (Even *on demurrer* it appeared here that the *cestui's* property had been *dissipated*.) (27 Atl. at 443);

Wisdom v. Keen, 69 Fed. (2) 349 (C. C. A. 5) (1934) (*No trust res ever existed.* "But no actual cash was segregated and specially deposited.") (69 Fed. (2) at 349.) ("Here the bank agreed to segregate a *trust res* but never did it.") (69 Fed. (2) at 350.)

Swan v. Children's Home Society of West Virginia, 67 F. (2) 84 (C. C. A. 4) (1933), Cert.

denied, 290 U. S. 70⁴, 78 L. Ed. 605) "*It positively appears* that no fund which has come into the hands of the reciver could have been augmented as a result of the deposit here in question . . . the check to the bank resulted in a *mere shifting* of credits and added nothing whatever to its assets.") (67 Fed. (2) at 88).

Multnomah County v. Oregon Nat. Bank, 61 Fed. 912 (C. C. D. Ore.) (1894) ("*It does not appear* that the money for distribution includes any part of that belonging to the involuntary creditor. If this did appear, the lien of such creditor would attach, and he would have his preference.") (61 Fed. at 914).

In re Brunsing, Tolle & Postel, 169 Fed. 668; (D. C. Cal.) (1909) ("It will be observed that the referee does not find, specifically, that the bankrupt used \$265.65 of Peterson's deposit to pay for merchandise which went into the general stock of merchandise carried by the bankrupt; nor is there any finding that such merchandise, or its proceeds, came into the hands of the trustee.") (169 Fed. at 668).

Lathrop v. Bampton, 31 Cal. 17 (1866) ("It is true the Court finds generally that he mixed the trust money with his own and used both in his general business expenditures and investments, but *the Court does not find, nor does the complaint allege*, that any of his estate now in the custody of the defendant is the fruit or product of those investments.") (31 Cal. at 22).

Merchants & Farmers Bank v. Austin, 48 Fed. 25; (C. C. N. D. Ala.) (1891) (" . . . but neither he nor any other witness says that

these checks were actually paid to the defendant bank. . . . But conceding that the money was collected and put into the general cash of the defendant bank, then what does the evidence show as to what became of it? . . . *There is no evidence in the records tracing any of the complainant's money or its proceeds into the hands of Receiver Austin.*") (48 Fed. at 27).

Lucas County v. Jamison, 170 Fed. 338; (C. C. S. D. Ia.) (1908) (*Funds completely dissipated. "If the alleged trust funds have been dissipated then the cases are at an end; and with but one single exception such are the facts."*) (170 Fed. at 348).

Stilson v. First State Bank, 149 Ia. 662; 129 N. W. 70 (1910) (Complainant merely established constructive trust based on fraud, *wholly failed to maintain burden of proof*) (129 N. W. at 72, 73).

The distinction drawn above between the cases cited on pages 10-14, inclusive, of the Receiver's petition and the principal case applies with equal force to the additional cases cited by the Receiver on pages 15 and 16 of his petition which he characterizes as being clearly at variance with the decision in the instant case. (Receiver's petition page 16.) Two of the following cases are also cited by the Security Bank on page 5 of its petition:

Schuyler v. Littlefield, 232 U. S. 707, 58 L. Ed. 806, (1914) (This case has been thoroughly considered by this Honorable Court and was discussed on pages 39 and 40 of our *Amicus Curiae* brief. This case was also cited by the Security Bank);

Texas & Pac. Ry. Co. v. Pottorff, Receiver, 291 U. S. 245, 78 L. Ed. 777 (1934) (Distinguished *supra*);

Titlow v. McCormick, 236 Fed. 209, (C. C. A. 9) (1916) (No augmentation) (236 Fed. at 211), (and where there was augmentation the funds were completely dissipated) (236 Fed. 212, 214);

In re J. M. Acheson Co., 170 Fed. 427 (C. C. A. 9) (1909) (This case is discussed on page 15 of our *Amicus Curiae* brief);

Pooler v. Elliott, 76 Fed. (2) 772 (C. C. A. 4) (1935) (“Here there was neither allegation nor proof tracing the proceeds of the deposits by petitioner into the hands of the receivers;”) (76 Fed. (2d) at 774);

In re A. D. Matthews' Sons, Inc., 238 Fed. 785 (C. C. A. 2) (1916) (Part of the funds sought to be impressed with a trust wholly dissipated, as to remainder merely a showing that the *trust res* was “somewhere” in the trustee’s estate. Also cited on page 5 of the Security Bank petition) (238 Fed. at 786, 787);

Cook v. Elliott, 73 Fed. (2) 916 (C. C. A. 4) (1934) (Held merely that a trust relation was established. No evidence whatever re tracing and that question expressly left open) (73 Fed. (2) at 918);

Harmer v. Rendleman, 64 Fed. (2) 422 (C. C. A. 4) (1933) (No augmentation. “. . . plaintiff was not credited with the principal amount of any of the securities; . . . There is nothing to show what became of the securities.” (64 Fed. (2) at 423).

First Nat. Bk. of St. Petersburg v. City of Miami, 69 Fed. (2) 346 (C. C. A. 5) (1934) (Clearly no augmentation, payment merely by check. "As proven, no sum whatever was collected and held for plaintiff. . . ." (69 Fed. (2) at 347) "Here, as there, there was 'but a shifting of liability.'" (69 Fed. (2) at 348).

Kershaw v. Jenkins, 71 Fed. (2) 647 (C. C. A. 10) (1934) "The check was charged to his account, but no new money was brought into the bank from an outside source. The transaction was merely one of shifting credits on the books of the bank, and that does not constitute augmentation of assets." (71 Fed. at 649).

In re Bogena & Williams, 76 Fed. (2) 950 (C. C. A. 7) (1935) (Here there was a complete failure of proof as to the condition of the bank account in question from February 11, 1933 to March 11, 1933.) (76 Fed. (2) at 954).

The Receiver's petition appears to reach the apex of its argument on this point when it states on page 29 thereof that the unanimous authority of five decisions passing directly on the point, two of them affirmed by the United States Supreme Court, are opposed to the decision rendered by this Honorable Court. These five decisions are cited on page 41 of the Receiver's petition. Two of said cases, also cited in the Security Bank's petition (p. 5), namely, *In re Brown*, 193 Fed. 24 (C. C. A. 2) (1912) affirmed without mention of this particular point in *First National Bank of Princeton v. Littlefield*, 226 U. S. 110 (1912) and *Schuyler v. Littlefield*, 232 U. S. 707, 58 L. Ed. 806 (1914) were thoroughly analyzed and distinguished from the case at bar in the brief *Amicus*

Curiae (pp. 24, 25, 39, 40) and have already been considered by this Honorable Court. Therefore, we shall not again burden the court with a discussion of those cases.

There remain, therefore, to be considered only three of the five decisions alleged to be directly at variance with the decision of this court.

The first case is *Marshburn v. Williams*, 15 Fed. (2) 589, (D. C. N. C.) (1926) cited on page 41 of Receiver's petition. We respectfully submit that that case is properly distinguished from the principal case upon the ground that there there was no augmentation of the assets passing into the hands of the Receiver. This distinction does not perhaps clearly appear from a mere reading of the opinion in the *Marshburn* case written by Circuit Judge Parker when sitting in the District Court. It does however clearly appear when Circuit Judge Parker while sitting in the Circuit Court of Appeals for the Fourth Circuit writes the opinion of *Schumaker v. Harriett*, 52 Fed. (2) 817 (1931) and says:

“We have examined with care the cases relied upon by the receiver, particularly the cases of *First National Bank of Ventura v. Williams* (D. C.) 15 F. (2d) 585, and *Marshburn v. Williams* (D. C.) 15 F. (2d) 589; but we do not think that they are in point. In both of the cases cited the court was of the opinion that, *under the peculiar facts there existing*, there was no augmentation of the assets which passed into the hands of the receiver.” (52 Fed. (2) at 820.)

The second new case cited by the Receiver is *Nixon State Bank v. First State Bank of Bridgeport*, 180 Ala. 291, 60 So. 868 (1912). The ruling in that case is ex-

plained by the fact that the Supreme Court of Alabama does not follow, and in fact, in the case of *Hanover Nat. Bank of N. Y. v. Thomas*, 217 Ala. 494, 117 So. 42 (1928) expressly repudiated, the doctrine established in *In re Hallett's* case and adopted by the Federal Courts in *Central National Bank v. Conn. Mutual Life Insurance Co.*, (104 U. S. 54, 26 L. Ed. 693):

“The utterance immediately following the above quotation from the opinion in *J. Allen Smith & Co. v. Montgomery, as State Supt. of Banks, supra*, to-wit, ‘and proof that he received or took over a fund into which the appellants’ money had been placed or with which it had been commingled will not suffice.’ *was intended to indicate that this court was not in accord with the doctrine announced in Re Hallett*, 13 Ch. Div. 696, that proof that the balance of the fund into which the claimant’s money entered had not been reduced below the amount of the claim asserted would not meet the requirements of the law, but that the claimant must go further and show, as averred here, that the claimant’s property remained in the fund into which it had been traced, and, thus commingled, passed into the hands of the respondent.” (117 So. at 45.)

The third case cited by the Receiver not yet considered by this court is *Connolly v. Lang*, 68 Fed. (2) 119 (C. C. A. 7) (1933). It is patent from the following quotation therefrom that the evidence of the *cestui* there introduced failed to establish a *prima facie* case and was in no respect anywhere near as strong as the evidence introduced by Universal in the principal case:

“While it is found that at the time the Bank was closed it had on hand more than the amount of ap-

pellee's claim in cash, which appellant received, yet that does not necessarily mean that that sum included any part of appellee's money. *The cash balance of the Bank, if any, at the beginning of business on June 22, 1932, is not disclosed, nor are the deposits and withdrawals shown for that day.*" (68 Fed. (2) at 201.) (Italics ours.)

There are two additional cases cited by the Receiver, one of which is also cited by the Security Bank, which we pause for a moment to consider. The first is *Borman v. Sullivan*, 77 Fed. (2) 342 (C. C. A. 7) (1935). By the Receiver's own admission the only language in the *Borman* case applicable to the principal case is mere dictum (Receiver's petition page 42). The case only holds that upon the facts proved no trust was created. However, even the dictum relied upon by the Receiver is not opposed to our contentions because, as is seen from the following quotation, it discloses that the evidence introduced by the *cestui* in order to trace the alleged trust funds was not nearly as clear as that introduced by Universal in the present case:

"The record does not disclose the status of the bank's currency account at any time between the time at which it is claimed the bank received the money in trust and the time it closed." (77 Fed. (2) at 344.)

It is to be noted that the court in *Borman v. Sullivan*, *supra*, cited and relied upon only one case, namely, *St. Louis & S. F. R. R. v. Spiller*, 274 U. S. 304, 71 L. Ed. 1060 (1927) in support of its dictum. A careful reading and analysis of that case discloses that the funds upon which a trust was there sought to be imposed were

kept in *several banks* and had *in the aggregate* a balance in excess of the fund claimed by claimant. That is, although in the aggregate the several banks always contained an amount equal to the funds sought to be traced, no evidence whatever was introduced to show that as to *any one* of the several banks containing the deposits in question the funds in *that bank* had not at some time been wholly dissipated. The distinction which we have drawn between *St Louis & S. F. R. R. v. Spiller, supra*, and the present case is made conclusively by the case of *In re Bogana and Williams*, 76 Fed. (2) 950, in which case the Seventh Circuit Court of Appeals on pages 954 and 955 of its opinion expressly distinguishes the *Spiller* case upon the grounds we have suggested.

The remaining case to be considered is *Blumenfeld v. Union Nat. Bank*, 38 Fed. (2) 455 (C. C. A. 10) (1930) cited on page 5 of the petition for the Security Bank and pages 29 and 30 of the petition for the Receiver. We again submit that the evidence in that case is in nowise comparable to the evidence here introduced by Universal. This fact is self evident from the opinion of Circuit Judge Cotteral:

“In the instant case there is a *dearth of evidence* to show what amount of money remained in the Beloit bank through the period dating from the time it acquired the trust fund on July 28, 1922, to the date the receiver took charge on November 5, 1923.” (38 Fed. (2) at 457.)

It will thus be seen that the language of each of these cases must be considered directly with its own peculiar factual set-up. This is inevitably true when we deal with the sufficiency of the evidence to establish a *prima facie* case.

The new cases cited by the Receiver and by the Security Bank fail to in any way shake the opinion of this Honorable Court for reasons peculiar to themselves. There was either a failure to establish a trust; a failure to prove an augmentation of the assets or a failure to show the condition of the bank account for several days.

The Equities of This Case.

A good deal is said in both petitions about Universal and its minority stockholders being treated better than they deserve. The Security Bank hastens to say that if Universal were proceeding against Richfield alone they would have no complaint but that, "The bondholders . . . are as innocent of wrongdoing as is Universal itself." (Petition of the Security Bank, page 6). We have no doubt that this Honorable Court fully considered that matter, from a reading of the statements in its opinion (page 9) as to the relative equities. Before closing may we briefly, however, call the court's attention to page 204 of the transcript wherein the Special Master directly refutes the contention that the bondholders stand in a position equal with Universal concerning the properties subject to the trust lien:

"The trustee has not claimed any priority, but counsel for Universal have discussed the possible point, and it should perhaps be noticed. All of the payments in question out of trust funds were made after the date of the trust indenture. The interests acquired by those payments could only be regarded as included in the indenture by virtue of a clause thereof extending the lien to after-acquired interests, assuming the existence of such a clause. It is true that a bona fide purchase or encumbrancer, for value,

without notice, will be protected. (Citing cases.) But it appears to be established that an encumbrancer does not occupy that position in reference to after-acquired property, that his lien attaches in that case only to what the debtor actually acquires, and that if the latter gets nothing in fact, regardless of appearances, the former gets nothing. *Holt v. Henley*, 232 U. S. 637, 58 L. ed. 767; *Detroit Steel Co-opperage Co. v. Sistersville Brewing Co.*, 232 U. S. 712, 58 L. ed. 1166; *Fosdick v. Schall*, 99 U. S. 235, 25 L. ed. 339." (Italics ours.)

It also seems to us that complaints as to the sufficiency of Universal's showing with respect to the condition of Richfield's bank account come from the mouth of the Security Bank with very poor grace. It should not be overlooked that Security Bank as trustee of the bond indenture also received the deposits of Richfield [Tr. p. 143] and maintained a system of bookkeeping which only showed the true status of an account at the end of the day. It, by its method of bookkeeping, controlled the evidence that could be introduced.

The Receiver in his belated appearance also feels that Universal has been unduly favored and characterizes himself as the representative of some 6,000 claimants among whom "are many whose claims are based on fraud equally as reprehensible as that in the case of Universal, if not more so." (Receiver's petition, pages 9 and 10.) The record is, of course, silent upon this point and these insubstantial defrauded claimants seem to be ghosts con-

jured up by the legerdemain of counsels' artful words. In fact, in the next breath counsel for the Receiver, again without support in the record, refer to the *United States v. Pan American Petroleum* case (55 Fed. (2d) 753) where recovery of oil stolen from the Naval Petroleum Reserve was sought. Counsel failed to point out that this has no bearing here particularly in view of the fact that that case has been settled and payments pursuant thereto are now being arranged. At any rate, two wrongs do not make a right nor does the righting of one necessarily mean that the other must go without remedy. If there are other defrauded creditors of Richfield they have had the same opportunity as Universal to present their evidence and obtain a lien upon property purchased with their funds.

The decision of this Honorable Court in *Harry E. Jones, Inc. v. Kemp*, 74 Fed. (2) 623 (C. C. A. 9) (1930), cited on page 24 of the Receiver's brief is certainly not contra to the thoughts expressed here. There the funds sought to be traced had been deposited in bank accounts and completely dissipated. It was urged that the Receiver was estopped to show this dissipation, and this Honorable Court naturally refused to take that view. The Receiver there certainly had the right to show by affirmative evidence that the funds had been dissipated and the Receiver here, or the Security Bank had the same right.

It is elementary that the Receiver by virtue of his representative capacity does not thereby lift himself to

rights greater than the defaulting trustee. As has been aptly said by the Special Master [Tr. p. 199]:

“The character of proof is not changed by receivership. The receiver gets nothing more than his principal had; and he takes subject to all the equities. The marshalling of claims against the estate does not put into the estate what was not there.”

And in *Fiman v. State of South Dakota*, 29 F. (2d) 776, 781 (C. C. A. 8) (1928) the court stated:

“The receiver stands in the place of the bank, taking the assets in trust for the creditors, subject to the claims and defenses that might have been interposed against the insolvent corporation.”

Conclusion.

The rights of the Receiver and the Security Bank were then to show by affirmative evidence that the *prima facie* case of Universal was in some way incorrect. This they failed to do. It seems useless to argue, particularly in this case, that the daily closing balance was not the one which truly disclosed the status of the bank account. This Honorable Court has aptly said upon page 9 of its opinion:

“No citation of authority is necessary to support the statement that the daily closing balance is the one which reflects the actual state of the ordinary commercial bank account, and is the only one accepted and used by both bank and customer in ordinary business transactions.”

In closing, the equities of Universal are clearly predominant and the evidence of the status of the bank account plain. If there was no evidence to controvert this *prima facie* showing it is now quite late for the Security Bank and the Receiver to complain that this matter should be reheard.

Respectfully submitted,

DAVID R. FARIES,

*Amicus Curiae in Behalf of Universal Consolidated Oil
Company.*

DON F. TYLER,

LEONARD S. JANOFSKY,

Of Counsel.

In the United States
Circuit Court of Appeals
For the Ninth Circuit.

The Republic Supply Company of California, a corporation,

Complainant,

vs.

Richfield Oil Company of California, a corporation,

Defendant.

Security-First National Bank of Los Angeles, as Trustee, et al.,

Appellants and Cross-Appellees,

vs.

Universal Consolidated Oil Company, a California corporation,

Intervenor, Appellee and Cross-Appellant,

The Chase National Bank of the City of New York, et al.,

Appellees.

ANSWER TO PETITIONS FOR REHEARING.

FILED

(Continued on Inside Cover.)

OCT 24 1906

LEROY M. EDWARDS,

A. L. WEIL,

L. A. Gas & Electric Bldg., 810 S. Flower St.,
*Attorneys for Appellee and Cross-Appellant, Universal
Consolidated Oil Company.*

MARTIN J. WEIL,

O. C. SATTINGER,

Of Counsel.

TOPICAL INDEX.

PAGE

I.

The petitions for rehearing do not conform to the rules of this court 4

II.

The receiver is but an arm of the court, having custody of the property, and taking it subject to all of the liens and priorities theretofore existing to the same extent that such liens could be urged against the defunct corporation..... 5

III.

The decision herein properly determined that Universal had made out a prima facie case with the use of the closing balances 11

A. Under the facts of this case the closing balances were the only ones that could be used..... 11

B. Without any contrary evidence, the prima facie case of Universal must stand..... 15

IV.

The decision of the instant case does not contravene the decisions of the Supreme Court or Circuit Courts..... 17

V.

The doctrine of in re Oatway properly applies to this case..... 22

VI.

The decisions of the California state courts are not binding upon the federal courts insofar as they affect the tracing of trust funds. Were the California cases binding, we still submit that they are favorable to Universal's position and not to the receiver's 24

Conclusion 28

TABLE OF AUTHORITIES CITED.

CASES.	PAGE
Adams v. Champion, 79 L. Ed. (Adv. Op.) 366.....	29
American Surety Co. v. Jackson, 24 Fed. (2d) 768.....	15
Auten v. City, etc. Co., 104 Fed. 395.....	7
Bassick Mfg. Co v. Adams, etc. Corp., 54 Fed. (2d) 285.....	6
Beard v. Independent District, 88 Fed. 375.....	24, 26
Black v. Manhattan Trust Co., 213 Fed. 692.....	7
Blumenfeld v. Union, 38 Fed. (2d) 455.....	20
Bogena, In re, 76 Fed. (2d) 950.....	20
Borman v. Sullivan, 77 Fed. (2d) 342.....	19
Brennan v. Tillinghast, 201 Fed. 609.....	14, 23
Brunsing, In re, etc., 169 Fed. 668.....	19
Byrne, In re, 32 Fed. (2d) 189.....	16, 19
Byrne v. McGrath, 130 Cal. 316.....	26
Central etc. Co. v. Missouri, etc. Co., 28 Fed. (2d) 176.....	8
Central Nat'l. Bank v. Conn. Mut. Life Ins. Co., 104 U. S. 54, 26 L. Ed. 693.....	15
Clark v. Bacorn, 116 Fed. 617.....	9
Cohens v. Virginia, 6 Wheaton 265, 5 L. Ed. 257.....	21
Connolly v. Lang, 68 Fed. (2d) 199.....	18, 19
Detroit Steel Cooperage Co. v. Sistersville, 233 U. S. 712, 58 L. Ed. 1166.....	9
Elmer v. Kemp, 67 Fed. (2d) 948.....	26
Fiman v. So. Dak., 29 F. (2d) 776.....	23
First Nat'l. etc. v. City of Miami, 69 Fed. (2d) 346.....	19
First National Bank of Princeton v. Littlefield, 226 U. S. 110.....	17
Fitchie, et al. v. Brown, et al., 211 U. S. 321, 53 L. Ed. 202....	22
Fosdick v. Schall, 99 U. S. 235, 25 Law Ed. 339.....	6, 9

	PAGE
Fourth St. Nat'l. Bk. v. Yardley, 165 U. S. 634, 41 L. Ed. 855....	6
Geddes v. Reeves, etc. Co., 20 Fed. (2d) 48 (certiorari denied 275 U. S. 556).....	7
Grant v. Phoenix, etc. Co., 106 U. S. 429, 27 Law Ed. 237.....	7
Greyling Realty Corp., In re, 74 Fed. (2d) 734.....	8
Hanover Nat'l. Bank v. Thomas, 217 Ala. 494, 117 So. 42.....	21
Harmer v. Rendleman, 64 Fed. (2d) 422.....	19
Harry E. Jones, Inc. v. Kemp, 74 Fed. (2d) 623.....	10
Holt v. Henley, 232 U. S. 637, 58 L. Ed. 767.....	9
Home Trust Co. v. Miller Pet. Co., 27 Fed. (2d) 748.....	8
Jennings v. U. S. F. & G. Co., 79 L. Ed. (Adv. Op.) 355.....	14
John Deere Plow Co. v. McDavid, 137 Fed. 802.....	24, 25
Kennizon v. Kanzler, 4 Fed. (2d) 315.....	8
Kershaw v. Jenkins, 71 Fed. (2d) 647.....	19
Marine Transit Corp. v. Dreyfus, 284 U. S. 263, 76 L. Ed. 282..	22
Marshburn v. Williams, 15 Fed. (2d) 589.....	20
Matthews', etc., In re, 238 Fed. 785.....	19
Merchants, etc. v. Austin, 48 Fed. 25.....	19
Merriman v. Chicago, etc. Co., 66 Fed. 663.....	6, 25
Mitchell v. Dunn, 211 Cal. 129.....	25, 27
Mulligan, In re, 116 Fed. 715.....	19
Multnomah Co. v. Oregon, etc., 61 Fed. 912.....	19
Nicholson v. Western, etc. Co., 60 Fed. (2d) 516.....	8, 10
Nixon State Bank v. First State Bank of Bridgeport, 60 So. 868	21
Oatway, In re, 2 Ch. Div. 356.....	23
Pacat, In re, 27 F. (2d) 810.....	23
Poole v. Elliott, 75 Fed. (2d) 772.....	19

	PAGE
Porter v. Boyd, 171 Fed. 305.....	9
Pottorff v. Key, 67 Fed. (2d) 833.....	20
Primeau v. Granfield, 184 Fed. 480.....	23
Schuyler v. Littlefield, 232 U. S. 707.....	17, 18
Swan v. Children's, etc., 67 Fed. (2d) 84.....	19
Titlow v. McCormick, 236 Fed. 209.....	20
United States etc. Co. v. Missouri, etc. Co., 269 Fed. 497 (cer- tiorari denied 256 U. S. 699).....	7
Vincent National Drug Stores, Inc., 3 Fed. (2d) 504.....	8
Wisdom v. Keen, 69 Fed. (2d) 349.....	19, 26
Witherspoon v. Choctaw, etc. Co., 56 Fed. (2d) 984.....	8
Wright v. Seaboard, etc. Corp., 272 Fed. 807.....	8

No. 7812.

In the United States
Circuit Court of Appeals
For the Ninth Circuit.

The Republic Supply Company of California, a corporation,

Complainant,

vs.

Richfield Oil Company of California, a corporation,

Defendant.

Security-First National Bank of Los Angeles, as Trustee, et al.,

Appellants and Cross-Appellees,

vs.

Universal Consolidated Oil Company, a California corporation,

Intervenor, Appellee and Cross-Appellant,

The Chase National Bank of the City of New York, et al.,

Appellees.

ANSWER TO PETITIONS FOR REHEARING.

I.

**The Petitions for Rehearing Do Not Conform to the
Rules of This Court.**

(All italics are ours unless otherwise noted.)

Neither petition for rehearing conforms with the rules of the Circuit Court. The petition of the Security Bank fails to have attached thereto a certificate of counsel and for this reason alone it could be disregarded.

So far as the 94-page document filed by the Receiver is concerned, this so-called petition is in direct violation of Rule 29 of this Court. This rule provides, in part, that the petition for rehearing shall "*briefly and distinctly* state its grounds." We cannot help but feel that the Receiver's petition in reality occupies the position of a reply brief, with its attack principally directed towards *amicus curiae*, instead of occupying the name under which it is filed.

It seems quite singular that this Receiver, having full knowledge of the appeals of both Universal and Security Bank; having received copies of the briefs of the various parties prior to the submission of the case for decision; and having failed to file any assignment of errors, any appeal, or any brief, should now present himself to the Court at the *last hour* with this petition. Had counsel for the Receiver seen fit to aid this Court, they could have done so at the appropriate time by filing proper briefs and participating in the case.

The conduct of the Receiver impels one to the belief that it was apparently the Receiver's *original* view that the outcome of the litigation principally affected the lien of the Security Bank and the bondholders under the trust indenture, and that the Security Bank was competent to repre-

sent these secured creditors. Now he seeks to take the side of the Security Bank and aid that party in obtaining a *greater* lien under its trust indenture to the prejudice of Universal under its lien by operation of law.

Furthermore, the Receiver has time and time again misquoted the record of the case; in fact virtually every reference falls into this category.

Notwithstanding the undue length of the petition of the Receiver, and notwithstanding the addition of innumerable citations, it is the belief of Universal that this petition can be answered without emulating the Receiver. It might be noted at this juncture that the Receiver does not present a *single* other Federal case—not heretofore cited by some party to this proceeding in the various briefs—which bears upon the main question of the proper low balance to be used.

II.

The Receiver Is but an Arm of the Court, Having Custody of the Property, and Taking It Subject to All of the Liens and Priorities Theretofore Existing to the Same Extent That Such Liens Could Be Urged Against the Defunct Corporation.

While the Receiver states that he “holds no brief for, and in no wise champions, Richfield or its former officers,” yet it is apparent that the Receiver *does* champion the Security Bank in an attempt to aid its lien under its trust indenture.

The Receiver first contends that, as Receiver, his position is different from that of his insolvent, Richfield; and that under the maxim “Equality is the highest equity,” Universal’s whole claim should *now* be reduced to that of

a general creditor. But the Receiver never raised this question of his so-called preferred status at the trial, nor did the Receiver appeal from the judgment of the Special Master, as approved by the District Court. Consequently this matter must be disregarded at this time.

As stated in *Merriman v. Chicago, etc. Co.* (C. C. A. 7th), 66 Fed. 663:

“It is, by the well-settled principles of the law, *too late* to present a question for the *first* time on a petition for a rehearing, * * *.” (P. 664.)

See also:

Bassick Mfg. Co. v. Adams, etc. Corp. (C. C. A. 2d), 54 Fed. (2d) 285.

Passing this fatal defect for the moment, we submit that both the Receiver, and the Security Bank as trustee for the bondholders, are not in any position to assert defenses *not available to Richfield*. These parties have no greater rights in the premises than Richfield.

Fourth St. Nat'l. Bk. v. Yardley, 165 U. S. 634, 41 L. Ed. 855:

“The receiver took *no greater* rights in the property of the insolvent bank which came into his possession than that which the insolvent bank possessed. (Citing cases.)” (41 L. Ed. 865.)

In *Fosdick v. Schall*, 99 U. S. 235, 25 Law Ed. 339, the Court said:

“The possession taken by the receiver is only that of the court, whose officer he is, and adds *nothing* to the previously existing title of the mortgagees. He holds, pending the litigation, for the benefit of whom-

soever in the end it shall be found to concern, and in the meantime the court proceeds to determine the rights of the parties upon the same principles it would if no change of possession had taken place.” (25 L. Ed. 342.)

Black v. Manhattan Trust Co. (D. C. Ore.), 213 Fed. 692, states the rule:

“A receiver by his appointment as such acquires no greater or superior right or interest in the property coming into his hands than the debtor had, and in this relation may be said to stand in the shoes of the debtor; and, furthermore, as a general rule *the receiver takes the property in the same plight and condition, and subject to the same equities and liens*, as he finds it in the hands of the person or corporation out of whose hands it is taken.” (P. 693.)

In *U. S., etc. Co. v. Missouri, etc. Co.* (C. C. A. 5th), 269 Fed. 497 (*certiorari* denied 256 U. S. 699), the same rule is announced when the Court stated that:

“A receiver *does not represent the justiciable rights of the parties* to the litigation of which he is receiver * * *.” (P. 501.)

The proposition is so elementary that numerous other cases can be readily cited to the same effect. See also:

Grant v. Phoenix, etc. Co., 106 U. S. 429, 27 Law Ed. 237, 238;

Auten v. City, etc. Co. (C. C. Ark.), 104 Fed. 395, 400;

Geddes v. Reeves, etc. Co. (C. C. A. 8th), 20 Fed. (2d) 48, 53 (*certiorari* denied 275 U. S. 556);

Central, etc. Co. v. Missouri, etc. Co. (D. C. Mo.),
28 Fed. (2d) 176, 177;

Home Trust Co. v. Miller Pét. Co. (D. C. Kans.),
27 Fed. (2d) 748, 750;

Kennison v. Kanzler (C. C. A. 6th), 4 Fed. (2d)
315, 317;

Vincent National Drug Stores, Inc. (D. C. Pa.), 3
Fed. (2d) 504, 505;

Witherspoon v. Choctaw, etc. Co. (C. C. A. 8th),
56 Fed. (2d) 984, 988;

In Re Greyling Realty Corp. (C. C. A. 2nd), 74
Fed. (2d) 734, 737.

Nor does the fact that Universal has a lien by operation of law change the relation of the Receiver to the property. In *Wright v. Seaboard, etc. Corp.* (C. C. A. 2d), 272 Fed. 807, the Court pointed out that the appointment of the Receiver did not disturb pre-existing liens on the property, and continued:

“It makes no difference whether the lien has its origin in contract or *arises by operation of law.*” (P. 812.)

For that matter the same rule has been set forth by this Court in the case of *Nicholson v. Western, etc. Co.* (C. C. A. 9th), 60 Fed. (2d) 516, 518.

Neither can the Security Bank, as trustee for bond holders, claim any position higher than that of Richfield. Practically all the property here involved comes under the

trust indenture only by virtue of the after-acquired property clause. The bondholders thus are not bona fide purchasers for value. [Tr. pp. 204, 205.]

Fosdick v. Schall, 99 U. S. 235, 25 L. Ed. 339:

“They (the mortgagees) are in no sense purchasers of the cars. The mortgage attaches to the cars, if it attaches at all, because they are ‘after acquired’ property of the company; but as to that class of property it is well settled that the lien attaches subject to all the conditions with which it is encumbered when it comes into the hands of the mortgagor. *The mortgagees take just such an interest in the property as the mortgagor acquired; no more, no less.*” (25 L. Ed. 343.)

The same effect: *Holt v. Henley*, 232 U. S. 637, 58 L. Ed. 767; *Detroit Steel Cooperage Co. v. Sistersville*, 233 U. S. 712, 58 L. Ed. 1166.

None of the authorities presented by the Receiver under this point in anywise detract from the foregoing rules. Thus, in *Clark v. Bacorn* (C. C. A. 9th), 116 Fed. 617, the creditor claimed a judgment lien obtained *subsequent* to receivership. Also, in *Porter v. Boyd* (C. C. A. 3rd), 171 Fed. 305, the creditor claimed a *secret lien* on personal property, which was invalid because it was given to the creditor by the defunct corporation without the change of possession required by law.

In *Harry E. Jones, Inc. v. Kemp* (C. C. A. 9th), 74 Fed. (2d) 623, there is presented a beneficiary of a trust who was unsuccessful in tracing a part of his funds. To aid him in overcoming this defect, an attempt was made to invoke an estoppel against the Receiver. Since such an estoppel could not have been invoked against the association prior to receivership, it is at once evident that the estoppel would be ineffective against the Receiver. While the estoppel was ineffective, it is to be noted that a trust *was* imposed in *Jones v. Kemp* to the extent that the tracing was successful. There is nothing in the case that would indicate any intention by this Court to overrule its conclusion in *Nicholson v. Western, etc. Co., supra*.

The remaining authorities cited by the Receiver, which are treated in other portions of this answer, do not lend any support to his claim that merely because a receivership is involved, a just claim for priority, such as that of Universal's, should be denied.

All of the Receiver's cases fall far short of the claim that he should not be placed in the shoes of Richfield so far as Universal's lien rights are concerned. Certainly the Receiver has no greater rights than Richfield, and he is bound to take Richfield's property subject to the equities existing against Richfield. The *mere* appointment of the Receiver could not divest Universal of its lien. This result follows whether the Receiver represents six thousand creditors or only six creditors.

III.

The Decision Herein Properly Determined That Universal Had Made Out a Prima Facie Case With the Use of the Closing Balances.

A. UNDER THE FACTS OF THIS CASE THE CLOSING BALANCES WERE THE ONLY ONES THAT COULD BE USED.

As the Receiver did not appeal from the award of a prior lien to Universal to the extent of \$403,000.00; and the Security Bank in its petition for rehearing seeks same only on the increase of the lien awarded by this Court on the cross-appeal of Universal, it is submitted that the only matter before this Court is the propriety of using the closing balances for the purposes of this increased award.

We have no quarrel with the authorities cited by the Receiver to the effect that the burden of proof is on the *cestui* to trace his funds into property in the hands of the Receiver. But we submit that on proving the existence of the trust, the deposit of Universal funds in the Richfield account in the Security Bank, the daily bank balances and the purchase of property with money from that account, we have amply fulfilled our burden.

It is a well known fact, universally recognized, that the closing balances in a bank account are the *only true balances* of that account, and, contrary to the method used by the Special Master, these closing balances give due and

proper consideration to all items credited or charged against the account.

The bald statement of the Receiver that the closing balances are *not* the only true balances is not sufficient, even were it correct. This whole argument is based upon the false premise that the bank recognizes changes in the account during a day, and, for example, would only certify checks against the *true* balance of the account at the moment that the check is presented. The record clearly discloses that certification would be made if the *ledger account contained "sufficient funds to cover the check."* [Tr. p. 101.] It is only in the case where the account on the ledger does not show sufficient funds that the bank would examine the deposits of the day that have not been posted. In that event, and if there are sufficient deposits the bank would certify the check even though the deposits were not posted. [Tr. p. 101.] But such procedure would not take into account checks received in the clearings and not posted, nor would it necessarily result in a true balance. At no place in the record does it appear that it would be necessary to obtain the true balance for the purpose of certification—rather it is merely that the account should have an *excess* of funds over the amount of the certified check.

The Receiver states that the chief clerk of the bank testified that if a check was presented for *payment or certification*, the teller would look not only to the posted balance but also to the unposted items to ascertain the balance in the account. *This statement is not correct and*

does not appear in the record. From this false premise the Receiver concludes that at any given moment of a day the bank could ascertain the accurate balance of the account. That the bank *could* so do is not disputed if the bank's machinery were brought to a pause while the calculations were being made. That the bank *never* did so do is disclosed by the actual happenings at the bank. [Tr. pp. 100 to 102.] It is all too evident that in the course of an ordinary commercial day the bank would not take time out to render an accurate balance of the account merely for the purpose of determining whether a check should be paid or certified.

The statement of the Receiver that the first transaction each morning must be a debit for the reason that checks came from the clearing house before the bank opened for business is based upon the erroneous assumption that the mere receipt of those items at the bank is sufficient to constitute a charge upon the depositor's account. Receipt of the checks does not constitute an acceptance of them by the bank as the bank may refuse payment of them and return them to the clearing house any time before 2:30 p. m. [Tr. p. 99.] Could anyone contend that a check that was refused payment could have any effect upon the account? Until the time has gone by for returning the checks to the clearing house, or until they are charged against the depositor's account by proper posting, we submit that they may not be properly considered as depletions of that account.

Despite the assertion of counsel, we respectfully submit that we have always contended that the intermediate posted balances on the bank's books during the course of the day are at least better evidence of the status of the account during the day than the method contended for by petitioners. (See Univ. Br. as Cross-App. pp. 24 to 35.) Concededly they do not show accurate balances.

If the evidence could be obtained as to the actual condition of the bank account at any particular moment of a day, then, manifestly, the Security Bank was in the best position to obtain such evidence. That it was impossible to so do, does not and should not militate against the lien of Universal, but, on the contrary, merely gives rise to the conviction that the closing balances are the only definite figures of the bank account. From these figures *must*, of necessity, be taken the low balances. Ample legal support for this conclusion is afforded by the case of *Brennan v. Tillinghast* (C. C. A. 6th), 201 Fed. 609. This case is discussed at length in the brief of Universal as appellee at pp. 15, 16, to which we respectfully refer this Court.

The Supreme Court in one of its late cases, *Jennings v. U. S. F. & G. Co.*, 79 L. Ed. (Adv. Op.) 355, has occasion to refer to the condition of a bank account there involved:

“There was not even a partial or proportionate payment that could have found its way into the vaults, for the balance *at the close of the operations of the day* was adverse to the collector and in favor of the clearing house.” (79 L. Ed. 359.)

B. WITHOUT ANY CONTRARY EVIDENCE, THE PRIMA FACIE CASE OF UNIVERSAL MUST STAND.

While the Receiver's brief attacks with vigor many of the authorities cited upon this point, he passes without comment *Central Nat'l. Bank v. Conn. Mut. Life Ins. Co.*, 104 U. S. 54, 26 L. Ed. 693, where it was stated in a headnote by the Court:

“That, so long as trust property can be traced and followed into other property into which it has been converted, the latter remains subject to the trust, and that if a man mixes trust funds with his own, the whole will be treated as the trust property, except so far as *he may be able to distinguish what is his own*, are established doctrines of equity and apply in every case of a trust relation, and to moneys deposited in a bank account, and the debt thereby created, as well as to every other description of property.” (Headnote 3.)

and a decision by the Circuit Court of Appeals of this circuit—*American Surety Co. v. Jackson*, 24 Fed (2d) 768, where it is said:

“It will thus be seen that the rule itself rests largely on a legal fiction. But if there is a presumption that trust funds have not been wrongfully misapplied or criminally used by the officers of the bank, as held by this court in the Spokane County case, *supra*, and such a presumption no doubt obtains, it would seem to follow as a necessary corollary that *the burden was on the bank* or its successor in interest to prove that the trust funds or some part of them were in fact wrongfully misappropriated or criminally used by the bank. This presumption in nowise conflicts with the

rule that in the end the claimant must trace the funds and establish his claim thereto by clear and satisfactory proof as against the receiver who represents all creditors.” (P. 770.)

In the case of *In re Byrne* (C. C. A. 2nd), 32 Fed. (2d) 189, cited by the Receiver, the Court specifically approved the doctrine that the proof of the trust there involved did make a *prima facie* case.

“So far as the debit comprised charges not traced to withdrawals by the executors themselves, we think the proof was *prima facie* sufficient. The petitioners put in evidence this account *as it appeared in the bankrupts’ books.*” (P. 191.)

Furthermore, if there were any evidence as to the *actual* time of day of the purchase of certain properties, or of the giving of checks for those properties, or of the deposits of funds in the bank account, this evidence was not brought forth by the Receiver. The Receiver was given the opportunity at the hearing before the Special Master to prove, if he could, that instead of funds of Universal *presumably* going into the purchase of this property, it was *actually* the funds of Richfield that so did. The Receiver, however, did not or could not avail himself of this opportunity of proof.

We respectfully submit that this Court correctly stated the law when it held that “proof of the lowest daily closing balances between misappropriations and purchases of the identified properties constituted a *prima facie* showing of the lowest intermediate balances,” and that the burden was on the defendant to come forward with evidence in rebuttal, if it could.

IV.

The Decision of the Instant Case Does Not Contravene the Decisions of the Supreme Court or Circuit Courts.

The Receiver maintains that the decision herein is contrary to a number of decisions set forth under his point II c; including two Supreme Court cases and one Circuit Court case.

The two Supreme Court decisions are those of *First National Bank of Princeton v. Littlefield*, 226 U. S. 110, and *Schuyler v. Littlefield*, 232 U. S. 707. Both arose out of the failure of Brown & Co. and involved the efforts of certain *cestuis* to secure a preference. In both cases the effort of the *cestuis* required them to trace funds through the enormous banking transactions of August 24th and 25th, the date of the failure.

In the first case, the defendant showed that against an opening balance of \$130,000, there had been drawn on the day in question over \$400,000 in checks for other purposes *before* drawing the check for the collateral upon which plaintiff was claiming his lien. [Rec. Pet. p. 48.] The defendant in that way had offered evidence to controvert any case that might have been established. No such evidence was offered by Richfield. Furthermore, there were other trust claimants who were similarly situated and whose equities equalled those of plaintiff. [Rec. Pet. pp. 51, 52.] Of course any preference granted to plaintiff under the circumstances would have been inequitable. It was not the case, as it is here, of a *cestui* owning a lien that is prior to the claims of general creditors.

Also in the *Schuyler v. Littlefield* case, the defendant had offered evidence to controvert that of plaintiff. The evidence showed that the check containing plaintiff's money had been deposited in the bank account prior to the exhaustion of that account on August 25th at 11:00 a. m., by the certification of a check. This effectively eliminated all questions of tracing trust funds even if they were in the account. No similar situation is involved in the instant case. The case of *Schuyler v. Littlefield* is authority for the doctrine that trust funds once dissipated are not thereafter made to reappear by subsequent deposits. Universal entirely agrees with this principle, and in this entire proceeding has adhered strictly to this doctrine. Both of these Supreme Court cases are more fully discussed in the briefs of Universal.

The case of *Connolly v. Lang* (C. C. A. 7th), 68 Fed. (2d) 199, also cited by the Receiver in this connection, involves a depositor in an insolvent bank seeking a preference. It was the decision of the Court that there was *no* trust relation, nor any proof of any augmentation of assets of the bank. The case is therefore not in point.

The Receiver, to bolster his claim under this point, cites the opening balances, checks, and deposits in the Richfield bank account between December 23rd and December 27th. [Rec: Pet. p. 44.] The Receiver does not hesitate to go outside the record for his material, but notwithstanding this, it is only necessary to point out that Universal *is not attempting to trace any of its funds past December 23rd.* [Tr. p. 102.]

A large number of additional cases, not heretofore cited by any party to this proceeding, have been submitted by

the Receiver in his petition. In a number of those cases it was held that no trust existed on the particular facts. These cases are:

Borman v. Sullivan, 77 Fed. (2d) 342;

Connolly v. Lang, 68 Fed. (2d) 199, discussed, *supra*;

First Nat'l., etc. v. City of Miami, 69 Fed. (2d) 346;

Kershaw v. Jenkins, 71 Fed. (2d) 647;

Merchants, etc. v. Austin, 48 Fed. 25;

Swan v. Children's, etc., 67 Fed. (2d) 84.

Manifestly, such cases are of no aid whatsoever since it is stipulated and is a part of the record in this case that a *trust did exist* in favor of Universal.

A number of the Receiver's cases are merely efforts by people who are beneficiaries under constructive trusts to impress the amount due them on the general assets of the defunct bank, or on the estate of the bankrupt, without any *specific* showing on the question of tracing of funds. These cases are:

In Re Brunsing, etc., 169 Fed. 668;

In Re Byrne, 32 Fed. (2d) 189;

Harmer v. Rendleman, 64 Fed. (2d) 422;

Matthews', etc., In Re, 238 Fed. 785;

Mulligan, In Re, 116 Fed. 715;

Multnomah Co. v. Oregon, etc., 61 Fed. 912;

Poole v. Elliott, 75 Fed. (2d) 772;

Wisdom v. Keen, 69 Fed. (2d) 349.

That situation is, of course, entirely different than the instant case, for there has been no attempt herein to spread the lien of Universal *generally* upon the assets of Richfield, and, on the contrary, a very *specific* lien is asked on each parcel of property purchased from moneys in the commingled funds.

Other cases collected by the Receiver in his petition prevent the beneficiary from following his funds in particular accounts because of gaps in the condition of these bank accounts for a period of days, or because of an overdraft in the bank account prior to receivership or bankruptcy. These cases are:

Blumenfeld v. Union, 38 Fed. (2d) 455;

Bogena, In Re, 76 Fed. (2d) 950;

Marshburn v. Williams, 15 Fed. (2d) 589;

Pottorff v. Key, 67 Fed. (2d) 833;

Titlow v. McCormick, 236 Fed. 209.

Again these cases are of no assistance because Universal has at all times admitted that it was not entitled to follow its proceeds beyond the 8th day of January, 1931, when an overdraft occurred in the bank account of Richfield. The condition of the Richfield bank account from day to day of the period in question; the opening balances, the closing balances, and the posted balances that intervened between these two, are all in evidence. There is not a gap of a single day in the proof of the condition

of Richfield's bank account between the taking and deposit of Universal's money and the purchase of properties with moneys from said commingled fund.

If *Nixon State Bank v. First State Bank of Bridgeport* (Ala.), 60 So. 868, is contrary, it would not be controlling on the federal courts. This is true of all other state cases in the same category. It might be observed that in a subsequent case, *Hanover Nat'l. Bank v. Thomas*, 217 Ala. 494, 117 So. 42, the Alabama courts were in full accord with the doctrine of tracing funds through commingled accounts.

None of the foregoing cases are at all comparable to the instant case. Here there was an admitted trust, an admitted purchase of definite parcels of property from the commingled account and no intervening exhaustion of the account at the time of the purchases.

We cannot help but be reminded in this connection of the statement of Chief Justice Marshall in *Cohens v. Virginia*, 6 Wheaton 265, 5 L. Ed. 257:

“* * * That general expressions, in every opinion, are to be taken in connection with the case in which those expressions are used.” (5 L. Ed 290.)

V.

The Doctrine of In re Oatway Properly Applies to
This Case.

A large portion of the Receiver's brief is devoted to an attempt to defeat Universal's *whole* claim. In answer to that contention, may we call the Court's attention to the fact that any claim now advanced that Universal has not established its right to any lien upon Richfield properties cannot be raised at this time by the Receiver, who failed to appeal.

As aptly stated by the Supreme Court in a similar situation in the case of *Fitchie, et al. v. Brown, et al.*, 211 U. S. 321, 53 L. Ed. 202:

“We are of opinion that counsel for the executors had no right to appear and be heard *against* the decree, *no appeal having been taken from it by his clients.*” (53 L. Ed. 205.)

See also:

Marine Transit Corp. v. Dreyfus, 284 U. S. 263,
76 L. Ed. 282, 290.

The Special Master found, and the Trial Court held, that Universal was entitled to a lien to the extent of \$403,000 without proving that Richfield intended to use Universal funds in the purchase of certain properties, and the Receiver did not appeal from that judgment. If the present argument is now presented to support the petition

of the trustee for the bondholders, we point out that it has now acquiesced in this Honorable Court's affirmance of that judgment and is only requesting a rehearing of that portion of the judgment that increased Universal's lien from \$403,000 to \$849,000.

As the point was fully considered in our brief as appellee in which, we submit, *all* the present arguments of the Receiver were fully answered, and as all of the Receiver's cases from the Supreme Court and the Circuit Courts have been heretofore cited by the various parties and are discussed at length in our briefs, we will merely refer the Court to the cases that fully support Universal:

In Re Oatway (1903), 2 Ch. Div. 356;

Brennan v. Tillinghast, 201 Fed. 609;

In Re Pacat, 27 F. (2d) 810;

Fiman v. So. Dak., 29 F. (2d) 776;

Primeau v. Granfield, 184 Fed. 480;

and to our brief as appellee in which we discuss at length the application of these cases. (See Univ. Br. pp. 12, *et seq.*)

VI.

The Decisions of the California State Courts Are Not Binding Upon the Federal Courts Insofar as They Affect the Tracing of Trust Funds. Were the California Cases Binding, We Still Submit That They Are Favorable to Universal's Position and Not to the Receiver's.

When this matter was being tried before the Special Master, briefs were filed by all of the parties thereto, including the Receiver. The Receiver *then* took the view that the federal rules were controlling on the question of tracing of funds, citing in support thereof the cases of *John Deere Plow Co. v. McDavid* (C. C. A. 8th), 137 Fed. 802, and *Beard v. Independent District* (C. C. A. 8th), 88 Fed. 375. We quote from that brief:

“The matter of tracing funds is a matter of equity jurisprudence upon which the Federal Courts *are bound* by the decisions of the United States Supreme Court and they do not follow State Court decisions unless the latter are based on interpretations of state statutes or are in accord with the weight of authority generally.” (P. 44.)

The Security Bank, in the brief before this Court likewise stated that the federal equity doctrine as to the tracing of trust funds was controlling, and cited the same federal cases. (Br. Sec. Bk., p. 25.)

Universal (in its brief as appellee, on page 20 thereof) conceded that the rules promulgated by the federal courts on the tracing of funds were controlling, but submitted that the decisions of the state courts were at least entitled to consideration. Thereupon a number of state decisions

were cited by Universal, including *Mitchell v. Dunn*, 211 Cal. 129.

This entire proceeding has been tried before the Special Master, the District Court, and upon the date of the filing of the petition of the Receiver, before the Circuit Court on the theory advanced by and agreed to by all parties that the federal rules were controlling.

Now, for the *first* time, the Receiver desires to take the opposite tack and claim that the rules of the state courts are the ones to be followed, and not those of the federal courts. A new issue not heretofore presented in any of the briefs is now being tendered to this Court, and under the familiar rule pertaining to rehearings, this new issue might properly be disregarded. *Merriman v. Chicago, etc. Co., supra*.

In his petition, the Receiver now seeks to distinguish the federal cases hereinbefore cited on the grounds that when the state court decisions attempt to create preferences and priorities without any tracing the state rule is inapplicable because it is then a matter of preference rather than property. If we understand counsel, we feel constrained to remark that this is a distinction without a difference. In each one of the federal cases the sole purpose involved was a tracing of trust funds, and the decision in *John Deere Plow Co. v. McDavid, supra*, squarely and unequivocally decides that the tracing of trust funds concerns,

“* * * a rule of preference in equity, and upon that question the Federal decisions *must* control in this court, * * *.”

Likewise in *Beard v. Independent District, supra*, the matter covered was the tracing of trust funds. Such right to follow trust funds was not created by statute but was based upon general principles of equity, and the rulings of the Iowa Supreme Court there involved could not be conclusive. The decisions of the Iowa Supreme Court could not rightfully be said to “constitute a rule of property which other courts are bound to follow.”

It is quite appropriate to call attention to two of the cases in the Receiver's petition. In *Wisdon v. Keen*, 69 Fed (2d) 349, the Court says:

“Whether the question be one of general equity jurisprudence or of the application of the federal law relating to insolvent national banks, *the views of the federal courts must in such courts be controlling.*”
(p. 350.)

Elmer v. Kemp (C. C. A. 9th), 67 Fed. (2d) 948, decided by this Court, should have put at rest these new ideas of the Receiver. There was an attempt to impress a trust on all the real and personal property of the Elmer Oil Company. Needless to say, the property was located in California. In support of the claim, the claimants cited *Byrne v. McGrath*, 130 Cal. 316, which case was in their favor on the relevant facts. This Court *absolutely* refused to follow the state decision, saying:

“Moreover, in a federal court of equity, we must decide cases in accordance with our view of the general principles of equity jurisprudence. *Kuhn v.*

Fairmont Coal Co., 215 U. S. 349, 363, 30 S. Ct. 140, 54 L. Ed. 228; Russell v. Southard, 12 How. 139, 13 L. Ed. 927; Neves v. Scott, 13 How. 268, 14 L. Ed. 140. The decisions of the particular state in which the cause of action arose are to be followed *only in so far as they conform to established principles of equitable jurisprudence.*" (P. 952.)

However, were this matter to be determined under the rules of the Court of California, we submit that the decision in *Mitchell v. Dunn, supra*, would be favorable to Universal.

"The law will not permit the trustee to say that the only permanent investment made with moneys from the fund was with personal funds, and that the dissipated funds belonged to the *cestui.*" (211 Cal. 136, 137.)

We submit that small comfort can be drawn by the Receiver from the case of *Mitchell v. Dunn, supra*. We must commend the Security Bank for its frankness in its brief, for in discussing this California case, it says: "As a matter of fact, *Mitchell v. Dunn* does not purport to follow the Oatway rule, although it will be conceded that *in effect it attains the same result.*" (Br. Sec. Bk., p. 64.)

In order that this answer should not be made unduly long, we make no reference to the various state cases from other states than California, as the doctrine must be controlled by the decisions of the federal courts.

Conclusion.

As a matter of fact, the Receiver and general unsecured creditors have very little to gain or lose by the present litigation, and this, regardless of how the litigation may terminate. The statement is made by the Receiver that this is not like a case between two individuals, whereas, as a matter of fact, the present issue very nearly *approximates* that situation. We have Universal on one hand claiming a lien by operation of law on certain specific assets (purchased with Universal's own money, unlawfully taken from it), and on the other hand the Security Bank claiming a lien on the great bulk of the same assets (which were not purchased with moneys belonging to its bondholders) under its trust indenture. Each party's lien, to the extent declared, of necessity *precedes* general unsecured creditors.

The prior lien that has been awarded Universal by this Court's opinion, approximately \$849,000.00, cuts down Universal's general unsecured claim to approximately \$333,000.00. To the amount that Security Bank has failed to impress its lien upon this same property under its trust indenture, it has been relegated to the category of a general unsecured creditor. In other words, the greater award under Universal's lien cuts down Universal's unsecured claim, but it also increases the unsecured claim of the Security Bank to an identical amount. Hence neither the Receiver or the other unsecured creditors are affected adversely by the decision.

The decision herein is within the proper scope of equity jurisprudence. As stated by the Supreme Court in *Adams v. Champion*, 79 L. Ed. (Adv. Op.) 366:

“Equity fashions a trust with *flexible* adaptation to the call of the occasion.” (79 L. Ed. 369.)

It is respectfully submitted that the petitions, and each of them, should be denied.

LEROY M. EDWARDS,

A. L. WEIL,

*Attorneys for Appellee and Cross-Appellant, Universal
Consolidated Oil Company.*

MARTIN J. WEIL,

O. C. SATTINGER,

Of Counsel.



United States
Circuit Court of Appeals

For the Ninth Circuit.

COMMISSIONER OF INTERNAL REVENUE,
Petitioner,

vs.

MRS. ALICE H. ELDRIDGE,

Respondent.

Transcript of the Record

Upon Petition to Review an Order of the United States
Board of Tax Appeals.

FILED

MAY 29 1935

PAUL P. O'BRIEN,

CLERK

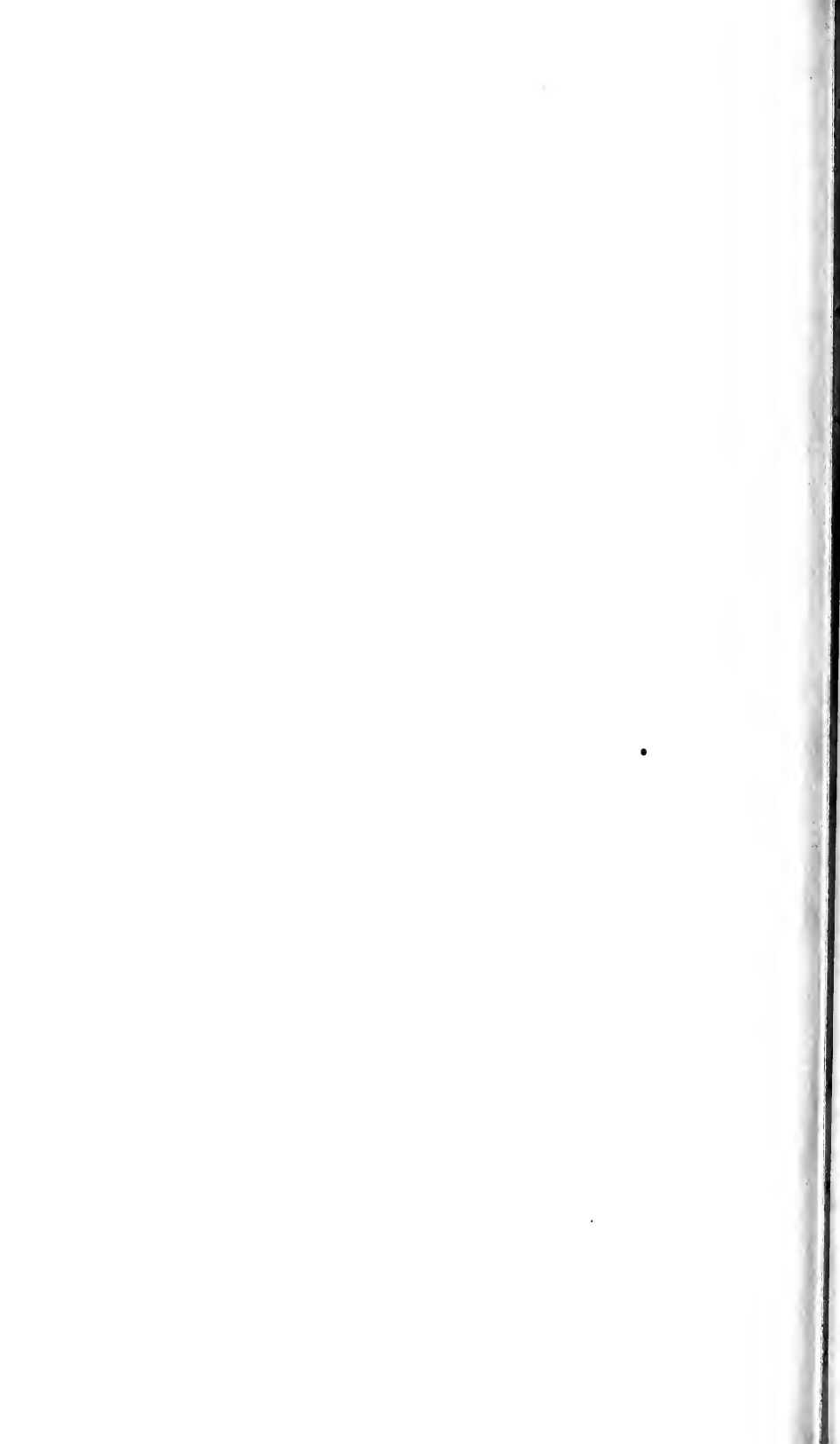

No. 7819

United States
Circuit Court of Appeals
For the Ninth Circuit.

—————
COMMISSIONER OF INTERNAL REVENUE,
Petitioner,

vs.

MRS. ALICE H. ELDRIDGE,
Respondent.

—————
Transcript of the Record

—————
Upon Petition to Review an Order of the United States
Board of Tax Appeals.

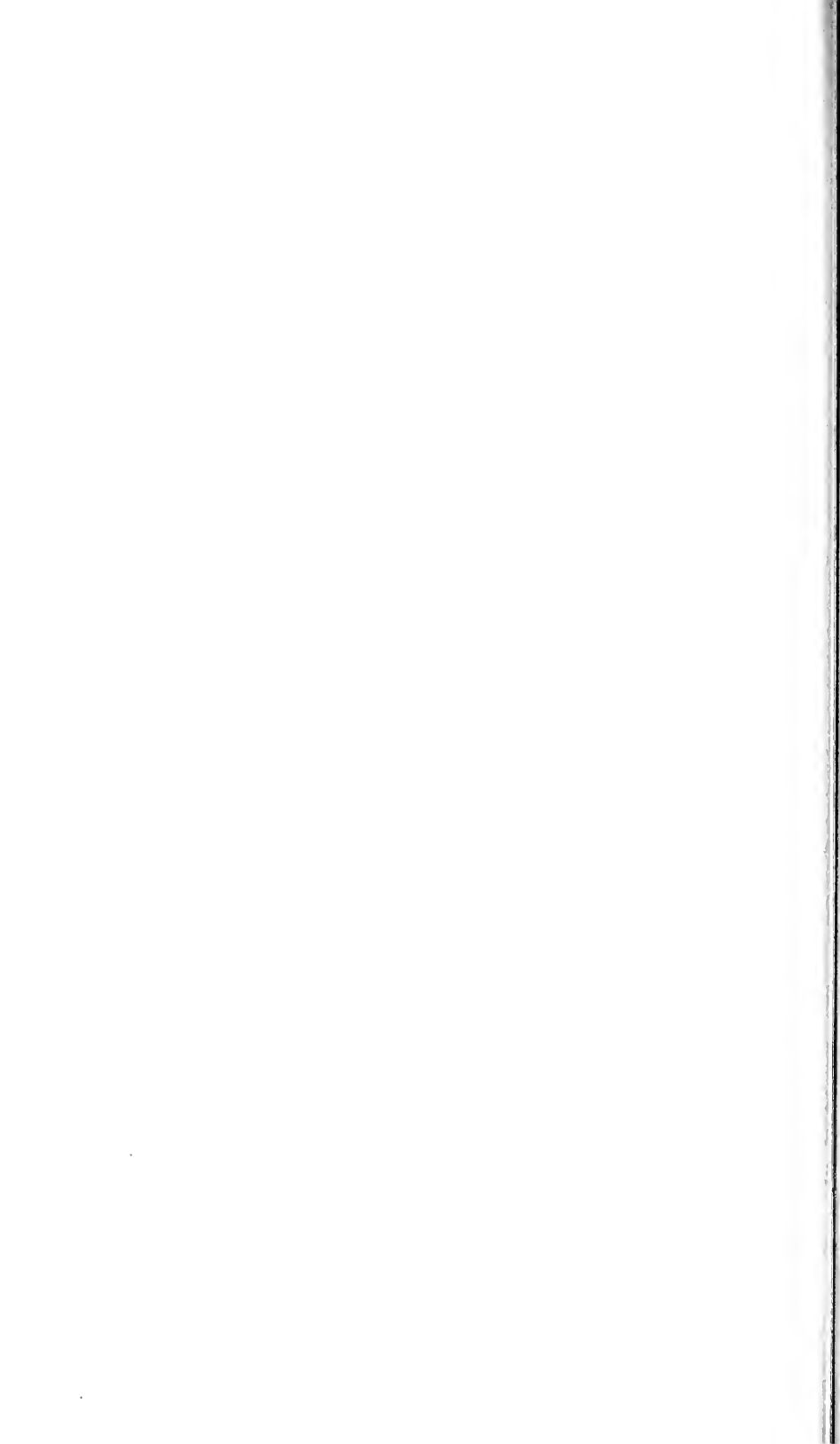

INDEX

[Clerk's Note: When deemed likely to be of an important nature, errors or doubtful matters appearing in the original certified record are printed literally in *italic*; and, likewise, cancelled matter appearing in the original certified record is printed and cancelled herein accordingly. When possible, an omission from the text is indicated by printing in *italic* the two words between which the omission seems to occur.]

	Page
Answer	11
Appearances	1
Clerk's Certificate	33
Decision	21
Docket Entries	1
Findings of Fact and Opinion.....	12
Notice of Filing Petition for Review.....	29
Petition	3
Notice of Deficiency dated February 24, 1932	6
Petition for Review, Proof of Service and Affidavit of Service.....	22
Praeceptum	32
Stipulation re Statement of Evidence, Printing and Decision	31



APPEARANCES:

For Petitioner:

SAMUEL F. RACINE, C. P. A.,
THOS. N. FOWLER, Esq.

For Respondent:

WARREN F. WATTLES, Esq.,
E. M. WOOLF, Esq.

Docket No. 64779

MRS. ALICE H. ELDRIDGE,

Petitioner,

vs.

COMMISSIONER OF INTERNAL REVENUE,
Respondent.

DOCKET ENTRIES:

1932

Apr. 19—Petition received and filed. Taxpayer notified. (Fee paid)

Apr. 19—Copy of petition served on General Counsel.

May 18—Answer filed by General Counsel.

June 3—Copy of answer served on taxpayer—Circuit Calendar.

1933

July 20—Hearing set in Seattle, Washington, beginning Sept. 11, 1933.

1933

- Sept. 18—Hearing had before Mr. Arundell—submitted. Briefs due Nov. 15, 1933.
- Oct. 11—Transcript of hearing of Sept. 18, 1933 filed.
- Nov. 14—Brief filed by taxpayer.
- Nov. 15—Brief filed by General Counsel.

1934

- July 31—Findings of fact and opinion rendered—C. Rogers Arundell, Division 7. Decision will be entered under Rule 50.
- Sept. 5—Motion for decision under Rule 50 filed by General Counsel.
- Sept. 7—Hearing set Sept. 26, 1934 on settlement.
- Sept. 26—Consent to settlement filed by taxpayer.
- Sept. 26—Hearing had before Miss Matthews on settlement under Rule 50—not contested—referred to Mr. Arundell for decision.
- Sept. 28—Decision entered—C. R. Arundell, Division 7.
- Dec. 14—Petition for review by U. S. Circuit Court of Appeals, 9th Circuit, with assignments of error filed by General Counsel.
- Dec. 27—Proof of service and affidavit of service filed by General Counsel.

1935

- Feb. 5—Motion for extension to April 13, 1935 to complete the record filed by General Counsel.

1935

- Feb. 5—Order enlarging time to April 13, 1935 for preparation of evidence and delivery of record entered.
- Feb. 27—Stipulation to incorporate statement of evidence by reference and with regard to printing and decision filed.
- Feb. 27—Praecipe filed with proof of service thereon. [1*]

United States Board of Tax Appeals

Docket No. 64779

MRS. ALICE H. ELDRIDGE,

Petitioner,

vs.

COMMISSIONER OF INTERNAL REVENUE,

Respondent.

PETITION

The above named petitioner hereby petitions for a redetermination of the deficiency set forth by the Commissioner of Internal Revenue in his notice of deficiency, IT:AR:E-1; LC-60D, dated February 24, 1932, and as a basis of her proceeding alleges as follows:

1. The petitioner is an individual with principal office at 802 East Pike Street, Seattle, Washington.

*Page numbering appearing at the foot of page of original certified Transcript of Record.

2. The notice of deficiency (a copy of which is attached and marked Exhibit A) was mailed to petitioner on February 24, 1932.

3. The taxes in controversy are income taxes for the calendar year 1929, and for approximately \$2,400.00.

4. The determination of tax set forth in the said notice of deficiency is based upon the following errors: [2]

(a) The Commissioner has disallowed a loss of \$16,552.00 on the sale of corporate stock, by petitioner.

(b) The Commissioner has added \$4,986.30 to the income of petitioner in 1929 on account of dividends alleged by the respondent Commissioner to have been received by petitioner.

5. The facts upon which the petitioner relies as the basis of this proceeding are as follows:

(a) During the year 1929 petitioner sold stock in the Carnation Milk Company for \$30,000.00, which stock had cost \$39,604.00, and in which petitioner held a community one-half interest.

(b) During the year 1929 petitioner sold stock in the Fox Theatres Company for \$5,000.00 which had cost \$28,500.00 and in which petitioner held a community one-half interest.

(c) During the year 1929, petitioner did not receive a community one-half of a dividend

from the Eldridge Securities Company in the amount of \$15,825.00 as alleged by respondent in paragraph 4 of the statement attached to the deficiency letter sent to petitioner, but instead, received a community one-half of the dividend of \$5,852.41 from the Eldridge Securities Company, referred to in the same paragraph of the deficiency letter.

6. Wherefore, the petitioner prays that this Board may hear the proceeding and redetermine the deficiency alleged by the respondent Commissioner.

SAMUEL F. RACINE,
Counsel for Petitioner.

Address of Counsel:
923 Insurance Building,
Seattle, Washington.

C. L. STONE,
Counsel for Petitioner.

Address of Counsel:
923 Insurance Building,
Seattle, Washington. [3]

EXHIBIT A
TREASURY DEPARTMENT
Washington

NP-2-28

Office of
Commissioner of Internal Revenue

February 24, 1932.

Mrs. Alice H. Eldridge,
3115 West Laurelhurst,
Seattle, Washington.

Madam:

You are advised that the determination of your tax liability for the year(s) 1929 discloses a deficiency of \$2,124.13, as shown in the statement attached.

In accordance with section 272 of the Revenue Act of 1928, notice is hereby given of the deficiency mentioned. Within sixty days (not counting Sunday as the sixtieth day) from the date of the mailing of this letter, you may petition the United States Board of Tax Appeals for a redetermination of your tax liability.

HOWEVER, IF YOU DO NOT DESIRE TO PETITION, you are requested to execute the enclosed agreement form and forward it to the Commissioner of Internal Revenue, Washington, D. C., for the attention of IT:C:P-7. The signing of this agreement will expedite the closing of your return(s) by permitting an early assessment of any deficiency and preventing the accumulation of interest charges, since the interest period terminates thirty days after filing the enclosed agreement, or

on the date assessment is made, whichever is earlier ;
WHEREAS IF NO AGREEMENT IS FILED,
interest will accumulate to the date of assessment
of the deficiency.

Respectfully,

DAVID BURNET,
Commissioner.

By J. C. WILMER (Signed)
Deputy Commissioner.

Enclosures :

Statement
Form 882
Form 870 [4]

STATEMENT

IT:AR:E-1

LC-60D

In re: Mrs. Alice H. Eldridge,
3115 West Laurelhurst,
Seattle, Washington.

Tax Liability

Year—1929

Tax Liability—\$2,579.93

Tax Assessed—\$455.80

Deficiency—\$2,124.13

Reference is made to the report of the internal
revenue agent in charge, Seattle, Washington, and
to your protest dated October 22, 1931.

Careful consideration has been accorded your
protest in connection with the agent's findings. The

adjustments recommended by the agent have been approved by this office.

Net income reported on return	\$24,225.67
-------------------------------	-------------

Add:

1. Interest transferred from dividends	628.42
2. Loss on sale of corporate stock disallowed	16,552.00
3. Sale of real estate understated	1,000.00
4. Dividends	4,986.29

Total	\$47,392.38
-------	-------------

Deduct:

5. Interest reported as dividends	628.42
-----------------------------------	--------

Adjusted net income	\$46,763.96
---------------------	-------------

Explanation of Adjustments

1 and 5. These adjustments are made for the purpose of segregating interest received from dividends received.

2. The loss claimed on the transfer of 1,000 shares of Carnation Milk Company stock and 1,000 shares Fox Theatres stock is disallowed because the circumstances surrounding the deal indicate that it was not a bona fide transaction. [5]

3. The profit on the sale of the Yakima property has been adjusted as follows:

Profit as computed by revenue agent	\$ 2,579.18
Amount reported on return	579.18
	<hr/>
Increased profit	\$ 2,000.00
One-half taxable to husband	1,000.00
	<hr/>
Amount added to your income	\$ 1,000.00
4. Dividends have been adjusted as follows:	
Dividend of the Eldridge Securities Company declared December 17, 1929	\$15,825.00
Less:	
Dividends declared December 22, 1928 and reported on your re- turn for 1929	5,852.41
	<hr/>
Difference	\$ 9,972.59
Amount taxable to your husband	4,986.30
	<hr/>
Amount added to your income	\$ 4,986.29

It is obvious that under the resolution of December 17, 1929 the amount of the dividends declared was subject to the demand of the stockholders and therefore taxable in 1929.

Computation of Earned Income Credit

Earned net income	\$ 6,082.50
Less:	
Personal exemption	1,750.00
	<hr/>
Balance	\$ 4,332.50

Normal tax at $\frac{1}{2}\%$ on \$4,000.00	\$	20.00
Normal tax at 2% on \$ 332.50		6.65
		<hr/>
Total tax	\$	26.65
		[6]
Credit of 25% of \$11.00	\$	2.75

Computation of Tax

Net income as adjusted		\$46,763.96
Less:		
Dividends	\$42,816.41	
Personal exemption	1,750.00	44,566.41
	<hr/>	<hr/>
Balance subject to normal tax	\$	2,197.55
Normal tax at $\frac{1}{2}\%$ on \$2,197.55	\$	11.00
Surtax on \$46,763.96		2,571.68
		<hr/>
Total tax	\$	2,582.68
Credit for earned net income		2.75
		<hr/>
Total tax assessable	\$	2,579.93
Tax previously assessed		455.80
		<hr/>
Deficiency	\$	2,124.13
		[7]

State of Washington,
County of King.—ss.

Mrs. Alice H. Eldridge, being duly sworn, says that she is the petitioner above named; that she has read the foregoing petition, or had the same read

to her, and is familiar with the statements contained therein, and that the facts stated are true, except as to those facts stated to be upon information and belief, and those facts she believes to be true.

MRS. ALICE H. ELDRIDGE

Subscribed and sworn to before me this 14 day of April, 1932 A. D.

[Seal]

JOHN H. SIMPSON

[Endorsed]: Filed Apr. 19, 1932. [8]

[Title of Court and Cause.]

ANSWER.

The Commissioner of Internal Revenue, by his attorney, C. M. Charest, General Counsel, Bureau of Internal Revenue, for answer to the petition of the above-named taxpayer, admits and denies as follows:

1. Admits the allegations contained in Paragraph 1.

2. Admits the allegations contained in Paragraph 2.

3. Admits the allegations contained in Paragraph 3.

4. Denies that he erred in determining the tax set forth in said notice of deficiency, and further denies that he erred as alleged in Paragraphs 4(a) and 4(b) of the petition.

5. Denies any knowledge or information sufficient to form a belief as to the truth of the allega-

tions contained in Paragraphs 5(a), 5(b), and 5(c) of the petition, and therefore denies the same.

6. Denies generally and specifically each and every material allegation contained in taxpayer's petition not hereinbefore admitted, qualified or denied.

WHEREFORE, it is prayed that the taxpayer's appeal be denied.

(Signed) C. M. CHAREST,
General Counsel,
Bureau of Internal Revenue.

Of Counsel:

C. C. HOLMES,
Special Attorney,
Bureau of Internal Revenue.

k 5-13-32

[Endorsed]: Filed May 18, 1932. [9]

[Title of Court and Cause.]

Docket Nos. 64778, 64779.

Promulgated July 31, 1934.

1. The transfer of securities to a corporation in which petitioner A. S. Eldridge owned all the stock except qualifying shares, which were owned by members of his family, Eldridge receiving a credit to his personal account on the corporate books for the current market price, which was less than cost to him, is held to be a bona

fide sale and the resultant loss is an allowable deduction.

2. Dividends declared in 1929, the checks for which were mailed on December 31 of that year but not received by petitioner until January 2, 1930—this being the usual practice of the corporation in paying dividends—are held not income to petitioner in 1929.

Thomas N. Fowler, Esq., for the petitioners.

Warren F. Wattles, Esq., for the respondent.

The respondent determined deficiencies in income tax for the year 1929 as follows: A. S. Eldridge, Docket No. 64778, \$2,213.90; Alice H. Eldridge, Docket No. 64779, \$2,124.13.

Both petitioners challenge the same adjustments made by the respondent, namely, the disallowance of a claimed loss on the sale of securities, and the inclusion in 1929 income of dividends the checks for which were received in 1930. Other adjustments made by the respondent are not in issue.

FINDINGS OF FACT.

Petitioners are husband and wife, residents of the State of Washington, and all of the income in controversy or deductions claimed in these proceedings involve community income or community property. Petitioner A. S. Eldridge is, and at all times material here was, president of the Eldridge Buick Co., a corporation engaged in distributing and retailing automobiles. Eldridge owned all the

stock of the corporation except qualifying shares, which were owned by members of his family. [10]

In October 1929 Eldridge bought 1,000 shares of Carnation Milk Co. common stock at a cost of \$39,604, and 1,000 shares of Fox Theatres Corporation class A stock at a cost of \$28,500. Before the end of 1929 the market price of these stocks had materially declined, and Eldridge became pessimistic as to the future of the stocks and decided to sell them. At a conference in December 1929 with an accountant who had been employed for a number of years to handle accounting and financial matters, the accountant advised Eldridge to transfer the stock to the Eldridge Buick Co. rather than to sell it on the open market. The accountant suggested that course for the purpose of avoiding the brokerage fees that would be incurred in a sale on the market and for the further purpose of having the corporation benefit from any rise in the market price. It was his opinion that the market price would rise. Eldridge accepted the accountant's advice and on December 30, 1929, delivered to a securities company in Seattle the certificates for both blocks of stock, with directions to transfer them to the name of the Eldridge Buick Co. The transfers were made as directed and the new certificates in the name of the Eldridge Buick Co. were delivered to Eldridge in January or February 1930. The market value of the Carnation Co. stock on December 30, 1929, was \$30 per share and the market value of the Fox Theatres Corporation Class A stock on that date was \$5 per share.

The Eldridge Buick Co. sustained a loss in its operation for 1929, but at the close of the year it had a substantial surplus. Eldridge carried a personal account with the company, which at the close of 1929 had a debit balance of \$20,730.49. It had been the policy of Eldridge in prior years to have a credit balance in his account. At the close of 1929 he voluntarily reduced the salary he had drawn of \$36,000 to \$12,000 and the difference of \$24,000 was charged to his account, making his total debit balance \$44,730.49. A dividend of \$50,000 was declared out of the corporation's surplus, which was credited to the account of Eldridge at December 31, 1929. At the same time his account was also credited with \$35,000 representing the market value of the Carnation and the Fox stock transferred to the corporation. Upon completion of these adjustments his account showed a credit allowance of \$40,269.51. He received no cash from the company for the stock transferred to it.

No record was made on the minute books of the Eldridge Buick Co. concerning the transfer of the Carnation and the Fox stock. It had not been the custom to record such matters or purchases and sales on the minute books. On one or two previous occasions Eldridge had had stock of other corporations transferred to the Eldridge Buick Co.

In 1929 petitioner A. S. Eldridge was president of the Eldridge Securities Corporation, which was engaged in the business of [11] handling sales contracts on automobiles. The corporation had several

classes of stock outstanding and Eldridge was the owner of a large majority of the common stock. On December 17, 1929, the directors of the corporation adopted the following resolution:

Resolved that a semi-annual dividend be paid upon the capital stock of this company as follows:

Employees Preferred	5	per cent
Class A Preferred	3½	“ “
Common	50	cents per share

The resolution did not fix a time for payment of the dividends. On December 27, 1929, the corporation issued a check payable to "Eldridge Securities Corp. Dividend a/c" for \$40,486.25, which was cleared through the bank on December 28. On December 31, 1929, the treasurer of the corporation issued and mailed dividend checks to the individual stockholders. Eldridge received his dividend checks on January 2, 1930. Two of the four checks received by Eldridge were for dividends on stock of Mrs. Eldridge. The four checks, aggregating \$15,825, were cleared through the bank on January 3, 1930.

The dividends so received were not reported by petitioners in their 1929 returns, but were added to 1929 income by the respondent, one half to each petitioner, with certain adjustments not here involved. The books of Eldridge were kept on the cash receipts and disbursements basis.

The method of disbursing the dividend declared in December 1929 was in accordance with that which had been followed for several years. That is, the treasurer of the corporation drew checks against

the dividend account on the last day of the year and mailed them to stockholders on that day. The stockholders did not receive the checks until after the close of the year.

OPINION.

ARUNDELL: In their income tax returns for 1929 the petitioners claimed deductions for losses sustained on the sale of Carnation Co. and Fox Theatres stock. The deductions were disallowed by the respondent on the ground that the transfer of those stocks was not a bona fide transaction. The shares of stock were community property and were transferred by the husband, A. S. Eldridge, to a corporation in which he owned all the stock except qualifying shares and they were owned by members of his family. There is no question as to the formality of the transfer. The certificates were delivered up and new certificates issued in the name of the transferee corporation. The question for decision is whether, in view of the circumstances surrounding the transfer, recognition should be given [12] to it as a bona fide transaction resulting in a realized loss to petitioners.

The respondent's argument against recognizing the transaction as a bona fide sale is based on Eldridge's ownership of stock in the transferee corporation. Because of this stock ownership, it is argued, Eldridge had no one to deal with but himself.

It has been emphasized of late by the highest authority we have that the general rule, and the

rule for tax purposes, is that corporations and their stockholders are to be treated as separate entities. *Burnet v. Clark*, 287 U. S. 410: "A Corporation and its stockholders are generally to be treated as separate entities. Only under exceptional circumstances * * * can the difference be disregarded." *Dalton v. Bowers*, 287 U. S. 404: "Certainly, under the general rule for tax purposes a corporation is an entity distinct from its stockholders, and the circumstances here are not so unusual as to create an exception." *Burnet v. Commonwealth Improvement Co.*, 287 U. S. 415: "Counsel for respondent concede that ordinarily a corporation and its stockholders are separate entities, whether the shares are divided among many or are owned by one." *Klein v. Board of Supervisors* (a state tax case), 282 U. S. 19: "But it leads nowhere to call a corporation a fiction. If it is a fiction it is a fiction created by law with intent that it should be acted on as if true. The corporation is a person and its ownership is a nonconductor that makes it impossible to attribute an interest in its property to its members." See also *Edward Securities Corp.*, 30 B. T. A. 918; *Jones v. Helvering* (App., D. C.), — Fed. (2d) — (Apr. 23, 1934). In the *Jones* case, four brothers owning all the stock of a corporation transferred to it certain bonds at the then market price, which was less than cost to them, and claimed deductions in their income tax returns. The court held that the deductions were allowable, saying in part:

That the result of this was to enable taxpayers to claim a deductible loss in their income

and at the same time, by reason of control of the corporation, to retain an indirect interest in the bonds is undoubtedly true, but it is for the legislature and not the courts to find a way of taxing such a transaction. As the matter now stands, inequitable as it may appear, there is no statute condemning it.

In this connection it is noted that in the Revenue Act of 1934, section 24(a) (6), deductions are not allowable for losses on the sale or exchange between an individual and a corporation in which he owns more than 50 percent of the outstanding stock. But prior to the 1934 Act there was no such statutory restriction. Under the earlier acts the general rule was to recognize gains or losses on all sales or exchanges, and it was only in cases specially excepted—for example, in the reorganization cases—that gain or loss was not recognized. [13]

The weight of authority thus requires the recognition of the separate entities of corporations and their stockholders, and consequently effect must be given to gain or loss transactions between them in the absence of restricting statutes or unusual circumstances or peculiar facts which “may require disregard of corporate form.” *Burnet v. Commonwealth Improvement Co.*, *supra*. We see nothing so peculiar about the facts in this case as to warrant a holding that Eldridge and the corporation were one. The corporation was an entity of substance and the evidence indicates that it had been a going concern for some years. It was not, as in

Helvering v. Gregory, 69 Fed. (2d) 809, created and utilized solely for the purpose of reducing taxes. Nor do we have here any evidence of a persisting intention on the part of Eldridge to hold title to the stocks, as in *Sydney M. Shoenberg*, 30 B. T. A. 659. The evidence here is that Eldridge had made a definite decision to sell and it was only on the advice of his accountant that he transferred the shares to the corporation in which he was interested rather than to outside interests. Upon the evidence we are of the opinion that the transfer by Eldridge to the Eldridge Buick Co. was a bona fide transfer to a separate entity, and as such it resulted in a loss deductible under the taxing statute.

The other question is whether dividends declared by the Eldridge Securities Corporation were income in 1929 or 1930. The dividends were declared on December 17, 1929, a check transferring funds to the corporation's dividend account was issued on December 27 and cleared through the bank on December 28, and the individual dividend checks were drawn and mailed on December 31, 1929. The checks were received by Eldridge on January 2, 1930, and cashed the following day.

This question is controlled by the opinion of the Supreme Court in *Avery v. Commissioner*,—U. S. — (Apr. 30, 1934). In both that case and this it was the practice to mail out checks on the last day of the year so as to reach stockholders on the first business day of the following year. It does not appear that the petitioner could have obtained pay-

ment in 1929, and the practice of the corporation shows that it was not intended that stockholders should receive their dividends until the year following declaration. The case here is even stronger for the petitioner than was the Avery case, for here the resolution did not fix a date of payment, while in the Avery case the dividends were declared payable on or before December 31. We accordingly hold that the dividends here involved were not income to petitioners in 1929.

Decision will be entered under Rule 50. [14]

United States Board of Tax Appeals

Docket No. 64779

ALICE H. ELDRIDGE,

Petitioner,

vs.

COMMISSIONER OF INTERNAL REVENUE,

Respondent.

DECISION.

Pursuant to the opinion of the Board promulgated July 31, 1934, the respondent herein on September 5, 1934, having filed a motion for decision under Rule 50 and a proposed recomputation, and no opposition thereto being entered by the petitioner, it is

ORDERED and DECIDED that there is a deficiency in income tax for the year 1929 in the amount of \$70.

[Seal] (s) C. ROGERS ARUNDELL,
Member.

Entered: Sept. 28, 1934. [15]

In the United States Circuit Court of Appeals
for the Ninth Circuit

B. T. A. No. 64779

GUY T. HELVERING, Commissioner of Internal
Revenue,

Petitioner on Review,

vs.

ALICE H. ELDRIDGE,

Respondent on Review.

PETITION FOR REVIEW AND
ASSIGNMENTS OF ERROR.

To the Honorable Judges of the United States
Circuit Court of Appeals for the Ninth Circuit:

NOW comes Guy T. Helvering, Commissioner of Internal Revenue, by his attorneys, Frank J. Wideman, Assistant Attorney General, Robert H. Jackson, Assistant General Counsel for the Bureau of Internal Revenue, and Hartford Allen, Special Attorney for the Bureau of Internal Revenue, and respectfully shows:

I.

JURISDICTION.

The petitioner on review (hereinafter referred to as the Commissioner) is the duly appointed, qualified and acting Commissioner of Internal Revenue of the United States, holding his office by virtue of the laws of the United States.

The respondent on review, Alice H. Eldridge (hereinafter referred to as the taxpayer) is an individual residing at Seattle, Washington, and is an inhabitant of the judicial circuit of the United States Circuit Court of [16] Appeals for the Ninth Circuit. The said Alice H. Eldridge filed her income tax return for the calendar year 1929 with the Collector of Internal Revenue for the District of Washington, whose office is located at Seattle, Washington, and within the judicial circuit of the United States Circuit Court of Appeals for the Ninth Circuit.

The Commissioner files this petition pursuant to the provisions of Sections 1001, 1002 and 1003 of the Revenue Act of 1926, as amended by Section 603 of the Revenue Act of 1928, as amended by Section 1101 of the Revenue Act of 1932, as amended by Section 519 of the Revenue Act of 1934.

II.

PRIOR PROCEEDINGS.

On February 24, 1932, the Commissioner determined a deficiency in income tax against the taxpayer for the year 1929 in the amount of \$2,124.13 and sent by registered mail a notice of said defi-

ciency in accordance with the provisions of Section 272(a) of the Revenue Act of 1928. Thereafter, and on April 19, 1932, the taxpayer filed an appeal from the said determination with the United States Board of Tax Appeals, contesting the amount of the deficiency determined by the Commissioner as aforesaid. The Commissioner filed his answer to the said petition on May 18, 1932, denying the allegations of error contained in said petition. The case was tried before the United States Board of Tax Appeals on September 18, 1933.

On July 31, 1934 the Board promulgated its opinion and on September 28, 1934 entered its decision, wherein it was ordered and decided that there is a deficiency in income tax for the calendar year 1929 in the [17] amount of \$70.00. Two issues were decided by the Board, only one of which is presented for review.

III.

NATURE OF CONTROVERSY.

The taxpayer Alice H. Eldridge and her husband A. S. Eldridge are residents of the State of Washington. A. S. Eldridge keeps his books on a cash receipts and disbursements basis. All of the income in controversy and all the deductions claimed for the year 1929 involve community income or community property. During the year 1929, A. S. Eldridge was the president of the Eldridge Buick Company in which he was the sole stockholder. The Eldridge Buick Company was engaged in the business of selling automobiles.

During October, 1929, A. S. Eldridge bought 1000 shares of Carnation Milk Products Company no par value common stock for \$39,604.00 and 1000 shares of Fox Theatres Corporation Class A no par value common stock for \$28,500.00. The market value of the stock purchased declined shortly after purchases were made.

On December 30, 1929, A. S. Eldridge took the certificates for the Fox Theatres Corporation and the Carnation Company stock which he owned to the First Seattle Dexter Horton Securities Company with instructions to have the stock transferred to the name of the Eldridge Buick Company. This was done and upon Eldridge's personal account with the Eldridge Buick Company the bookkeeper, (who kept his books and also those of the company) under date of December 31, 1929, entered two credits, one for \$30,000.00, the market price on December 30, 1929, of 1000 shares of Carnation Milk Products Company stock at \$30.00 per share, and the other [18] for \$5,000.00, the market price on the same date of 1000 shares of Fox Theatres Corporation Class A stock at \$5.00 per share. No money passed in these transactions.

Shortly before the transactions above outlined A. S. Eldridge was indebted to the Eldridge Buick Company in the approximate amount of \$20,000.00. A. S. Eldridge also reduced his accrued salary due from the company by the amount of \$24,000.00 and the Eldridge Buick Company declared a dividend of \$50,000.00 payable to Eldridge, all of which transactions were recorded under date of December 31,

1929. The result of the adjustments made to the taxpayer's personal account with the company under date of December 31, 1929 was to show Eldridge with a closing credit balance of \$40,269.51 on his personal account with the company at that date.

The Commissioner determined that the transfer of record and re-registration of the Fox Theatres Corporation and Carnation Milk Products Company stock in the name of the Eldridge Buick Company did not constitute bona fide sales which created deductible losses in the determination of A. S. Eldridge and the taxpayer's net income for the calendar year 1929.

The taxpayer contended before the Board that the transactions constituted bona fide sales. The Board in its opinion promulgated July 31, 1934 sustained the contention of the taxpayer and held that the taxpayer was entitled to the deduction from gross income for the year 1929 in the amount of \$16,552.00 ($\frac{1}{2}$ of \$33,104.00) by reason of the transactions hereinbefore set forth.

IV.

ASSIGNMENTS OF ERROR.

The Commissioner avers that in the record and proceeding before [19] the Board of Tax Appeals and in the opinion and final decision rendered and entered by the Board of Tax Appeals manifest error occurred and intervened to the prejudice of the Commissioner who now assigns the following errors and each of them, which he avers occurred in the said record, proceeding, opinion and final

decision so rendered and entered by the Board of Tax Appeals:

1. The Board erred in holding that the taxpayer sustained losses upon the transfer of securities to the Eldridge Buick Company, a corporation owned and controlled by A. S. Eldridge.

2. The Board erred in holding that the said transfers created losses which were deductible from the gross income of the taxpayer for the year in controversy.

3. The Board erred in holding that the transfer of said securities constituted bona fide sales.

4. The Board erred in holding that the transactions between A. S. Eldridge and the Eldridge Buick Company in connection with the transfer of securities, actually constituted sales of such securities.

5. The Board erred in not holding that the purported sales were contrary to the intent of Congress and against public policy.

6. The Board erred in holding that the form of the transactions was controlling.

7. The Board erred in failing to recognize the substance of the transactions.

8. The Board erred in holding that the transactions should be recognized for income tax purposes.

9. The Board's findings of fact are not supported by the evidence. [20]

10. The Board's findings of fact are contrary to the evidence.

11. The Board erred in finding a deficiency due from the taxpayer in the amount of only \$70.00.

12. The Board erred in failing to find that there was a deficiency due from the taxpayer for the year in controversy in the amount of \$1,547.98.

WHEREFORE, the Commissioner petitions that the decision of the Board of Tax Appeals be reviewed by the United States Circuit Court of Appeals for the Ninth Circuit, that a transcript of the record be prepared in accordance with the law and with the rules of said Court for filing, and that appropriate action be taken to the end that the errors complained of may be reviewed and corrected by said Court.

(Sgd.) FRANK J. WIDEMAN,
Assistant Attorney General.

(Sgd.) ROBERT H. JACKSON,
Assistant General Counsel
for the
Bureau of Internal Revenue.

Of Counsel:

HARTFORD ALLEN,
Special Attorney,
Bureau of Internal Revenue. [21]

United States of America,
District of Columbia.—ss.

HARTFORD ALLEN, being duly sworn, says that he is a Special Attorney in the Bureau of Internal Revenue and as such is duly authorized to verify the foregoing petition for review; that he has read said petition and is familiar with the contents thereof; that said petition is true of his own

knowledge except as to the matters therein alleged on information and belief, and as to those matters he believes it to be true.

HARTFORD ALLEN

Sworn and subscribed to before me this 14 day of December, 1934.

(Sgd.) GEORGE W. KREIS,

Notary Public.

My Commission expires Nov. 16, 1937.

[Endorsed]: U. S. Board of Tax Appeals. Filed Dec. 14, 1934. [22]

[Title of Court and Cause.]

NOTICE OF FILING PETITION
FOR REVIEW.

To: Mrs. Alice H. Eldridge,
802 East Pike Street,
Seattle, Washington.
Thomas N. Fowler, Esq.,
923 Insurance Building,
Seattle, Washington.

You are hereby notified that the Commissioner of Internal Revenue did, on the 14th day of December, 1934, file with the Clerk of the United States Board of Tax Appeals, at Washington, D. C., a petition for review by the United States Circuit Court of Appeals for the Ninth Circuit, of the deci-

sion of the Board heretofore rendered in the above-entitled case. A copy of the petition for review and the assignments of error as filed is hereto attached and served upon you.

Dated this 14th day of December, 1934.

(Sgd.) ROBERT H. JACKSON,
Assistant General Counsel
for the
Bureau of Internal Revenue.

Personal service of the above and foregoing notice, together with a copy of the petition for review and assignments of error mentioned therein, is hereby acknowledged this 20th day of December, 1934.

Respondent on Review.

(Sgd.) THOMAS N. FOWLER,
Attorney for Respondent on Review.

Dec. 20, 1934. [23]

State of Washington,
County of King.—ss.

DON F. KING, of full age, being first duly sworn, deposes and says: that he is an Internal Revenue Agent for the District of Washington; that on the 20th day of December, 1934, he served the hereto attached notice of filing petition for review and assignments of error upon Mrs. Alice H. Eldridge, the respondent on review, by exhibiting the original to and leaving a copy thereof with said Alice H. Eldridge, at her usual place of abode, 3115

West Laurelhurst Drive, Seattle, Washington, at 12 o'clock p. m. of said day.

(s) DON F. KING

Subscribed and sworn to before me this 20th day of December, 1934.

[Seal] (s) BERNARD A. STOCKING,
Notary Public residing at Seattle, Washington.
Notary Public in and for the State of Washington
residing at Seattle.

My Commission expires June 18th, 1936.

[Endorsed]: Filed Dec. 27, 1934. [24]

[Title of Court and Cause.]

STIPULATION.

It is hereby stipulated by and between the parties of this proceeding through their respective counsel:

1. That the statement of evidence set forth in the case of Commissioner of Internal Revenue v. A. S. Eldridge, (B. T. A. Docket No. 64778), now pending before the United States Circuit Court of Appeals for the Ninth Circuit applies equally to the instant proceeding, the cases having been consolidated for hearing before the Board.

2. That the aforesaid statement of evidence may be deemed to be incorporated in the transcript of record in the case of Alice H. Eldridge and the printing of the record in the case of Alice H. Eld-

sion of the Board heretofore rendered in the above-entitled case. A copy of the petition for review and the assignments of error as filed is hereto attached and served upon you.

Dated this 14th day of December, 1934.

(Sgd.) ROBERT H. JACKSON,
Assistant General Counsel
for the
Bureau of Internal Revenue.

Personal service of the above and foregoing notice, together with a copy of the petition for review and assignments of error mentioned therein, is hereby acknowledged this 20th day of December, 1934.

.....
Respondent on Review.

(Sgd.) THOMAS N. FOWLER,
Attorney for Respondent on Review.

Dec. 20, 1934. [23]

State of Washington,
County of King.—ss.

DON F. KING, of full age, being first duly sworn, deposes and says: that he is an Internal Revenue Agent for the District of Washington; that on the 20th day of December, 1934, he served the hereto attached notice of filing petition for review and assignments of error upon Mrs. Alice H. Eldridge, the respondent on review, by exhibiting the original to and leaving a copy thereof with said Alice H. Eldridge, at her usual place of abode, 3115

West Laurelhurst Drive, Seattle, Washington, at 12 o'clock p. m. of said day.

(s) DON F. KING

Subscribed and sworn to before me this 20th day of December, 1934.

[Seal] (s) BERNARD A. STOCKING,
Notary Public residing at Seattle, Washington.
Notary Public in and for the State of Washington
residing at Seattle.

My Commission expires June 18th, 1936.

[Endorsed]: Filed Dec. 27, 1934. [24]

[Title of Court and Cause.]

STIPULATION.

It is hereby stipulated by and between the parties of this proceeding through their respective counsel:

1. That the statement of evidence set forth in the case of Commissioner of Internal Revenue v. A. S. Eldridge, (B. T. A. Docket No. 64778), now pending before the United States Circuit Court of Appeals for the Ninth Circuit applies equally to the instant proceeding, the cases having been consolidated for hearing before the Board.

2. That the aforesaid statement of evidence may be deemed to be incorporated in the transcript of record in the case of Alice H. Eldridge and the printing of the record in the case of Alice H. Eld-

ridge be dispensed with as unnecessary, since the record to be printed in the case of A. S. Eldridge is in all respects similar.

3. That the decision in the case of Alice H. Eldridge shall abide and be governed by the decision and proceedings in the case of A. S. Eldridge.

THOMAS N. FOWLER,

Attorney for Respondent on Review.

(Signed) ROBERT H. JACKSON,

Attorney for Petitioner on Review.

mms - 2/5-35

[25]

[Title of Court and Cause.]

PRAECIPE FOR RECORD.

To the Clerk of the United States Board of Tax Appeals:

You will please prepare, transmit and deliver to the Clerk of the United States Circuit Court of Appeals for the Ninth Circuit, copies duly certified as correct of the following documents and records in the above-entitled cause in connection with the petition for review by the said Circuit Court of Appeals for the Ninth Circuit, heretofore filed by the Commissioner of Internal Revenue:

1. Docket entries of proceedings before the Board.
2. Pleadings before the Board:
 - (a) Petition, including copy of deficiency notice.
 - (b) Answer.
3. Findings of fact and opinion of Board.
4. Decision of Board.

5. Petition for review, notice of filing thereof, and proof of service.

6. Stipulation as to incorporation of statement of evidence by reference, and omission of printing thereof from the record in this proceeding.

7. This praecipe.

(Signed) ROBERT H. JACKSON,
Assistant General Counsel
for the
Bureau of Internal Revenue.

Service of a copy of the within praecipe is hereby admitted this 18 day of February, 1935.

THOMAS N. FOWLER,
Attorney for Respondent on Review.

[Endorsed]: Filed Feb. 27, 1935. [26]

[Title of Court and Cause.]

CERTIFICATE.

I, B. D. Gamble, clerk of the U. S. Board of Tax Appeals, do hereby certify that the foregoing pages, 1 to 26, inclusive, contain and are a true copy of the transcript of record, papers, and proceedings on file and of record in my office as called for by the Praecipe in the appeal (or appeals) as above numbered and entitled.

In testimony whereof, I hereunto set my hand and affix the seal of the United States Board of Tax Appeals, at Washington, in the District of Columbia, this 25th day of March, 1935.

[Seal]

B. D. GAMBLE,
Clerk,

United States Board of Tax Appeals.

[Endorsed]: No. 7819. United States Circuit Court of Appeals for the Ninth Circuit. Commissioner of Internal Revenue, Petitioner, vs. Mrs. Alice H. Eldridge, Respondent. Transcript of the Record. Upon Petition to Review an Order of the United States Board of Tax Appeals.

Filed April 1, 1935.

PAUL P. O'BRIEN,

Clerk of the United States Circuit Court of Appeals
for the Ninth Circuit.

15
No. 7819

**In the United States Circuit Court of
Appeals for the Ninth Circuit**

COMMISSIONER OF INTERNAL REVENUE, PETITIONER

v.

MRS. ALICE H. ELDRIDGE, RESPONDENT

ON PETITION FOR REVIEW OF DECISION OF THE UNITED
STATES BOARD OF TAX APPEALS

BRIEF FOR THE PETITIONER

FRANK J. WIDEMAN,
Assistant Attorney General.

SEWALL KEY,
LUCIUS A. BUCK,
Special Assistants to the Attorney General.

FILED

AUG 19 1935

PAUL P. O'BRIEN,



**In the United States Circuit Court of
Appeals for the Ninth Circuit**

No. 7819

COMMISSIONER OF INTERNAL REVENUE, PETITIONER
v.
MRS. ALICE H. ELDRIDGE, RESPONDENT

*ON PETITION FOR REVIEW OF DECISION OF THE UNITED
STATES BOARD OF TAX APPEALS*

BRIEF FOR THE PETITIONER

OPINION BELOW

The only previous opinion in this case is that of the United States Board of Tax Appeals (R. 12-21) which is reported in 30 B. T. A. 1322.

JURISDICTION

The case involves a deficiency in income tax for the calendar year 1929 (R. 4). The Commissioner of Internal Revenue determined a deficiency in the amount of \$2,124.13 (R. 7). The Board redetermined the deficiency in the amount of \$70 (R. 22). This appeal is taken from a decision of the Board of Tax Appeals promulgated September

28, 1934 (R. 22), and is brought to this Court by a petition for review filed December 4, 1934 (R. 22-29), pursuant to the provisions of the Revenue Act of 1926, Sections 1001-1003, c. 27, 44 Stat. 9, 109-110, as amended by the Revenue Act of 1932; Section 1101, c. 209, 47 Stat. 169.

QUESTION PRESENTED

The taxpayer's husband owned and controlled corporation B but by reason of the community property laws of the State of Washington the taxpayer was interested therein to the extent of one-half of the capital stock of corporation B. At the end of the tax year, for the purpose of establishing a deductible loss, taxpayer's husband transferred certain stock (owned by the marital community) to corporation B. The only consideration for the transfer was a credit in the amount of the market value of the stock on the books of B, the credit being made to taxpayer's husband. Corporation B was the agency or instrumentality through which the taxpayer's husband handled his personal account. Was the transfer sufficient to justify the claimed deduction from gross income under Section 23 (e) (2) of the Revenue Act of 1926?

STATUTES AND REGULATIONS INVOLVED

The statutes and regulations involved are set forth in the Appendix of the brief in the case of *Commissioner v. A. S. Eldridge*, Case No. 7818, now pending in this Court.

SPECIFICATION OF ERRORS TO BE URGED

The Board of Tax Appeals erred in not finding and holding that the transfer of the corporate stock by the taxpayer's husband to his corporation was insufficient to justify the deduction of the amount of the claimed loss from the taxpayer's gross income for the calendar year 1929. In connection with and as a part of this specification of errors, the assignments of error contained in the petition for review (R. 26-28) are hereby included herein as fully and completely as if again set forth at this point *in haec verba*.

STATEMENT AND ARGUMENT

This case and the case of A. S. Eldridge, above referred to, were heard together by the Board of Tax Appeals. The findings of fact cover both cases (R. 13-17). The statement of evidence set forth in the record in the A. S. Eldridge case applies equally to this case (R. 31). The parties hereto have stipulated that that statement of evidence may be deemed to be incorporated in the record in this case (R. 31-32).

The parties hereto have stipulated that the decision in this case "shall abide and be governed by the decision and proceedings in the case of A. S. Eldridge" (R. 32). The husband, of course, under the community property laws of the State of Washington was acting for the community in the transaction and was representing and binding his wife's interests equally with his own, and the de-

fects in the transaction apply equally to the taxpayer in this case. This conclusion is equally true on plain principles of agency unaffected by community property laws. Thus, in the case of *Slayton v. Commissioner*, 76 F. (2d) 497 (C. C. A. 1st), the court said (p. 499):

Mrs. Slayton knew little about the business of the Hoyt Shoe Company except as she was told by her husband. Her transfer of the stock was at his suggestion and from her testimony he clearly acted as her agent in arranging for the transfer of the shares.

In view of the stipulation and in view of the above principles we deem further discussion of the legal principles involved in this case to be unnecessary. We respectfully submit this case on the argument contained in the brief in the A. S. Eldridge case and to abide by the results in that case in accordance with the stipulation herein.

Respectfully submitted.

FRANK J. WIDEMAN,
Assistant Attorney General.

SEWALL KEY,

LUCIUS A. BUCK,

Special Assistants to the Attorney General.

AUGUST 1935.

IN THE
UNITED STATES CIRCUIT
COURT OF APPEALS
FOR THE NINTH CIRCUIT

No. 7819

COMMISSIONER OF INTERNAL REVENUE,
Petitioner,

v.

ALICE H. ELDRIDGE,
Respondent.

On Petition for Review of Decision of the United States
Board of Tax Appeals

BRIEF FOR THE RESPONDENT

THOMAS N. FOWLER,
Attorney for Respondent.

FILED

SEP 7 - 1935

PAUL P. HEN

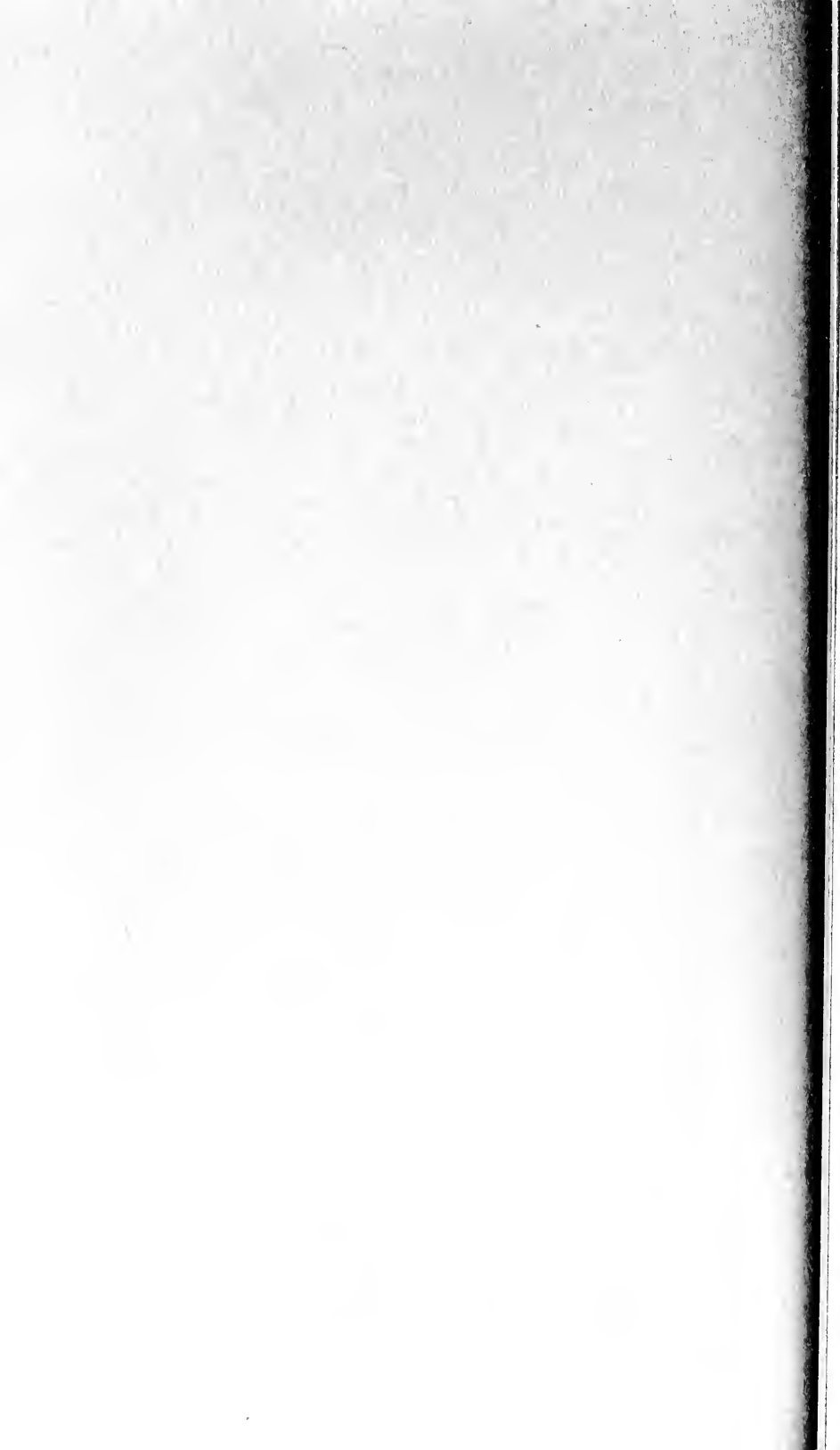

IN THE
UNITED STATES CIRCUIT
COURT OF APPEALS
FOR THE NINTH CIRCUIT

No. 7819

COMMISSIONER OF INTERNAL REVENUE,

Petitioner,

v.

ALICE H. ELDRIDGE,

Respondent.

On Petition for Review of Decision of the United States
Board of Tax Appeals

BRIEF FOR THE RESPONDENT

QUESTION PRESENTED

Taxpayer's husband in December, 1929 owned certain stock the value of which had very materially declined during the period of his ownership. It is admitted that all of the said property was the community property of the taxpayer's husband, A. S. Eldridge and taxpayer. In December, 1929, taxpayer's husband intended to sell the securities for the purpose of establishing a deductible loss and further intended to advance the proceeds of the sale to the Eldridge Buick Co, a corporation. The Eldridge Buick Co was solely owned by the said A. S. Eldridge (taxpayer's husband) except for qualifying shares held by members of his family. It had been the custom of A. S. Eldridge for many years to have the Eldridge Buick Co indebted to him. At the close of 1929 it was found that the Eldridge Buick Co. had had substantial losses during that year and that taxpayer was indebted to Eldridge Buick Co instead of having the corporation indebted to him. Eldridge desired to reverse that condition and decided to sell the securities upon the open market and advance the proceeds to the Eldridge Buick Co. The sale of the securities was made by Eldridge direct to the corporation at the then market value for the purpose of assisting the corporation to

reflect a credit balance in Eldridge's personal account and for the further purpose of establishing a deductible loss. The certificates of stock were delivered and transferred to the name of the Eldridge Buick Co and have ever since remained in the possession and control of the corporation. The consideration was paid by the corporation by crediting Eldridge's personal account.

Was the sale by Eldridge to the solely owned and controlled corporation sufficient to justify the claimed deduction from gross income under Section 23 (e) (2) of the Revenue Act of 1928?

STATEMENT AND ARGUMENT

This case and the case of A. S. Eldridge above referred to (United States Circuit Court of Appeals for the Ninth Circuit, No. 7818) were heard together by the Board of Tax Appeals. The Findings of Fact and the Opinion of the court cover both cases (R 13-20). The Statement of Evidence set forth in the record in the A. S. Eldridge case applies equally to this case (R 31). The parties heretofore have stipulated that that statement of evidence may be deemed to be incorporated in the record in this case (R 31, 32).

The parties heretofore have stipulated in this case "That they shall abide and be governed by the decision and proceedings in the case of A. S. Eldridge." (R 32).

Reference is hereby made to all of the arguments and authorities set forth in detail in the case of A. S. Eldridge and the same is made a part hereof as if incorporated herein in full.

We deem further discussion of the legal principles involved in this case to be unnecessary. We respectfully submit this case on the argument contained in the brief in the A. S. Eldridge case and agree to abide by the results in that case in accordance with the stipulation herein.

Respectfully submitted,

THOMAS N. FOWLER,

Attorney for Respondent. 24

(25)

